

EISENBLÄTTER

Simply better ideas.

**SURFACE TECHNOLOGIES
FOR SPECIALISTS**

EISENBLÄTTER

EISENBLÄTTER

EISENBLÄTTER

EISENBLÄTTER

EISENBLÄTTER

EISENBLÄTTER

EISENBLÄTTER

EISENBLÄTTER

EISENBLÄTTER

EISENBLÄTTER

EISENBLÄTTER

EISENBLÄTTER

EISENBLÄTTER

EISENBLÄTTER

EISENBLÄTTER

EISENBLÄTTER

EISENBLÄTTER

EISENBLÄTTER

EISENBLÄTTER

EISENBLÄTTER

EISENBLÄTTER

EISENBLÄTTER

EISENBLÄTTER

EISENBLÄTTER

EISENBLÄTTER

EISENBLÄTTER

EISENBLÄTTER

EISENBLÄTTER

EISENBLÄTTER

EISENBLÄTTER

EISENBLÄTTER

EISENBLÄTTER

EISENBLÄTTER

EISENBLÄTTER

EISENBLÄTTER

EISENBLÄTTER

EISENBLÄTTER

EISENBLÄTTER

EISENBLÄTTER

EISENBLÄTTER

EISENBLÄTTER

EISENBLÄTTER

EISENBLÄTTER

EISENBLÄTTER

EISENBLÄTTER

EISENBLÄTTER

EISENBLÄTTER

EISENBLÄTTER

EISENBLÄTTER

EISENBLÄTTER

EISENBLÄTTER

EISENBLÄTTER

EISENBLÄTTER

EISENBLÄTTER

EISENBLÄTTER

EISENBLÄTTER

EISENBLÄTTER

EISENBLÄTTER

EISENBLÄTTER

EISENBLÄTTER

EISENBLÄTTER

EISENBLÄTTER

EISENBLÄTTER

EISENBLÄTTER

EISENBLÄTTER

EISENBLÄTTER

EISENBLÄTTER

EISENBLÄTTER

EISENBLÄTTER

EISENBLÄTTER

EISENBLÄTTER

EISENBLÄTTER

EISENBLÄTTER

EISENBLÄTTER

EISENBLÄTTER

EISENBLÄTTER

EISENBLÄTTER

EISENBLÄTTER

EISENBLÄTTER

EISENBLÄTTER

EISENBLÄTTER

EISENBLÄTTER

EISENBLÄTTER

EISENBLÄTTER

EISENBLÄTTER

EISENBLÄTTER

EISENBLÄTTER

EISENBLÄTTER

EISENBLÄTTER

EISENBLÄTTER

EISENBLÄTTER

EISENBLÄTTER

EISENBLÄTTER

EISENBLÄTTER

EISENBLÄTTER

EISENBLÄTTER

EISENBLÄTTER

EISENBLÄTTER

EISENBLÄTTER

EISENBLÄTTER

EISENBLÄTTER

EISENBLÄTTER

EISENBLÄTTER

EISENBLÄTTER

EISENBLÄTTER

EISENBLÄTTER

EISENBLÄTTER

EISENBLÄTTER

EISENBLÄTTER

EISENBLÄTTER

EISENBLÄTTER

EISENBLÄTTER

EISENBLÄTTER

EISENBLÄTTER

EISENBLÄTTER

EISENBLÄTTER

EISENBLÄTTER

EISENBLÄTTER



Our Best Ideas For Your



Metal



EISENBLÄTTER

Simply better ideas.

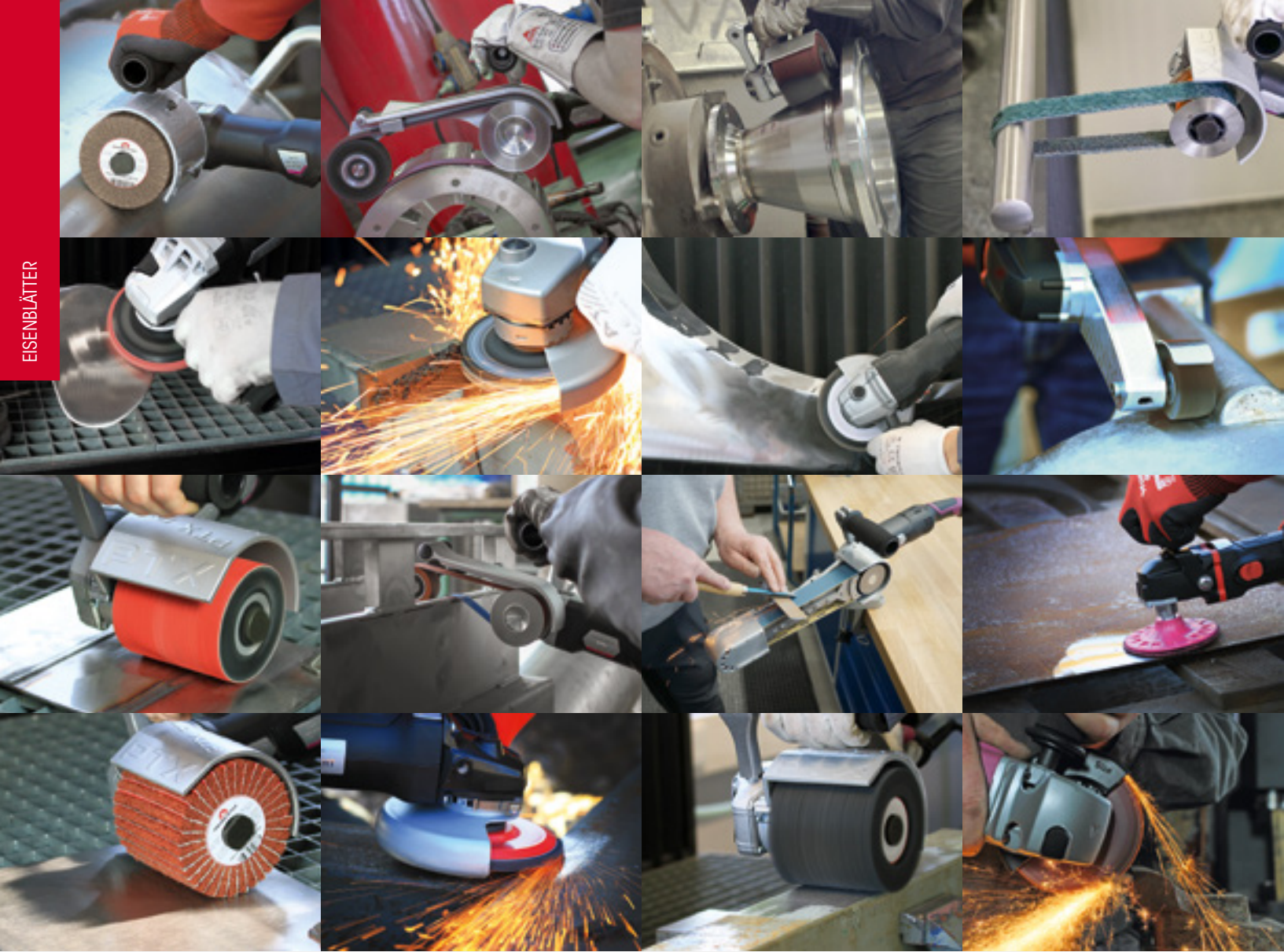

HOW TO CONTACT US

Main office telephone numbers:

Main office	(+49) 8171 9082 – 010
Sales	(+49) 8171 9082 – 020
Purchasing	(+49) 8171 9082 – 050
Accounts	(+49) 8171 9082 – 060

Main office fax numbers:

Main office	(+49) 8171 9082 – 210
Sales	(+49) 8171 9082 – 220
Purchasing	(+49) 8171 9082 – 250
Accounts	(+49) 8171 9082 – 260

Main office address

Office and administration:
 Gerd Eisenblätter GmbH
 Jeschkenstraße 12d
 82538 Geretsried, Germany

Main office address

Delivery:
 Gerd Eisenblätter GmbH
 Keplerweg 4
 82538 Geretsried, Germany

Eisenblätter online:

info@eisenblaetter.de
 eisenblaetter.de
 eisenblatter.com

Eisenblätter Demo Center

Koblenzer Str. 29a
 56656 Brohl-Lützing, Germany
 Phone (+49) 2633 2000 982
 Fax (+49) 2633 2000 983
 demo@eisenblaetter.de



Dear customers and those interested in our products,

After moving operations to our new, highly modern company building in 2015, EISENBLÄTTER grew quickly, setting new standards for the development of new, even more powerful grinding machines and tools for metal surface technology.

More powerful abrasives of necessity require more powerful drive motors if they are to stand up to the mechanical and thermal loads in the long run. We have developed completely new machines of this type with unprecedented performance characteristics and torques.

In the interest of cordless freedom, battery-powered versions of nearly all new grinding machines have been developed using the revolutionary CAS system. CAS provides many manufacturers with cross-industry compatibility for the first time. This allows significant savings on a wide variety of battery-powered systems in the long term. All battery-powered devices have been developed for professional use and are scarcely less powerful or manageable than plug-in machines.

But most of the grinding systems have also been significantly improved, refined, and their performances optimised for our customers. Many articles have also been equipped with environmentally and user-friendly natural fibre components, and today, EISENBLÄTTER is the global leader in this forward-looking technology.

For our other core competence, manufacturing unique flap discs, we are introducing new, greatly improved products. Many articles have once again been raised to an entirely new level of performance.

The EISENBLÄTTER TEAM plans to continue to introduce especially economical, revolutionary, and environmentally friendly surface systems, all of them **made in Germany**.

Gerd Eisenblätter
David Eisenblätter

Certified quality!

DIN ISO certification according to the latest standards

Eisenblätter GmbH – inventor and innovation driver behind much of today's familiar grinding technology – was certified according to the latest standard, DIN ISO 9001:2015, in 2018.

This certification in quality management guarantees our customers verifiable, consistent, high quality for our high-tech products, which are manufactured in Germany.

Product safety and environmental and user-friendliness have been the most important considerations at EISENBLÄTTER for decades!



**Buy them now online!
Test the Eisenblätter
online shop!**

All information about our products, new items, and additional user videos can be found at www.eisenblaetter.de.



Natural fibre

Backing plate consists primarily of regenerative natural fibres



Flexible

Flexible material



Flexible

Flexible backing material



Copyrighted design

Design or product feature is under copyright



Patented

Patented



Patent pending

Patent pending



Approved for

Suitable for cutting



5° angle of incidence

Tool support at a 5° angle



Approved for

Suitable for rough and side grinding



Free of fibre glass

Free of fibre glass components



M14 integrated

Integrated M14 threads



Plus backing pad

To be used only with a suitable backing pad



Reduced noise

Noise level reduced under load



Flat contact surface area

Flat tool support



Trimable

Trimable tool backing plate



Balanced

Unique wheel balancing to ensure that the wheel runs perfectly



Accessories

Accessory items



Material: All metals

To be used on all metals



Material: Aluminium

To be used on aluminium



Material: Non-ferrous metals

To be used on non-ferrous metals



Material: Stainless steel

To be used on stainless steel



Material: Wood

To be used on wood



Material: Steel

To be used on steel



Material: Hard plastics

To be used on hard plastics



HighTorque

New motor with extremely high torque



Suitable for ceramic flap discs



MPA tested

Tested by the Material Prüfanstalt testing authority

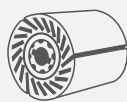

Expansion roller

Only to be used with a POLY-PTX® expansion roller

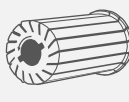

Eco Smart adapter

Only to be used with the POLY-PTX® Eco Smart adapter



Guaranteed free of rust

Registered trademark of Focus Rostfrei



NEW FROM EISENBLÄTTER

New plug-in machines
New battery-powered machines
Products with natural fibre backing plates

012



ANGULAR GRINDING – CIRCULAR GRINDING

Power tools
Cutting and rough grinding
Grinding and blending
Finishing and fine grinding
Polishing | Cleaning

018



MULTIFUNCTIONAL GRINDING

Power tools | Grinding and blending
Finishing and fine grinding | Polishing | Cleaning
Technical brushes | MINI FIX HOOK & LOOP system
Stationary machines | FIX HOOK & LOOP complete system
PINLOC | Flexible shafts

108



LINEAR GRINDING – SATIN FINISHING

Power tools
Grinding and blending
Finishing and fine grinding | Polishing
Cleaning | Technical brushes
Pipe machining with POLY-PTX®

154



BELT GRINDING

Application overview
Power tools
Grinding and blending
Finishing and fine grinding
Polishing

210



DEBURRING AND BEVELLING

Power tools
Stationary machines

256



CHEMICALS AND CARE PRODUCTS

Cleaning
Protection
Preserving
Grinding additives
Test sets

274



ACCESSORIES

Product case
Stainless steel cover plate
Work safety
Ball joint mount

282

THE NEXT GENERATION

THE NEW PLUG-IN MACHINES

NEW



VARILEX® 1802 HT

22

NEW



VARILEX® POLISHER HT

78

NEW



MINI MAX® PRO 1000

112

NEW



VARILEX® 1000

136

NEW



POLY-PTX® 802 HT

158

NEW



PIPE MAX 802 HT

214

Newly developed drive motors for much more performance

A refined motor with very high power density and a number of new features ensures completely new standards of torque, productivity, and service life.



HT HighTorque **CERAMIC READY**

Power transmission with a planetary gear

A high-quality planetary gear has been designed for grinding machines in the low speed range (such as POLY-PTX®, POLISHER, PIPE MAX etc.). It ensures wear-resistant power transmission with enormous additional torque.



Perfect high-tech: the new Eisenblätter machines win over users with increased power and longer service life – all because of the high-quality workmanship, innovative, patented technology, and familiar Eisenblätter quality characteristics in the areas of ergonomics and operability.

NEW**PIPE SNIPER 802 HT****218****NEW****GLADIUS® 1802 HT****222****NEW****PIPE MAX HT MINI****232****NEW****BAND-IT****244**

DUST PREVENT SYSTEM – effective protection for the interior of the motor

The new DUST PREVENT SYSTEM (patent pending) effectively provides protection from coarse swarf and metal particles without impairing the cooling ventilation. A protective cap effectively reduces dust entering the lateral ventilation grilles. Particles bounce off the protective cap. Fresh air intake is only from the air in the rear, which is largely free of particles.

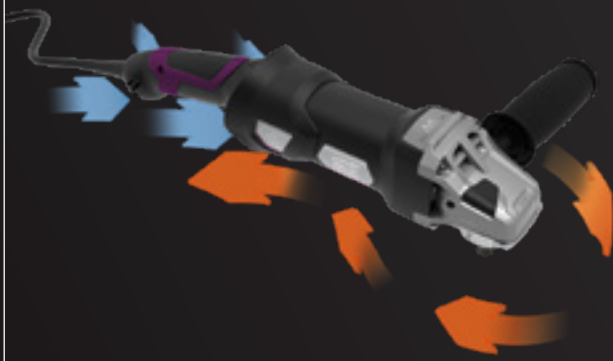

CORDLESS FREEDOM

THE NEW BATTERY-POWERED MACHINES

NEW



VARILEX® AKKU PRO HT

26

NEW



VARILEX® POLISHER AKKU

82

NEW



MINI MAX® AKKU

114

NEW



POLY-PTX® AKKU HT

162

NEW



PIPE MAX AKKU

236

NEW



BAND-IT AKKU

244

100% leading battery-powered technology

LiHD – the highest-performance battery technology in the world covers power ranges from 400 to 3,200, providing sufficient power for even energy-intensive applications.



LiHD
TECHNOLOGY

Power transmission with a planetary gear

A high-quality planetary gear has been designed for grinding machines in the low speed range (such as POLY-PTX®, POLISHER, PIPE MAX etc.). It ensures wear-resistant power transmission with enormous additional torque.



Cordless Alliance System (CAS):

One battery for everything.



Find out more: www.cordless-alliance-system.de

Discover cordless freedom! Take advantage of 100% compatibility of machines, battery packs, and chargers in a cross-manufacturer system! **CAS makes the most powerful battery system in the industry from Metabo and more than 30 years of battery competence available for Eisenblätter machines as well.**

What's in it for you? Highest levels of reliability, clear cost benefits, and great investment security.

Cordless Alliance System (CAS) is an association of leading power tool brands. This makes a number of professional applications from a wide variety of machine manufacturers available with the same battery system for the first time – from standard to special jobs.

More power

with the new LiHD cell technology in conjunction with a newly developed battery pack

- Larger contacts and busbars capable of carrying high currents
- A cell connector made of a special copper delivers three times the conductivity

More charge

- More active material in the cell
- High-quality materials (silver and copper) used

More service life

and extreme robustness:

- Complete compound and protective lacquer on the electronics and optimum seal in the cover design ensure deal protection from internal contamination
- Rubber puffer protects the cells
- More usable energy means charging less often
- Exterior rubber battery pack coating ensures safe, non-slip positioning and serves as impact protection

NATURAL FIBRE INSTEAD OF FIBRE GLASS

FIND OUT MORE ON PAGE 42



ENVIRONMENTALLY FRIENDLY

NO FIBRE GLASS DUST

FANTASTIC PRICE AND PERFORMANCE

100% SELF-TRIMMING

THE LATEST HIGH-TECH DISCS WITH

NATURAL FIBRE COMPOUND BACKING PLATES



TRIMFIX® HellFire®
for all metals

Grinding and blending p. 44

NEW



TRIMFIX® SteelFire®
for steel

Grinding and blending p. 46

NEW



Heavy-duty flap discs
for all metals or for steel

Grinding and blending p. 50/52



TRIMFIX® BLACK MAMBA®
For steel · Stainless steel

Grinding and blending p. 54



TRIMFIX® ZIRCOPUR®
For steel · Stainless steel

Grinding and blending p. 56



PLANTEX® Cool Top® Universal
For steel · Stainless steel · Non-ferrous
metals · Hard plastics

Grinding and blending p. 58

NEW



MAGNUM® DecoFinish
for all metals · Wood · Hard plastics

Finishing and fine grinding p. 88

NEW



TRIMFIX® Fleece Flap
For all metals · Wood

Finishing and fine grinding p. 90

NEW

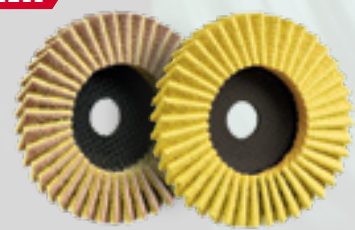

**BRIGHTEX® FLAP
BERRY & SUN**
for all metals

Polishing p. 96/97

NEW



MAGNUM® CLEAN-MIX
For all metals · Wood · Brick

Cleaning p. 102

NEW



MAGNUM® CLEAN-PLUS
For all metals · Wood

Cleaning p. 103

NEW



MAGNUM® CLEAN Strong
For all metals · Wood

Cleaning p. 104

**Don't settle
for anything
less than
the best**



ANGULAR GRINDING – CIRCULAR GRINDING

SECTION HIGHLIGHTS	20	FINISHING AND FINE GRINDING	78
POWER TOOLS	22	NEW VARILEX® POLISHER HT	78
NEW VARILEX® 1802 HT	22	NEW VARILEX® POLISHER AKKU	82
NEW VARILEX® AKKU PRO HT	26	NEW VARILEX® POLISHER AKKU accessories	84
NEW VARILEX® AKKU PRO HT accessories	28	NEW VARILEX® POLISHER accessory set	86
NEW VARILEX® accessories	29	MAGNUM® Poly Magic Wheel	87
NEW VARILEX® accessory sets	32	NEW MAGNUM® DecoFinish	88
VARILEX® WSF 1800	34	TRIMFIX® Fleece Flap	90
VARILEX® WSF 1800 accessories	36	NEW TRIMFIX® Fleece Flap Soft	91
CUTTING AND ROUGH GRINDING	38	MAGNUM® Fleece Top	92
MAGNUM® RAZORCUT® cutting disc	38	NEW MAGNUM® Top Mix/Top Mix Strong	94
MAGNUM® FINECUT cutting disc	39	POLISHING	96
MAGNUM® TWINFLEX® cutting and rough grinding disc	39	NEW BRIGHTEX® FLAP BERRY (pre-polishing)	96
MAGNUM® FLEXO rough grinding disc	40	NEW BRIGHTEX® FLAP SUN (main polish)	97
GRINDING AND BLENDING	41	BRIGHTEX® high-performance polishing pastes	98
Flap discs	41	BRIGHTEX® Softclean Powder	99
Natural fibre backing plate	42	BRIGHTEX® microfibre cloths	99
TRIMFIX® HellFire® ceramic hybrid flap disc	44	NEW Power Cleaner	100
NEW TRIMFIX® SteelFire® flap disc	46	Polishing pastes (Classic)	100
Power grinding 48		Pink polishing cream	100
NEW TRIMFIX® HellFire® heavy-duty flap disc 50		CLEANING	102
NEW TRIMFIX® SteelFire® heavy-duty flap disc	52	NEW MAGNUM® CLEAN-MIX	102
TRIMFIX® BLACK MAMBA® flap disc	54	NEW MAGNUM® CLEAN-PLUS	103
TRIMFIX® ZIRCOPUR® flap disc	56	NEW MAGNUM® CLEAN Strong	104
PLANTEX® Cool Top® Universal flap disc	58	NEW MAGNUM® STAINLESS-CLEAN	105
MAGNUM® Cool Top® 5+ flap disc	60	CLEAN disc MCD	106
MAGNUM® Fillet Weld flap disc	62		
MAGNUM® Ceramic flap disc	64		
BLUE SHARK® Elastic flap disc	66		
TIGER SHARK® Elastic flap disc	68		
ZIRCOTEX® Nylon Flat flap disc	70		
NEW Test the best in the box	71		
Improve performance with			
Eisenblätter products	72		
Fibre discs	76		
COLDSTEEL® Ceramic fibre disc	76		
COLDSTEEL® backing pad	77		

POWER TOOLS



VARILEX® 1802 HT p. 22

VARILEX® POLISHER HT p. 78

VARILEX® AKKU PRO HT p. 26

22

CUTTING & ROUGH GRINDING



MAGNUM® RAZORCUT®
Cutting disc p. 38

MAGNUM® TWINFLEX®
Combination disc p. 39

38

FLAP DISCS



41

NATURAL FIBRE FLAP DISCS



42

GRINDING AND BLENDING

MAGNUM® Cool Top® 5+ p. 60

TIGER SHARK® Elastic p. 68

COLDSTEEL® Ceramic fibre disc p. 76



BLUE SHARK® Elastic p. 66



43

FINISHING & FINE GRINDING



MAGNUM® DecoFinish p. 88

78

POLISHING



BRIGHTEX® FLAP BERRY & SUN p. 96/97

96

CLEANING

MAGNUM® CLEAN-PLUS p. 103

MAGNUM® STAINLESS-CLEAN p. 105



MAGNUM® CLEAN-MIX p. 102

MAGNUM® CLEAN Strong p. 104

102

VARILEX® 1802 HT **NEW**

THE TORQUE MARVEL

Since the “ceramic age” of flap discs, and indeed of fibre, cutting, and rough grinding discs, the performance demands on hand-held electrical devices (angle grinders, etc.) have grown enormously. Most devices can’t stand up to this added friction and contact pressure over the long haul. Grinders overheat quickly, switch off automatically, or the rotor and field coil burn through in no time. Eisenblätter has met this challenge by refining its ceramic flap discs and variable-speed angle grinder under the VARILEX® brand. Effective immediately, the new VARILEX® 1802 HT (high torque) meets all performance demands of cutting-edge ceramic grinding discs of all kinds.

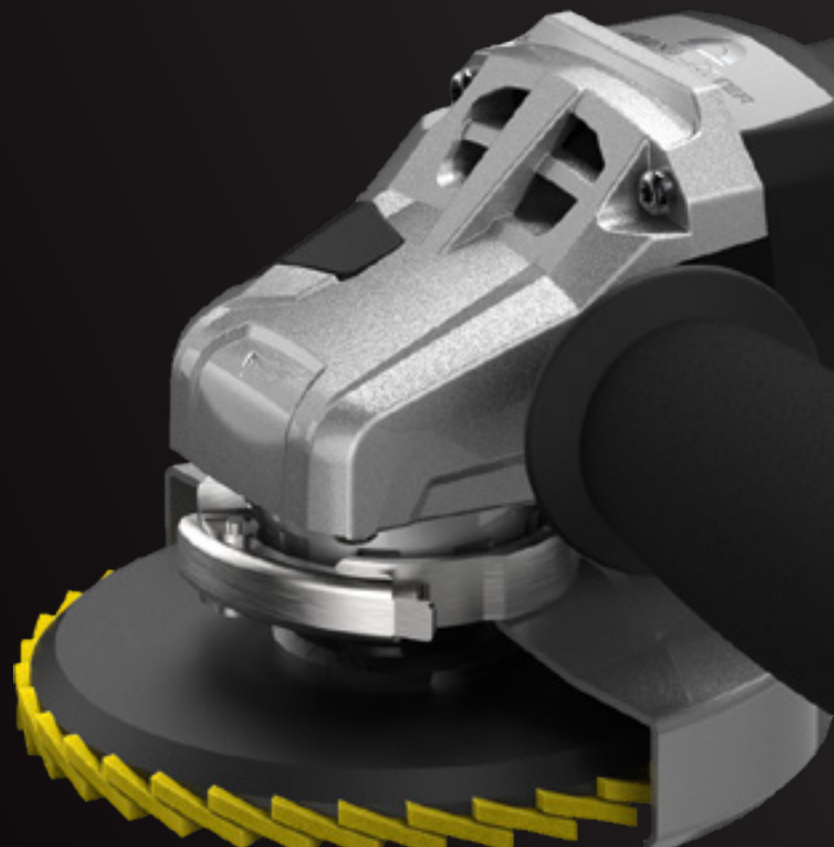

VARILEX® CAN BE DELIVERED AS A BATTERY-POWERED TOOL!
See pages 28-29

NEW 1,750-WATT MOTOR – EVEN MORE POWER

A refined motor with very high power density and a number of new features ensures completely new standards of torque, productivity, and service life.

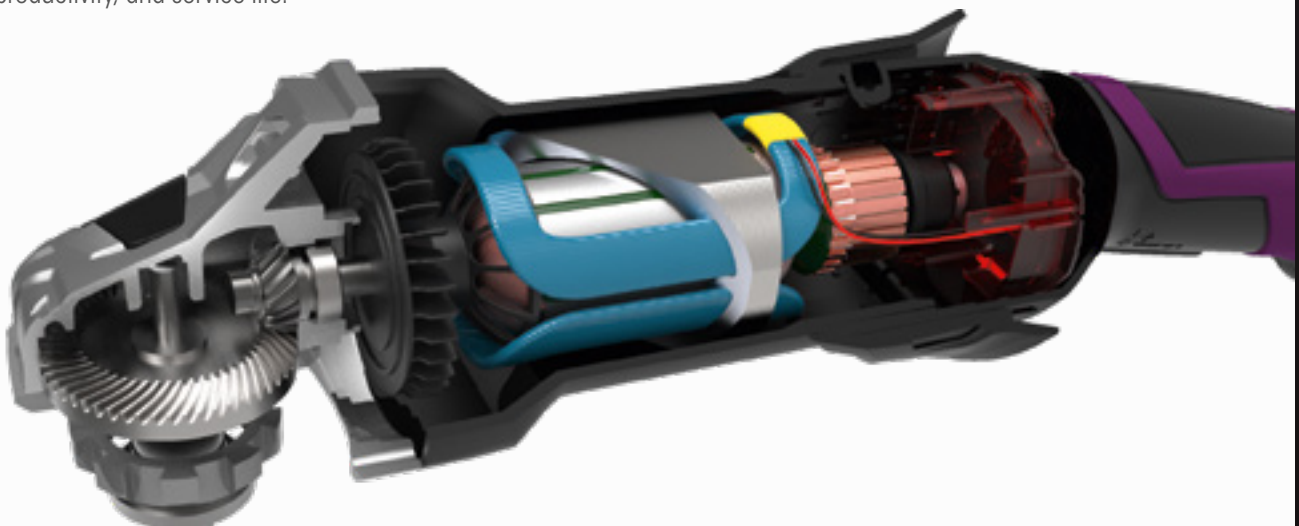



THE NEWLY DEVELOPED VARILEX® 1802 HT ANGLE GRINDER IS AMONG THE MOST ROBUST AND POWERFUL ONE-HANDED ANGLE GRINDERS IN THE WORLD AND IS MANUFACTURED ENTIRELY IN GERMANY.

DUST PREVENT SYSTEM FROM EISENBLÄTTER

The new DUST PREVENT SYSTEM (patent pending) effectively provides protection from coarse swarf and metal particles without impairing the cooling ventilation. A protective cap effectively reduces dust entering the lateral ventilation grilles. Particles bounce off the protective cap. Fresh air intake is only from the air in the rear, which is largely free of particles.



Without DUST PREVENT SYSTEM:

Coarse dust particles are taken into the ventilation grilles without any intervening protection.



With DUST PREVENT SYSTEM:

Coarse dust particles bounce off the protective cap, and air with few particles is taken in from the rear.



Alternative:

For particulate matter (with aluminium, etc.), we recommend, as an alternative to the DUST PREVENT SYSTEM, the particulate matter protection cap (see page 29).

VARILEX® 1802 HT

THE TORQUE MARVEL

OVERVIEW OF PRODUCT ADVANTAGES

- **Extremely powerful, durable motor with 1,750 watts** and optimised, wear-resistant power transmission and mechanism. With new ventilation technology for previously unattainable torques (high torque) **made entirely in Germany.**
- The newly developed, especially **ergonomic shaft handle** reduces strain on the user – at only 2.6 kg total weight, with rubberised inserts for a better grip.
- Optimised especially **for ceramic grinding discs in the speed range of 2,400-8,900 rpm,** variably and constantly adjustable with a tacho-generator for the highest efficiency.
- Spindle lock with robust, mechanical slip clutch. Prevents kickback if the tool binds.
- Ideal **angle grinder for all surface finishing,** grinding, cutting, rough grinding, cleaning, and polishing, for disc diameters of 115-150 mm.
- Balanced, vibration-damping transmission handle. Optional: **vibration-damping 3D ball handle** ensures balanced handling, even for overhead work.
- Ideal as a **stationary drive motor** for optional **flexible shafts** (M14 threads) or as a stationary motor for fixing on the workbench with the robust ball joint mount that can be delivered (optional).



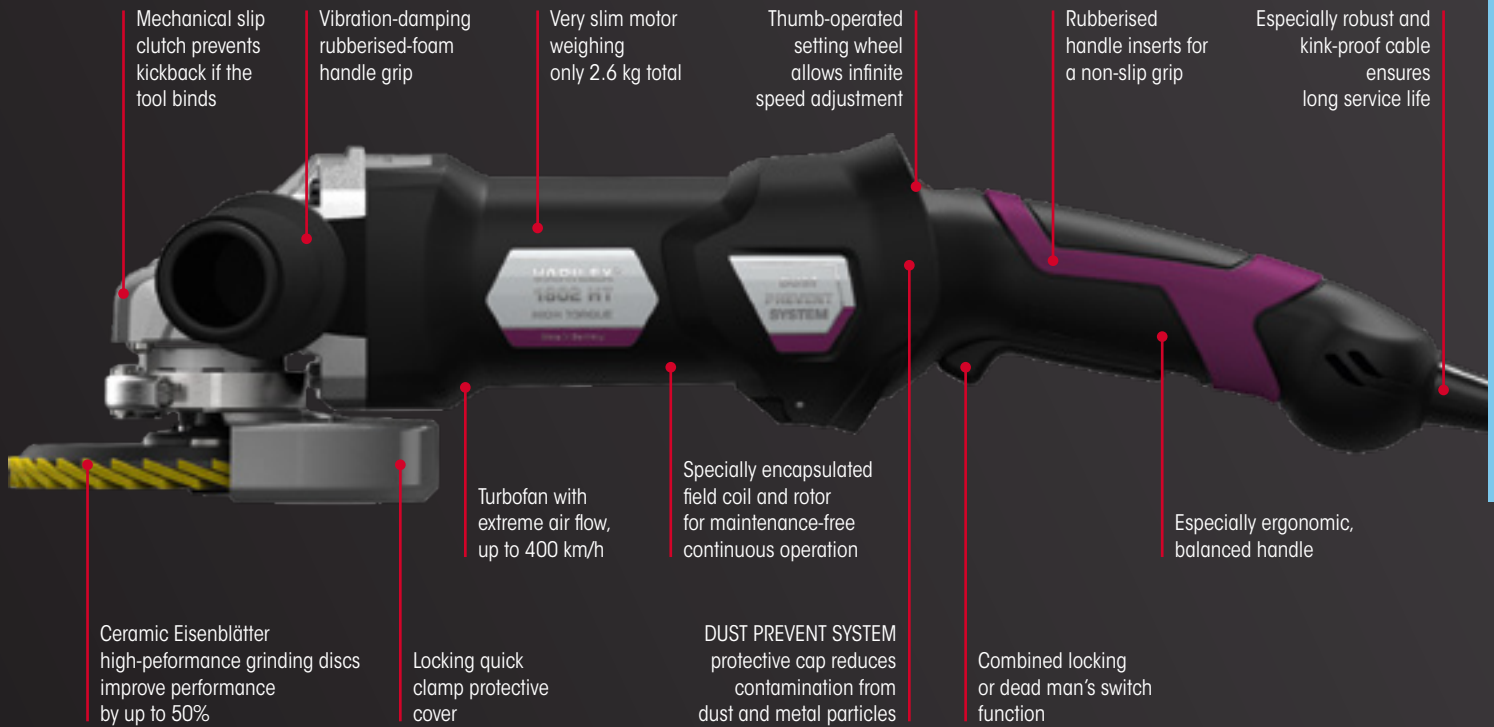

Optional: Ball joint mount (see page 289) for stationary fixing on workbenches, etc.



Optional: For the first time, the new, soft 3D ball handle allows grinding that reduces strain on the user by allowing any working position, avoiding unnatural or exhausting hand positions. This makes overhead work child's play.

Technical data VARILEX® 1802 HT basic set

Plug type	Cable type	Mains connection (V ~ Hz)	Power (W)	Mount	Speed (rpm)	Weight (kg)	Discs up to (Ø mm)	Pkg. unit	Article number
EU (C+F)	Permanent connection	220-240 ~ 50-60	1,750	M14 thread	2,400-8,900	2.6	150	1	65031
CH (J)	Permanent connection	220-240 ~ 50-60	1,750	M14 thread	2,400-8,900	2.6	150	1	65031s
UK (G)	Permanent connection	110-120 ~ 50-60	1,750	M14 thread	2,400-8,900	2.6	150	1	65031a



- Set contents:**
- 1 VARILEX® 1802 HT machine
 - 1 DUST PREVENT SYSTEM
 - 1 particulate matter protection cap
 - 1 robust, impact-resistant plastic case for machine and accessories
 - 1 protective cover up to Ø 125 mm
 - 1 clip cut-off wheel cover up to Ø 125 mm
 - 1 locking nut
 - 1 chuck key
 - 10 high-performance flap discs Ø 125 mm
 - 10 premium cutting discs Ø 125 x 1.0 mm

Please Note: For practical accessory sets, see page 32.

VARILEX® AKKU PRO HT

NEW

HIGH PULLING POWER

In order to noticeably increase the pulling power of battery-operated angle grinders and reduce the performance gap between them and normal power-cord-driven angle grinders, Eisenblätter offers a battery-powered angle grinder whose transmission and performance has been optimised.

Because of its great pulling power capacity, it is especially well-suited for use with flap discs and the multifaceted FIX HOOK & LOOP system. The speed, optimised for battery-powered machines (5,600 rpm), means that the flap disc grinding grit engages optimally and grinds cooler, preventing heat-related discolourations. The FIX HOOK & LOOP grinding and polishing system can be used for all grinding tasks, from coarse grinding to mirror finish. This means that, as of now, nearly all familiar processing steps can be performed completely cordlessly, including on construction sites or working on installation jobs.



OVERVIEW OF PRODUCT ADVANTAGES

- **Powerful 18-volt special motor**, made in Germany.
- **Top-performance** 5.5 Ah (optional 8.0 Ah) batteries, can be rotated to three positions by up to 270°.
- New **CAS** (Cordless Alliance System) battery interface: compatible with a number of drive units and makes available on the market. Dual utility and savings potential of your battery pack included – see page 15.
- **Optimised speed of 5,600 rpm** with gear reduction for **high torque**, for the FIX HOOK & LOOP system, and for the MINI FIX HOOK & LOOP system with an adapter.
- Balanced and vibration-damping handle **reduces strain on the user**.



CAS CORDLESS ALLIANCE SYSTEM

100% COMPATIBLE

metabo **ROTHENBERGER** mafell
 Collomix EISENBLÄTTER IMPACTOR
 starmix haaga STEINEL



Spindle lock

Slim, powerful 18-volt high-performance motor

Battery pack can be rotated to three positions by up to 270°

Electronic slip clutch prevents kickback if the tool binds

Locking, swivelling protective cover of up to Ø 125 mm

Optimised speed of 5,600 rpm

Particulate matter protection

5.5 Ah LiHD high-performance battery

Technical data VARILEX® AKKU PRO HT basic set

Plug type	Cable type	Mains connection (V ~ Hz)	Power (V)	Mount	Speed (rpm)	Discs up to (Ø mm)	Weight (kg)	Pkg. unit	Article number
EU (C+F)	Permanent connection	220-240 ~ 50-60	18	M14 thread	5,600	125	1.9	1	65271



- Set contents:**
- 1 VARILEX® Akku PRO HT machine
 - 1 robust, impact-resistant plastic case for machine and accessories
 - 1 particulate matter protection battery
 - 2 LiHD batteries (5.5 Ah)
 - 1 high-speed charging device including cable
 - 1 protective cover up to Ø 125 mm
 - 1 clip cut-off wheel cover up to Ø 125 mm
 - 1 locking nut
 - 1 chuck key
 - 10 high-performance flap discs Ø 125 mm
 - 10 premium cutting discs Ø 125 x 1.0 mm

Please Note: For practical accessory sets, see page 32.

POWER TOOLS

CORDLESS ALLIANCE SYSTEM

Suitable for

ALL CORDLESS ALLIANCE BATTERIES



High-speed Charging Device

NEW



For quick charging of all sliding-fit Li-ion and LiHD battery packs from 14.4 to 36 volts.

FEATURES

- **Patented "AIR COOLED" charging technology:** Batteries are cooled during charging for a much shorter charging time.
- High charging current ensures that the **battery packs are charged quickly.**
- Very **low stand-by power consumption.**
- Maximum charging current: 6.5 A.
- **Process-controlled charge management** for gentle charging and the greatest possible number of charging cycles.
- One charger for charging all battery packs from our CAS partner: www.cordless-alliance-system.de

Technical data:

Plug type	Cable type	Mains connection (V ~ Hz)	Maximum charging current (A)	Pkg. unit	Article number
EU (C+F)	Permanent connection	220-240 ~ 50-60	6.5	1	50474

Suitable for

ALL CORDLESS ALLIANCE SYSTEM DEVICES



5.5/8.0 Ah Battery

NEW



18 volts, LiHD technology

Powerful high-tech 18-volt battery (LiHD) for all battery-powered tools in the CAS group.

Technical data:

Article	Power (V)	Battery capacity (Ah)	Suitable for	Weight (kg)	Pkg. unit	Article number
5.5 Ah CAS battery	18	5.5	CAS devices	0.89	1	50463
8.0 Ah CAS battery	18	8.0	CAS devices	0.98	1	50473

Suitable for

MACHINES WITH A POWER CONNECTION

Particulate Matter Protection Cap

Greatly reduces the risk of an electronic short circuit due to metal dust

The new particulate matter protection prevents fine dust and contamination particles from entering the machine's interior and thus increase its service life. The breathable particulate matter protection can be easily cleaned and used many times. Just separate the particulate matter protection from the machine, clean it with a vacuum cleaner or blow it out with compressed air, and mount it on the machine's ventilation slots, where it will lock.

Technical data:



Can be used with:

Pkg. unit Article number

VARILEX® 1802 HT, VARILEX® POLISHER HT, POLY-PTX® 802 HT, PIPE MAX 802 HT, PIPE MAX HT MINI, PIPE SNIPER 802 HT, GLADIUS® 1802 HT

1 40084

Suitable for

MACHINES WITH A BATTERY

Battery Particulate Matter Protection Cap

Greatly reduces the risk of an electronic short circuit due to metal dust

The new particulate matter protection prevents fine dust and contamination particles from entering the machine's interior and thus increase its service life. The breathable particulate matter protection can be easily cleaned and used many times. Just separate the particulate matter protection from the machine, clean it with a vacuum cleaner or blow it out with compressed air, and mount it on the machine's ventilation slots, where it will lock.

Technical data:



Can be used with:

Pkg. unit Article number

VARILEX® AKKU PRO HT, VARILEX® POLISHER AKKU, POLY-PTX® AKKU HT, PIPE MAX AKKU, BAND-IT AKKU

1 40087

Suitable for

VARILEX® 1802 HT

Protective Cover

For safe grinding disc use. The locking mechanism makes the cover easy to change.

Technical data:

Dimensions (mm)	Packaging unit	Article number
Ø 125	1	65042
Ø 150	1	65043



Suitable for

Protective cover for VARILEX® 1802 HT - VARILEX® 1000

Cut-off Wheel Cover Clip

For using cutting discs with VARILEX® 1000 and VARILEX® 1802 HT.

Technical data:

Dimensions (mm)	Suitable for a protective cover	Packaging unit	Article number
up to 125 mm	VARILEX® 1000, VARILEX® 1802 HT	1	65045
up to 150 mm	VARILEX® 1802 HT	1	65046



Suitable for

VARILEX®

3D Ball Handle including L-shaped Holder for angle grinders with M8 mounts

For the first time, the new, soft 3D ball handle allows grinding that reduces strain on the user by allowing any working position, avoiding unnatural or exhausting hand positions. This makes overhead work child's play.

Technical data:

Suitable for	Pkg. unit	Article number
All VARILEX® machines	1	65041





Suitable for

VARILEX® 1802 HT

Protective Suction Cover for VARILEX® 1802 HT

Suction hood with a brush ring and optimised flow channel for especially low-dust indoor and outdoor grinding.

Technical data:

Article	Discs up to (Ø mm)	Connection for dust extraction (mm)	Pkg. unit	Article number
Protective suction cover	125	Ø 35/41	1	65048
Replacement brush ring	–	–	1	65055

NEW



VARILEX® 1000 One-handed Angle Grinder

The compact mini-powerhouse – professional, compact, variable-speed one-handed angle grinder for universal use. Easy-to-use one-handed angle grinder with effective capacity for flap discs of up to Ø 125 mm. Guaranteed to reduce strain on the user. Compact all-rounder you can keep with you: Ideal for use for fitting or on construction sites. Optimised speeds for a wide range of tools.

YOU CAN FIND MORE DETAILS ON PAGE 136.

NEW



POWER TOOLS

PRACTICAL ACCESSORY SETS FOR ANGLE GRINDERS

Suitable for

VARILEX® 1802 HT · AKKU PRO HT · VARILEX® 1000 · VARILEX® WSF 1800

NEW

VARILEX® Coarse and Fine Grinding Accessory Set



This set allows performance of all work, from weld seam removal to surface cleaning to fine grinding, including cleaner and surface sealant. The ideal addition to any VARILEX® angle grinder.

Technical data:

Function	Can be used with:	Pkg. unit	Article number
Coarse and fine grinding	VARILEX® 1802 HT · AKKU PRO HT · VARILEX® 1000 · VARILEX® WSF 1800	1	65032

Contents:

1 mobile tool case	1 MAGNUM® CLEAN-PLUS Ø 125 mm	1 BRIGHTEX® microfibre cloth
1 3D ball handle	1 MAGNUM® CLEAN-STRONG Ø 125 mm	1 INOX PROTECT 50 ml
5 MAGNUM® TWINFLEX® Ø 125 mm	2 MAGNUM® Fleece Top Ø 125 mm	1 BRILLIANCE CLEAN 50 ml
1 TRIMFIX® Fleece Flap 1FOR2 Ø 125 mm	1 COLDSTEEL® backing pad Ø 125 mm	1 Power Cleaner 50 ml
3 TRIMFIX® Fleece Flap Ø 125 mm	8 COLDSTEEL® fibre discs Ø 125 mm	

Suitable for

VARILEX® AKKU PRO HT · VARILEX® 1000

NEW

VARILEX® FIX HOOK & LOOP Accessory Set



The ideal FIX HOOK & LOOP accessory package for diameters **60 and 115 mm**. From coarse and fine grinding to a perfect mirror finish, including cleaner and surface sealing. The ideal addition to any VARILEX® 1000 or VARILEX® AKKU PRO HT angle grinder.

Technical data:

Function	Can be used with:	Pkg. unit	Article number
Coarse grinding to a mirror finish	VARILEX® 1000, VARILEX® AKKU PRO HT	1	65033

Contents:

1 mobile tool case	4 FIX HOOK & LOOP BRIGHTEX® polishing discs, Ø 115 mm	4 MINI FIX BRIGHTEX® polishing discs, Ø 60 mm
1 FIX HOOK & LOOP special backing pad, Ø 115 mm	1 MINI FIX special backing pad, Ø 60 mm	1 BRIGHTEX® Softclean Powder
1 FIX HOOK & LOOP soft damping adapter, Ø 115 mm	1 MINI FIX soft damping adapter, Ø 60 mm	1 BRIGHTEX® microfibre cloth
3 FIX HOOK & LOOP Cool Top®, Ø 115 mm	3 MINI FIX Cool Top®, Ø 60 mm	1 BRILLIANCE CLEAN 50 ml
8 FIX HOOK & LOOP zirconium discs, Ø 115 mm	3 MINI FIX Clean discs, Ø 60 mm	1 INOX PROTECT 50 ml
5 FIX HOOK & LOOP SC fleece discs, Ø 115 mm	5 MINI FIX SC fleece discs, Ø 60 mm	1 Power Cleaner 50 ml
3 FIX HOOK & LOOP Trizact™ discs, Ø 115 mm	3 MINI FIX Trizact™ discs, Ø 60 mm	

NEW

Suitable for

VARILEX® AKKU PRO HT · VARILEX® 1000

VARILEX® Linear Grinding and Pipe Machining Accessory Set



This accessory set turns the VARILEX® 1000 into a miniature workshop. Linear grinding, pipe machining, angular grinding – all with a single machine. The ideal addition to the VARILEX® 1000 or VARILEX® AKKU PRO HT angle grinder.

Technical data:

Function	Can be used with:	Pkg. unit	Article number
Linear and pipe grinding	VARILEX® 1000, VARILEX® AKKU PRO HT	1	65034

Contents:

- 1 mobile tool case
- 1 VARILEX® satin finishing cover
- 1 VARILEX® expansion roller, 90 x 50 mm
- 2 zirconium sleeves, 90 x 50 mm
- 3 SC fleece sleeves, 90 x 50 mm
- 4 Trizact™ sleeves, 90 x 50 mm
- 4 BRIGHTEX® polishing sleeves, 90 x 50 mm
- 1 VARILEX® grinding belt roller
- 1 high-quality corundum grinding belt, 30 x 600 mm
- 1 SC fleece belt, 30 x 650 mm
- 1 BRIGHTEX® microfibre cloth
- 1 BRILLIANCE CLEAN 50 ml
- 1 INOX PROTECT 50 ml
- 1 Power Cleaner 50 ml

THE IDEAL ADDITION FOR THESE EISENBLÄTTER MACHINES:



VARILEX® 1802 HT p. 22

VARILEX® AKKU PRO HT p. 26

VARILEX® 1000 p. 136



VARILEX® WSF 1800 p. 34

Suitable for

COARSE GRINDING TO POLISHING

VARILEX® WSF 1800



Robust, extremely powerful one-handed angle grinder with 1,750-watt output for challenging continuous operation at high torques.

FEATURES

- **Ideal drive for high-performance discs** such as TRIMFIX® HellFire®, TRIMFIX® BLACK MAMBA® and MAGNUM® Cool Top®: optimised exploitation of performance potential, ideal for work with rough grinding and cutting discs.
- Eminently suitable for **cleaning, fine grinding, and polishing of stainless steel and non-ferrous metals**, for the FIX HOOK & LOOP system and, with an adapter, for the MINI FIX HOOK & LOOP system.
- **Infinitely adjustable speed from 2,000 to 7,600 rpm** with a **tacho-generator** for constant speed, even under load.
- **Extremely powerful one-handed angle grinder** – suitable for disc sizes from 115 to 150 mm.
- **Balanced and vibration-damping transmission handle** reduces strain on the user.
- **Rubberised, ultra-ergonomic shaft handle** ensures outstanding handling and **sensitivity during work**.
- **Drive motor** for **flexible shafts** (M14 threads).



Technical data VARILEX® WSF 1800 machine

Plug type	Cable type	Mains connection (V - Hz)	Power (W)	Speed (rpm)	Mount	Weight (kg)	Discs up to (Ø mm)	Packaging unit	Article number
EU (C+F)	QUICK-LOCK	220-240 ~ 50-60	1,750	2,000-7,600	M14 thread	2.8	150	1	65000
CH (J)	QUICK-LOCK	220-240 ~ 50-60	1,750	2,000-7,600	M14 thread	2.8	150	1	65000s

Delivery scope: 1 VARILEX® WSF 1800 machine, 1 QUICK-LOCK cable (4 m), 1 protective cover (up to Ø 125 mm), 1 locking nut, 1 flap disc Ø 125 mm

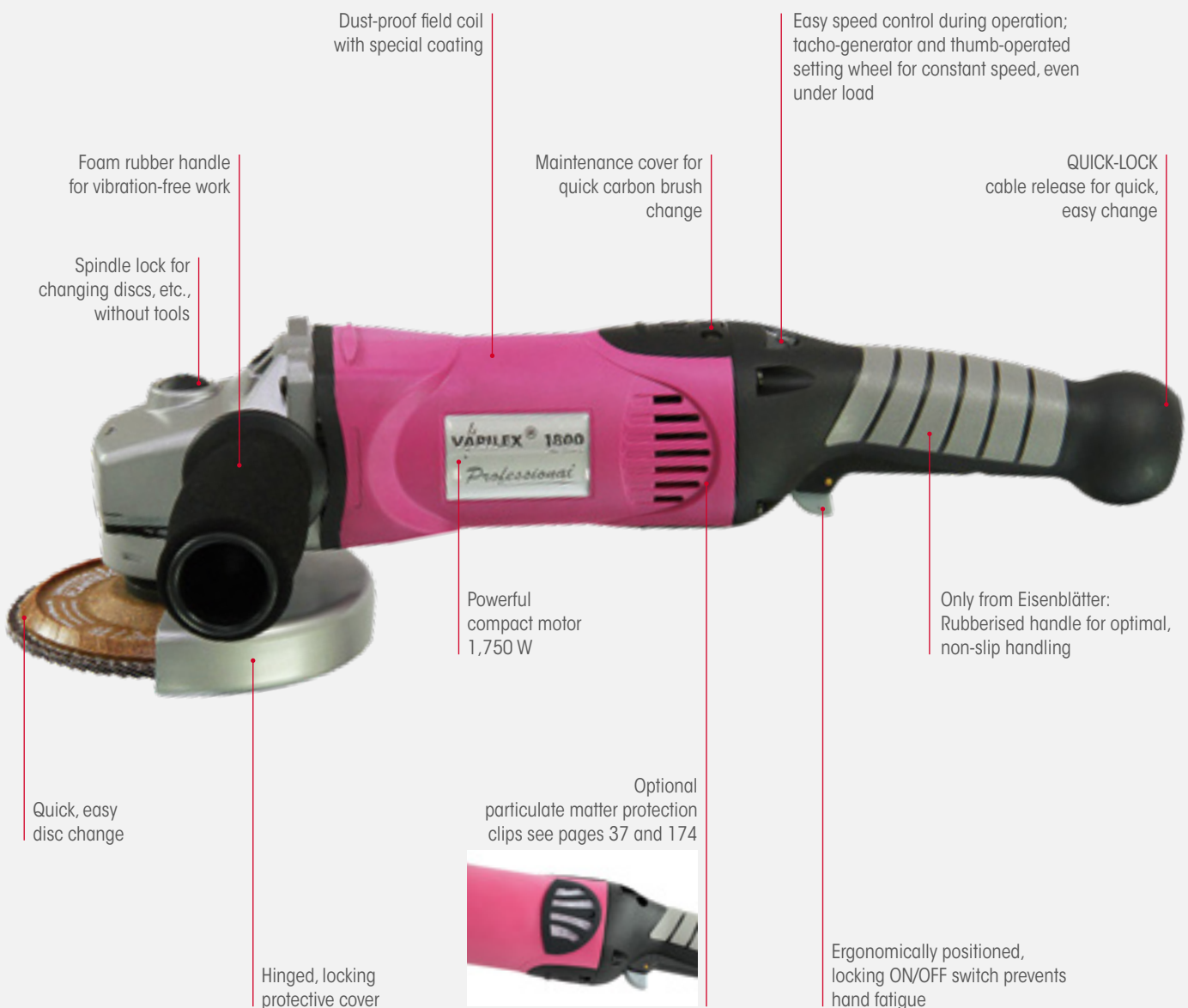

QUICK-LOCK Cable

Suitable for VARILEX® WSF 900, 1600 & 1800, POLY-PTX® 300, 500 & 800, ROLEI EF 115, PIPE MAX, PIPE SNIPER, and GLADIUS® 1800.

Technical data:

Version	Cable length (m)	Voltage (V)	Packaging unit	Article number
EU (C+F)	4	220-240	1	52004-3
EU (C+F)	10	220-240	1	52005-3
CH (J)	4	220-240	1	52004-3s
AU	4	220-240	1	52004-3a
UK (G)	4	110	1	52004-3e
US (B)	4	120	1	52004-3u
Plug adapter – EU to UK	4		1	52004d



Suitable for

VARILEX® WSF 1800

Special Protective Cover

For cutting or grinding discs.

The locking mechanism makes the cover easy to change.

Technical data:

Can be used for	Packaging unit	Article number
Discs up to Ø 125 mm	1	65020
Discs up to Ø 150 mm	1	65021
Cutting discs up to Ø 125 mm	1	65023



Locking Nut, Height-adjusting Washer, Thread Adapter from M10 to M14

Locking nut: Ultra-flat, blackened steel locking nut (just 4 mm) including chuck key for flat flange recesses and tools. For locking tools onto angle grinders.

Height-adjusting washer: Height-adjusting washer for the angle grinder spindle (for M14 only) for discs of up to Ø 178 mm with extra-long drive spindle. Also increases the contact surface area.

Thread adapter: Screw on the adapter and high-tech European discs can also be used on angle grinders produced in Asia.

Technical data:

Article	Dimensions (Ø mm)	Mount	Pkg. unit	Article number
Locking nut	45	M14	1	65004
Height-adjusting washer	up to 178	M14	1	65005
Thread adapter	M10 to M14	M10	1	65006



Particulate Matter Protection Clips

Greatly reduces the risk of an electronic short circuit due to metal dust

The new dust protection clips prevent fine dust and contamination particles from entering the machine's interior and thus increase its service life. The breathable filter fleece is easy to replace – if necessary, the operation takes a few seconds. Just remove the dust protection clip from the machine, replace the dirty filter fleece with a new one, and mount it on the machine's air intake slots, where it will lock.

NEW



Technical data:

Contents	Can be used with:	Pkg. unit	Article number
2 clips and 22 filter fleeces	POLY-PTX® 300/500/800, VARILEX® 1600/1800, PIPE MAX, PIPE SNIPER, GLADIUS® 1800, ROLEI EF 115	1	40085



Suitable for

ALL METALS



MAGNUM[®] RAZORCUT[®]



Platinum long-life cutting disc for all metals

Revolutionary cutting disc with unparalleled performance (up to 130 cuts) (test material: stainless steel pipe Ø 27 mm with 2-mm wall thickness). The high-performance cutting disc is remarkable for its high precision, aggressive cutting speed, and extremely long service life.

FEATURES

- The disc thickness of only 1 mm allows **exceptionally precise cuts**.
- Ideally **suited to all metals** – simplifies material procurement and storage.
- Up to **50% better performance** than conventional products.
- Considerably fewer disc changes means huge **working time savings**.

Technical data:

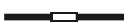
Dimensions (mm)	Thickness (mm)	Maximum speed (rpm)	Approved for (DIN EN 12413)	Shape	Hardness	Packaging unit	Article number
Ø 125 x 22.2	1	12,200	80 m/sec	 straight	hard	25	85122



Suitable for

ALL METALS



MAGNUM® FINECUT

Premium cutting disc

Special high-performance cutting disc for thin-walled profiles and pipes and premium quality job.



Technical data:

Dimensions (mm)	Thickness (mm)	Maximum speed (rpm)	Approved for (DIN EN 12413)	Shape	Hardness	Packaging unit	Article number
Ø 115 x 22.2	1	13,300	80 m/sec	straight	hard	25	85111
Ø 125 x 22.2	1	12,200	80 m/sec	straight	hard	25	85112



Suitable for

ALL METALS



MAGNUM® TWINFLEX®

Cutting and rough grinding in a single disc

The combination disc allows cutting and rough grinding with a single product. It is indispensable during jobs where workers are constantly changing discs over. Ideally suited for alternating cutting and grinding applications.



Technical data:

Dimensions (mm)	Thickness (mm)	Maximum speed (rpm)	Shape	Hardness	Approved for (DIN EN 12413)	Packaging unit	Article number
Ø 125 x 22.2	2.5	12,200	off-set	hard	80 m/sec	25	85412



CUTTING AND ROUGH GRINDING

Suitable for

ALL METALS



MAGNUM[®] FLEXO

Premium rough grinding disc

The outstanding features of this universal rough grinding disc are its great aggressiveness, long service life, and material removal performance. Ideal for stainless steel. Eminently suited for difficult deburring jobs.



FEATURES

- **Suited to all metals** – simplifies material procurement and storage.
- Considerably fewer disc changes means **huge working time savings.**

Technical data:

Dimensions (mm)	Thickness (mm)	Maximum speed (rpm)	Approved for (DIN EN 12413)	Shape	Hardness	Pkg. unit	Article number
Ø 125 x 22.2	6	12,200	80 m/sec	 off-set	Medium	10	85312



UNRIVALLED TECHNOLOGY AND PERFORMANCE

Flap Discs

At the end of the 1970s, Eisenblätter developed the first zirconium-based flap disc for high-speed angle grinders. This led to the unprecedented triumph of flap disc that today are well-known on all continents. This makes EISENBLÄTTER the initiator of and precursor to today's flap discs. Almost 50 years of experience in flap disc innovation and manufacture give us unrivalled technology, and we are now one of the biggest manufacturers in the world. In terms of environmental friendliness, material removal, durability, and quality, Eisenblätter flap discs are among the very best in the world and constitute an industry benchmark.

Simply superb

Material removal, grinding quality, and service life:
The grit mix and abrasive cloth and the right combination of elastic backing material, flap angle, hard compression, and gluing system ensure performance and service life.

Environmentally and user-friendly

At Eisenblätter, we attach the greatest value to environmental user-friendliness in our selection of raw materials. We don't use glass fibre, mineral fibres, or epoxy resins in our products. We use sustainable, renewable raw materials to produce our flap discs. Right from the start, we've used food-grade special plastics for our backing plates. Eisenblätter's greatest contribution to environmental friendliness, high-tech components, and user protection was the development of its natural-fibre-compound backing plate. This revolutionary technology raised grinding technology to a new level. Today, it offers the highest in resource conservation and environmental friendliness. The grit mix and abrasive cloth were refined and many grinding processes simplified and revolutionised.

This provides:

- Improved adaptation to the workpiece because of the elasticity offered by all backing technologies available from Eisenblätter
- Self-trimming, which for the first time allows 100% of the abrasive cloth to be used
- No troublesome fibre glass dust
- Reduced noise level and vibrations
- Maximum service life for all components because of painstaking test procedures and unique patented manufacturing processes

Unique, revolutionary manufacturing processes

The special manufacturing process gives the abrasive cloth its necessary moisture and elasticity, greatly extending fabric durability.

The abrasive flaps are anchored and hard-compressed in an elastic system. This has an enormously positive effect on flap disc service life.

Safety, quality, tests

A great deal of testing apparatus and many robots are in use every day to test and ensure the systems' high performance. But manual tests are also important for simulating extreme conditions.

Many of our products are also tested and certified by MPA Hannover, one of the oldest and most experienced official materials testing institutes in Germany.





100% NATURAL FIBRE COMPOUND

0% FIBRE GLASS

ONLY FROM EISENBLÄTTER!

Natural fibre compound

MPA
tested

Eisenblätter products with natural fibre backing plates

The invention and development of the natural fibre compound backing plate for abrasive technology began an entirely new chapter in grinding disc production with respect to performance, technology, and environmental friendliness. The years of experience in developing natural fibre technology have culminated in superior surface machining from which customers always benefit in daily use.



Grinds down to the last millimetre

Backing plates made of natural fibre compound trim themselves during the grinding process. Trimming during machining is also simple and easy (it gives off a pleasant wood chip smell). Flap discs with natural fibre compound backing plates can be used right down to the last millimetre of abrasive cloth.

Trimming leaves soft, harmless shavings which can be disposed of as household waste.

Easy trimming during operation

Flap discs with natural fibre compound backing plates have a fibre substrate with damping, even elastic properties that enhance their performance in grinding operations. This backing plate elasticity allows better adjustment, a larger contact surface area on the workpiece (more grit being used), and, of course, more material removal. The greater contact surface area dissipates more heat, grinding is cooler, the workpiece does not tarnish as easily, and the abrasive cloth does not burn.

Advantages of natural fibre compound backing plates

- 100% made in Germany
- Much greater elasticity and better workpiece adaptation
- Large grinding area results in low grinding temperatures
- Self-trimming properties for up to 100% use of the abrasive cloth
- This allows immediate cost savings of at least 30-40%
- Heat insulation, damping properties
- Lower noise level and less vibration during grinding
- No danger of injury from sharp fibre glass edges
- No fibre glass dust in the air
- Backing plates are resistant to most chemicals
- Very great work safety
- Sustainable raw materials ensure a low CO₂ footprint



Quality has been certified by the MPA Hanover materials testing agency

Ideal workpiece adaptation with a viscoelastic backing plate

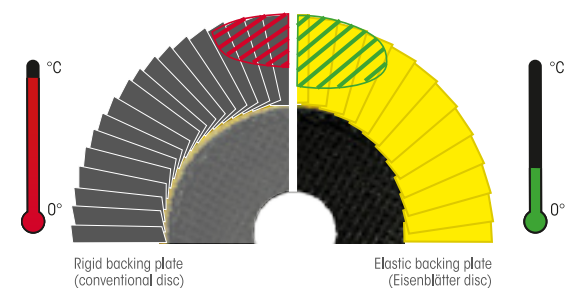

The patented Eisenblätter production process means that only Eisenblätter grinding discs are truly flexible. This allows not only more efficient work, but also reduced grinding temperature due to the larger workpiece support area.

GRINDING AND BLENDING

FLAP DISCS ON A NATURAL FIBRE COMPOUND

Suitable for

ALL METALS

TRIMFIX® HellFire® Ceramic Hybrid

One disc for all metals



The TRIMFIX® HellFire® is one of the most modern, versatile flap discs in the world. Its unparalleled, innovative ceramic hybrid technology, enables it to machine any metal in record time with a single grit. It is user-friendly (no glass fibre components) and environmentally friendly (uses CO₂-neutral natural fibre components). Working time and tool costs are halved – and all at an absolutely outstanding price-performance ratio.

FEATURES

- 40 grit material removal with 60 grit grinding results.
- Multigrain (40/60) **saves on extra storage required for different grits.**
- **New ceramic hybrid fabric** allows workpiece grinding with just one grit in the coarse-to-medium grit range.
- Fewer work steps at the highest level of performance.
- Elastic, **high-tech natural fibre compound backing plate** is easy on the environment and the user (CO₂-neutral), fully trimmable so that the entire disc can be used, damps noise and vibration.
- Especially soft grinding transitions thanks to **ideal workpiece adaptation.**

The TRIMFIX® HellFire® achieves the same high grinding performance on all metals.



Technical data TRIMFIX® HellFire®

Dimensions (mm)	Ideal speed (rpm)	Maximum speed (rpm)	Approved for (DIN EN 13743)	Backing plate	Packaging unit	Grit (K)	Article number
Ø 100 x 16.0	8,000-10,000	15,000	80 m/sec	Natural fibre	40	Multigrain 40/60	91521
Ø 115 x 22.2	7,000-9,000	13,200	80 m/sec	Natural fibre	40	Multigrain 40/60	91530
Ø 125 x 22.2	6,000-8,000	12,200	80 m/sec	Natural fibre	40	Multigrain 40/60	91540
Ø 150 x 22.2	6,000-7,000	10,000	80 m/sec	Natural fibre	40	Multigrain 40/60	91547
Ø 178 x 22.2	5,000-6,000	8,500	80 m/sec	Natural fibre	40	Multigrain 40/60	91549

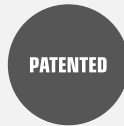
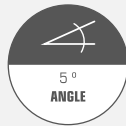

Elastic, **high-tech natural fibre compound backing plate** is easy on the environment and the user (CO₂-neutral), fully trimmable so that the entire disc can be used, damps noise and vibration

TRIMFIX® HellFire® guarantees first-class work results

Even extremely hard, tough steel, such as Leopard 2 tank gun tube, can be easily machined with great results.

Ceramic hybrid cloth
One disc with one grit grinds from coarse to medium in a single operation

Multigrain (40/60)
saves on extra storage required for different grits

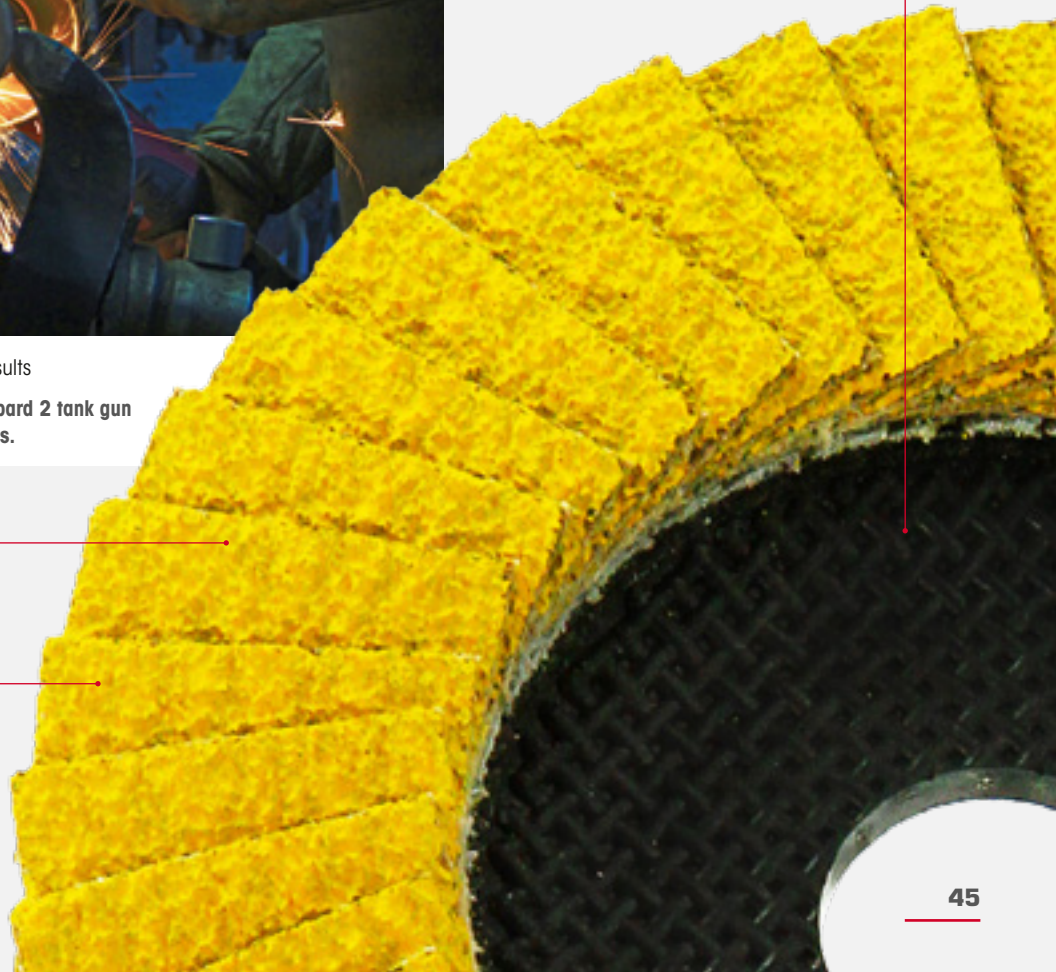

GRINDING AND BLENDING

FLAP DISCS ON A NATURAL FIBRE COMPOUND

Suitable for

STEEL

TRIMFIX® SteelFire®

The performance marvel on steel – unprecedented flap disc steel removal



In order to counter the growing pressure of labour costs, Eisenblätter is launching a new generation of flap discs for steel machining based on 45 years of experience in developing cutting-edge grinding tools. This revolutionary product was developed especially for high-performance areas in steel construction such as shipyards, bridge-building, railroads, energy-sector construction, and building construction and civil engineering: anywhere where it is important to work effectively in the shortest possible time. The special formulation with hybrid grit technology and patented arrangement of abrasive cloth ensures material removal rates that were unimaginable a short time ago.

FEATURES

- High-tech **zirconium hybrid flap disc**, especially for time-saving high-speed steel removal.
- **Uniform grinding results and cool grinding** – without discolouration.
- Elastic, **high-tech natural fibre compound backing plate** is easy on the environment and the user (CO₂-neutral), fully trimmable so that the entire disc can be used, damps noise and vibration.
- The viscoelastic backing plate ensures optimum workpiece adaptation for **particularly soft grinding transitions**.
- **Great labour savings** (see the sample calculation on p. 73 and at www.eisenblaetter.de).
- Its **enormous material removal** and rapid grinding effect lead us to recommend a performance-optimised, **variable-speed**, high-torque angle grinder – **VARILEX® 1802 HT** from Eisenblätter meets every element of this description and is the ideal counterpart for the TRIMFIX® SteelFire® flap disc.
- Also suitable for stainless steel (Fe-S-CI<0.1%).



The newly developed high-torque VARILEX® 1802 HT angle grinder greatly shortens work time and reduces labour costs. For potential cost savings, see p. 73.

Technical data TRIMFIX® SteelFire®

Dimensions (mm)	Ideal speed (rpm)	Maximum speed (rpm)	Approved for (DIN EN 13743)	Backing plate	Packaging unit	Grit (K)	Article number
Ø 115 x 22.2	7,000-9,000	13,200	80 m/sec	Natural fibre	40	40	91364
						60	91366
Ø 125 x 22.2	6,000-8,000	12,200	80 m/sec	Natural fibre	40	40	91374
						60	91376
Ø 150 x 22.2	6,000-7,000	10,000	80 m/sec	Natural fibre	40	40	91384
						60	91386
Ø 178 x 22.2	5,000-6,000	8,500	80 m/sec	Natural fibre	40	40	91394
						60	91396

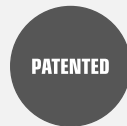
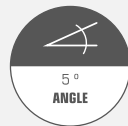

The zirconium hybrid cloth ensures consistent performance and long service life to the end of the disc

Elastic, high-tech natural fibre compound backing plate is easy on the environment and the user (CO₂-neutral), fully trimmable so that the entire disc can be used, damps noise and vibration



High-speed steel removal with extremely long service life. The low-cost way to grind!

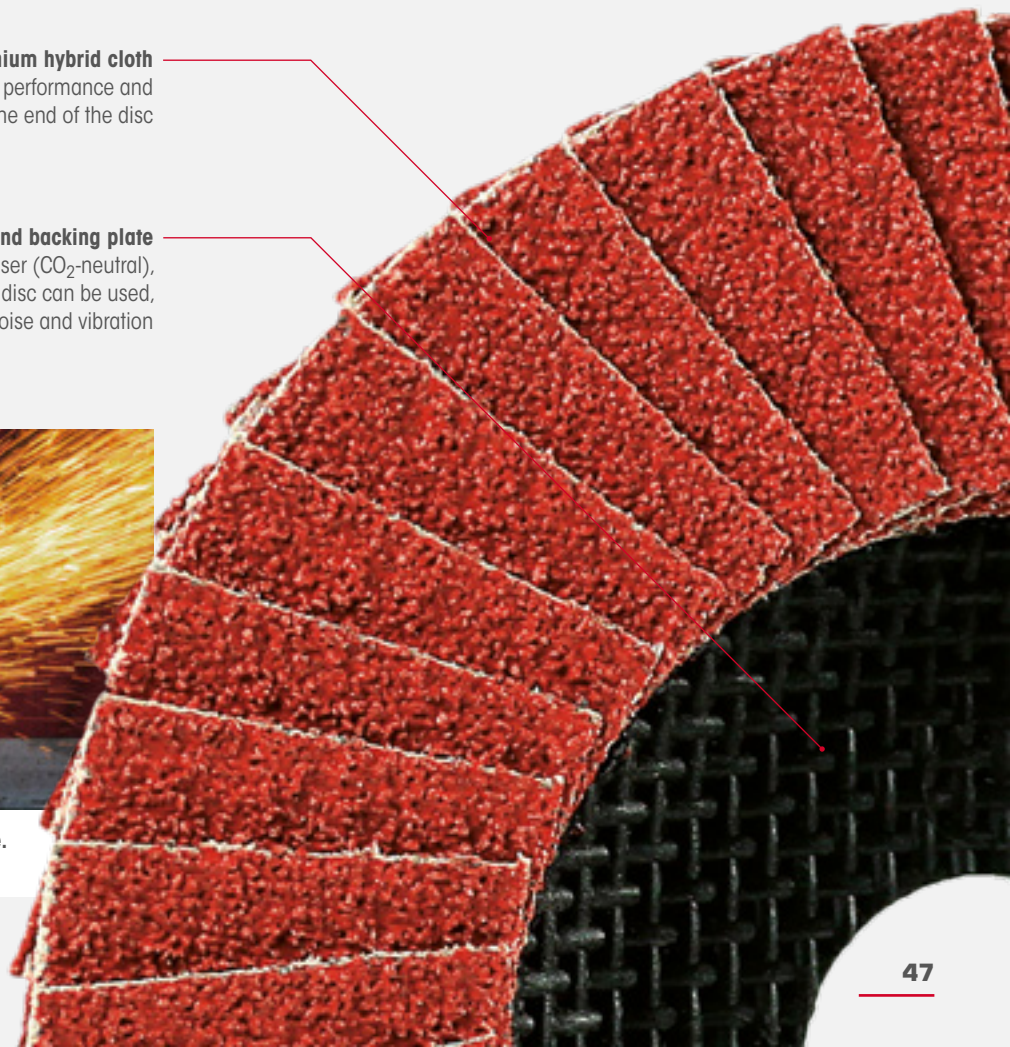

POWER GRINDING WITH COMPACT TOOLS

HEAVY-DUTY

POWER GRINDING



Shipyards, ships, bridge-building, heavy-duty steel construction, etc.

Eisenblätter is introducing heavy-duty flap discs in Ø 125 mm for the first time. Their material removal is the same as conventional flap discs of Ø 180 mm.

HellFire® and SteelFire® Heavy-Duty exceed all previous removal rates for conventional flap discs.

The newly developed **high-torque VARILEX® 1802 HT** angle grinder greatly shortens work time and reduces **labour costs**. For potential cost savings, see p. 73.

NEW

TRIMFIX® HellFire®
Heavy-Duty p. 50

NEW

TRIMFIX® SteelFire®
Heavy-Duty p. 52

GRINDING AND BLENDING

FLAP DISCS ON A NATURAL FIBRE COMPOUND

Suitable for

ALL METALS

TRIMFIX® HellFire® Heavy-Duty

Power grinding with compact tools



Eisenblätter is introducing heavy-duty flap discs in Ø 125 mm for the first time. Their material removal is the same as conventional flap discs of Ø 180 mm.

The HellFire® Heavy-Duty flap discs exceed all previous removal rates for conventional flap discs for all metals. The newly developed high-torque VARILEX® 1802 HT angle grinder greatly shortens work time and reduces labour costs. For potential cost savings, see p. 73.

FEATURES

- **Ceramic hybrid cloth with extra-wide flaps.**
- **Unrivalled material removal** in a very short time.
- Huge **work time and cost savings (can be more than €20,000)** (see sample calculations on page 73).
- **Large flap overhang** for work in corners.
- With **integrated M14 threads** for quick tool changes without tools.
- **Also suitable** for robotic grinding applications.
- **Patented flap configuration.**
- **The fastest and cheapest way to grind!** Absolutely requires a **high-torque angle grinder such as VARILEX® 1802 HT.**
- Elastic, **high-tech natural fibre compound backing plate** is easy on the environment and the user (CO₂-neutral), fully trimmable so that the entire disc can be used, damps noise and vibration.
- **Please Note:** Not suitable for angle grinder of less than 1,600 watts!



Technical data TRIMFIX® HellFire® Heavy-Duty

Dimensions (mm)	Ideal speed (rpm)	Maximum speed (rpm)	Approved for (DIN EN 13743)	Backing plate	Packaging unit	Grit (K)	Article number
Ø 125 x M14	6,000-8,000	12,200	80 m/sec	Natural fibre	20	Multigrain 40/60	91331



Elastic, **high-tech natural fibre compound backing plate** is easy on the environment and the user (CO₂-neutral), fully trimmable so that the entire disc can be used, damps noise and vibration

Ceramic hybrid cloth
One disc with one grit grinds from coarse to medium in a single operation

Multigrain (40/60)
saves on extra storage required for different grits

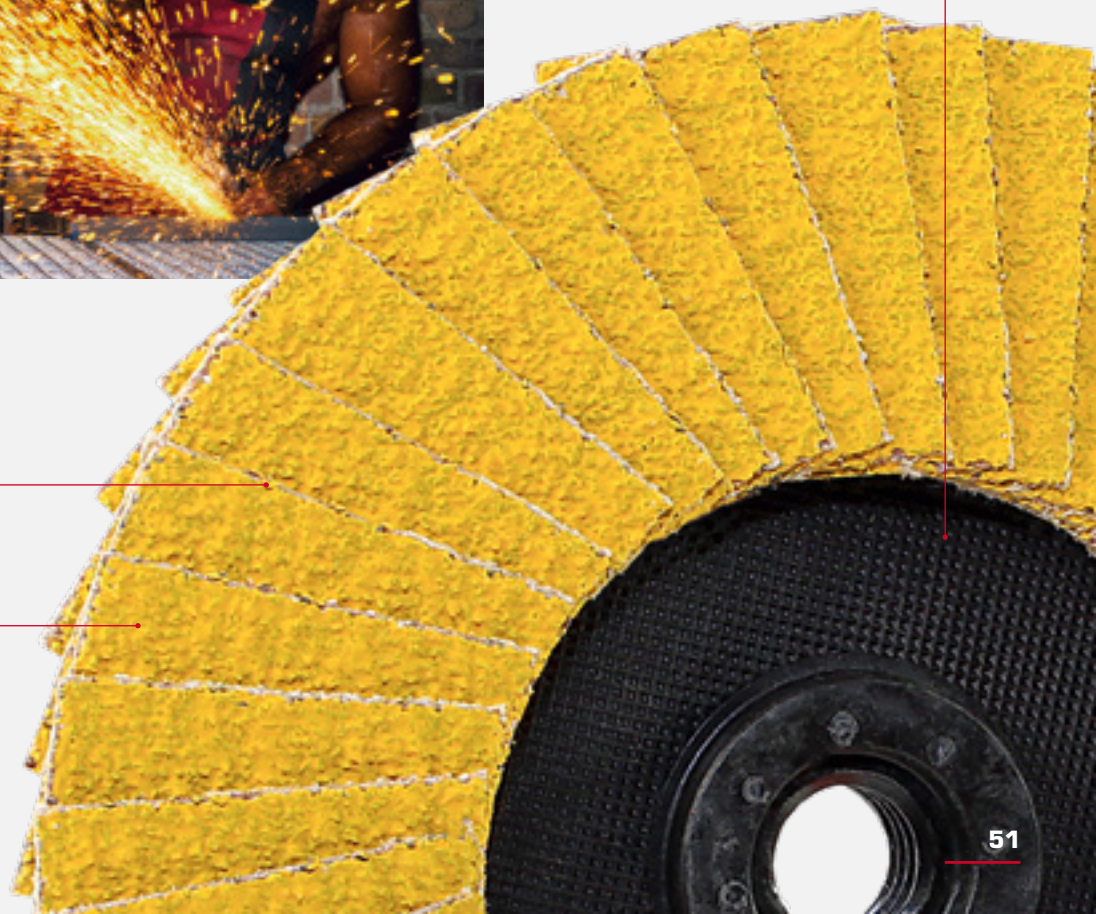

GRINDING AND BLENDING

FLAP DISCS ON A NATURAL FIBRE COMPOUND

Suitable for

STEEL

TRIMFIX® SteelFire® Heavy-Duty

Power grinding with compact tools



Eisenblätter is introducing heavy-duty flap discs in Ø 125 mm for the first time. Their material removal is the same as conventional flap discs of Ø 180 mm.

The SteelFire® Heavy-Duty flap discs exceed all previous removal rates for conventional flap discs for steel. The newly developed high-torque VARILEX® 1802 HT angle grinder greatly shortens work time and reduces labour costs. For potential cost savings, see p. 73.

FEATURES

- Zirconium hybrid cloth with **extra-wide flaps**.
- **Unrivalled material removal** in a very short time.
- Huge **work time and cost savings (can be more than €20,000)** (see sample calculations on page 73).
- **Large flap overhang** for work in corners.
- With **integrated M14 threads** for quick tool changes without tools.
- **Also suitable** for robotic grinding applications.
- **Patented flap configuration**.
- **The fastest and cheapest way to grind!** Absolutely requires a **high-torque angle grinder such as VARILEX® 1802 HT**.
- Elastic, **high-tech natural fibre compound backing plate** is easy on the environment and the user (CO₂-neutral), fully trimmable so that the entire disc can be used, damps noise and vibration.
- Also suitable for stainless steel (Fe-S-CI<0.1%).
- **Please Note:** Not suitable for angle grinder of less than 1,600 watts!



Technical data TRIMFIX® SteelFire® Heavy-Duty

Dimensions (mm)	Ideal speed (rpm)	Maximum speed (rpm)	Approved for (DIN EN 13743)	Backing plate	Packaging unit	Grit (K)	Article number
Ø 125 x M14	6,000-8,000	12,200	80 m/sec	Natural fibre	20	40	91342
						60	91343

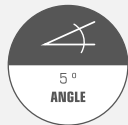

The zirconium hybrid cloth ensures consistent performance and long service life to the end of the disc

Elastic, **high-tech natural fibre compound backing plate** is easy on the environment and the user (CO₂-neutral), fully trimmable so that the entire disc can be used, damps noise and vibration



GRINDING AND BLENDING

FLAP DISCS ON A NATURAL FIBRE COMPOUND

Suitable for

STEEL · STAINLESS STEEL

TRIMFIX® BLACK MAMBA®

One of the most powerful flap discs in the world



The TRIMFIX® BLACK MAMBA® is a high-performance flap disc for steel. It is designed to deliver extremely long service life and exceptional material removal for modern steel machining operations. The newly developed pure zirconium cloth with cooling agents and great abrasive content makes it ideal for machining all grades of steel up to stainless steel. The backing plate is made of natural fibre and is environmentally and user-friendly while adjusting flexibly to the workpiece, guaranteeing smooth grinding transitions. The TRIMFIX® BLACK MAMBA® can be trimmed, allowing significant tool cost saving. Up to 4 kg of steel can be removed using just one BLACK MAMBA® Ø 125 mm grit 40 disc.

FEATURES

- The **high-performance flap disc** offers **exceptional service life and material removal** for steel and stainless steel.
- **Newly developed pure zirconium cloth** with cooling agents guarantee cool grinding and performance throughout the service life.
- Sets new performance records with a **nominal removal rate of up to 4 kg of steel (depending on grit size)**.
- Ideal workpiece adaptation ensures especially **soft grinding transitions**.
- Elastic, **high-tech natural fibre compound backing plate** is easy on the environment and the user (CO₂-neutral), fully trimmable so that the entire disc can be used, damps noise and vibration.



Technical data TRIMFIX® BLACK MAMBA®

Dimensions (mm)	Ideal speed (rpm)	Maximum speed (rpm)	Approved for (DIN EN 13743)	Backing plate	Packaging unit	Grit (K)	Article number
Ø 100 x 16.0	8,000-10,000	15,000	80 m/sec	Natural fibre	40	40	91704
						60	91706
Ø 115 x 22.2	7,000-9,000	13,200	80 m/sec	Natural fibre	40	40	91714
						60	91716
Ø 125 x 22.2	6,000-8,000	12,200	80 m/sec	Natural fibre	40	40	91724
						60	91726
Ø 150 x 22.2	6,000-7,000	10,000	80 m/sec	Natural fibre	40	40	91734
						60	91736
Ø 178 x 22.2	5,000-6,000	8,500	80 m/sec	Natural fibre	40	40	91744
						60	91746

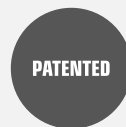

100% pure zirconium fabric
Exceptionally long service life and durability with steel and stainless steel

Elastic, **high-tech natural fibre compound backing plate** is easy on the environment and the user (CO₂-neutral), fully trimmable so that the entire disc can be used, damps noise and vibration

This disc can remove up to one kilogram of steel in 15-20 minutes. The cool grinding makes it eminently suitable for stainless steel.

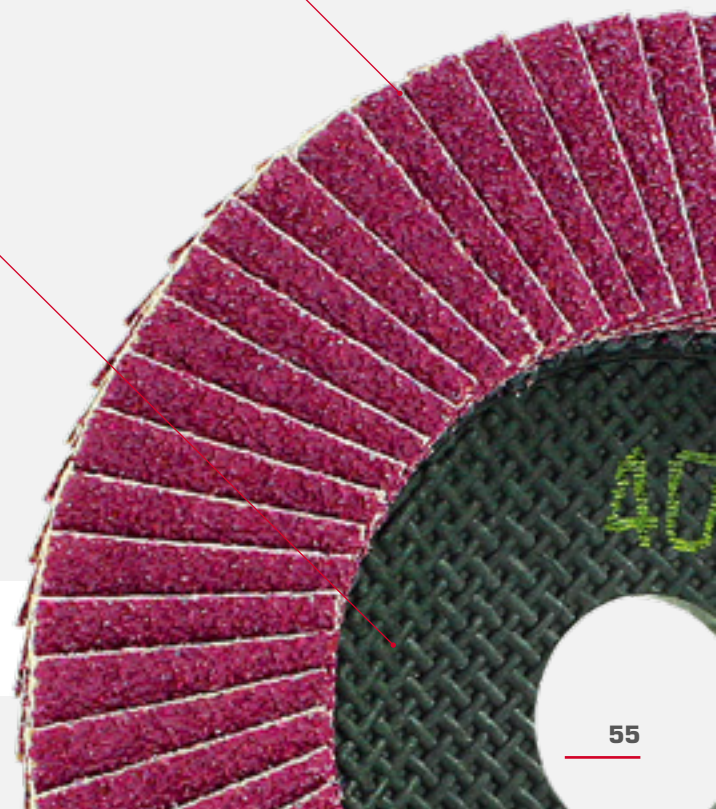

GRINDING AND BLENDING

FLAP DISCS ON A NATURAL FIBRE COMPOUND

Suitable for

STEEL · STAINLESS STEEL

TRIMFIX® ZIRCOPUR®

For universal grinding work on steel and stainless steel

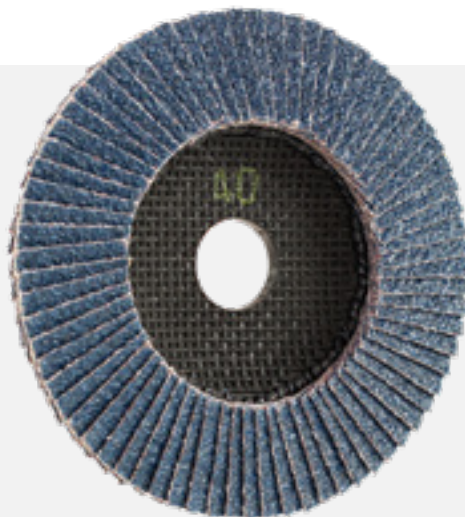

The quality flap disc with its revolutionary TRIMFIX® backing plate technology is equipped with high-tech zirconium fabric for first-rate grinding results at an unbeatable price for this superb quality.

The viscoelastic backing plate of natural fibre compound allows the disc to adapt perfectly to the workpiece surface. Available in all commonly used sizes and grits, it is a universal aid you can rely on.

FEATURES

- **High-tech zirconium cloth** for great grinding performance on steel and stainless steel.
- Very good grinding results with **unbeatable price-performance ratio**.
- Ideal workpiece adaptation ensures especially **soft grinding transitions**.
- Elastic, **high-tech natural fibre compound backing plate** is easy on the environment and the user (CO₂-neutral), fully trimmable so that the entire disc can be used, damps noise and vibration.



Technical data TRIMFIX® ZIRCOPUR®

Dimensions (mm)	Ideal speed (rpm)	Maximum speed (rpm)	Approved for (DIN EN 13743)	Backing plate	Packaging unit	Grit (K)	Article number
Ø 100 x 15.2	8,000-10,000	15,000	80 m/sec	Natural fibre	40	40	91500
						60	91501
						80	91502
						120	91503
Ø 100 x 16.0	8,000-10,000	15,000	80 m/sec	Natural fibre	40	40	91504
						60	91506
						80	91508
						120	91509
Ø 115 x 22.2	7,000-9,000	13,200	80 m/sec	Natural fibre	40	40	91514
						60	91516
						80	91518
						120	91519
Ø 125 x 22.2	6,000-8,000	12,200	80 m/sec	Natural fibre	40	40	91524
						60	91526
						80	91528
						120	91529
Ø 150 x 22.2	6,000-7,000	10,000	80 m/sec	Natural fibre	40	40	91574
						60	91576
						80	91578
						120	91579
Ø 178 x 22.2	5,000-6,000	8,500	80 m/sec	Natural fibre	40	40	91580
						60	91581
						80	91582
						120	91583

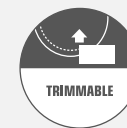
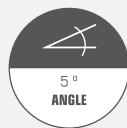

High-tech zirconium cloth
Easy-to-use, cool grinding,
even in continuous operation

Elastic, **high-tech natural fibre compound backing plate**
is easy on the environment and the user (CO₂-neutral),
fully trimmable so that the entire disc can be used,
damps noise and vibration

Grit available in all commonly used
industrial **dimensions and grits**

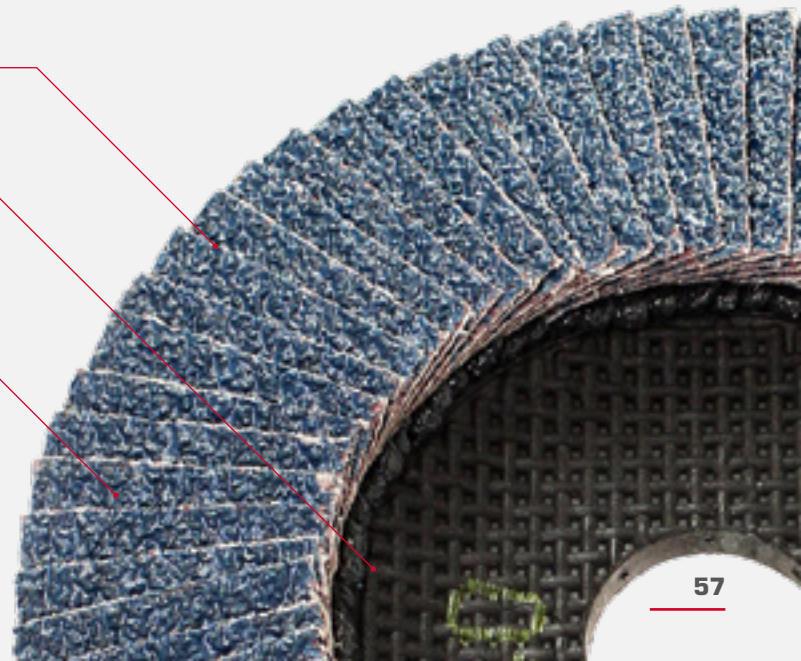

GRINDING AND BLENDING

FLAP DISCS ON A NATURAL FIBRE COMPOUND

Suitable for

STEEL · STAINLESS STEEL · NON-FERROUS METALS · HARD PLASTICS

PLANTEX® Cool Top® Universal

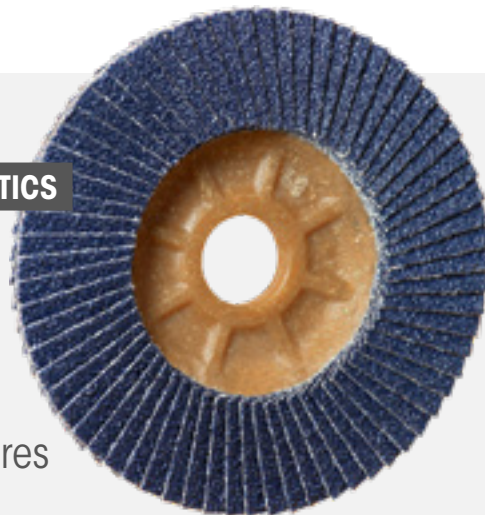

Its 100% pure zirconium on 100% cotton cloth ensures outstanding grinding behaviour on all materials

Since Eisenblätter launched the first flap disc with pure zirconium cloth for high-speed angle grinders at the end of the 1970s, it has repeatedly had innovative ideas that decisively influenced the development of the flap disc. Natural fibre compound is an ideal material for backing plates. With the development of this new manufacturing technique, PLANTEX® Cool Top® Universal became the first flap disc in the world with a backing plate of renewable hemp.

FEATURES

- **Ultra-safe to work with.**
- Conserves resources and is **environmentally friendly.**
- **Minimises pollution from manufacture to disposal.**
- **Absorbs heat** (hollow-fibre insulation reduces temperature during grinding).
- Elastic, **high-tech natural fibre compound backing plate** is easy on the environment and the user (CO₂-neutral), fully trimmable so that the entire disc can be used, damps noise and vibration.
- **Easy to dispose of.**
- **Superb insulating**, damping, and noise-reducing qualities.
- High strength at **low weight.**
- Exhibits great dimensional stability while remaining **flexible.**
- **Resistant** to most **chemicals.**
- **Good energy-CO₂ balance.**



Technical data PLANTEX® Cool Top® Universal

Dimensions (mm)	Ideal speed (rpm)	Maximum speed (rpm)	Approved for (DIN EN 13743)	Backing plate	Packaging unit	Grit (K)	Article number
Ø 115 x 22.2	7,000-9,000	13,200	80 m/sec	Natural fibre	10	40	92140
						60	92160
						80	92180
						120	92190
Ø 125 x 22.2	6,000-8,000	12,200	80 m/sec	Natural fibre	10	40	92240
						60	92260
						80	92280
						120	92290
Ø 178 x 22.2	5,000-6,000	8,500	80 m/sec	Natural fibre	10	40	92340
						60	92360
						80	92380
						120	92390

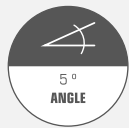

100% pure zirconium with grinding additives on 100% cotton for an extremely wide range of applications

Elastic, high-tech natural fibre compound backing plate is easy on the environment and the user (CO₂-neutral), fully trimmable so that the entire disc can be used, damps noise and vibration

Approximate content ratio (proportions in the backing plate)

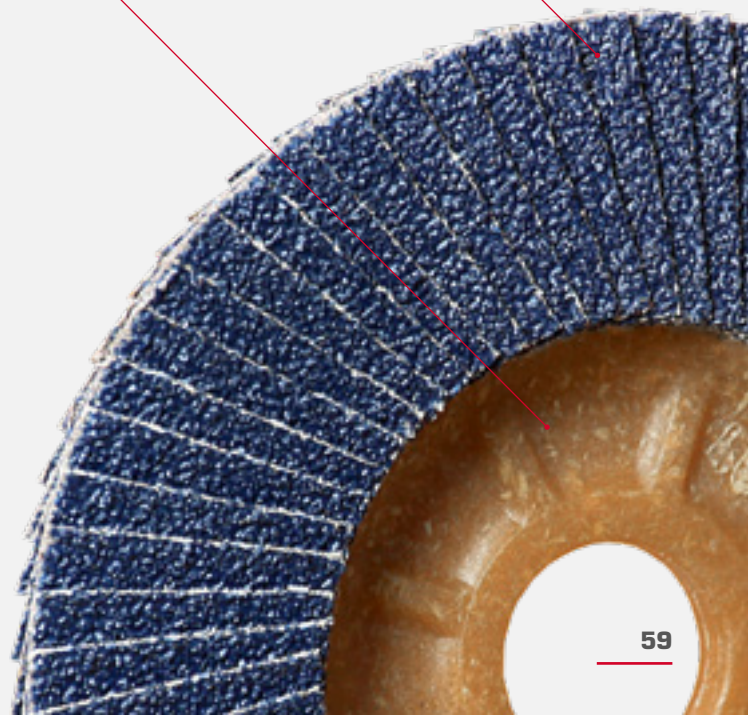
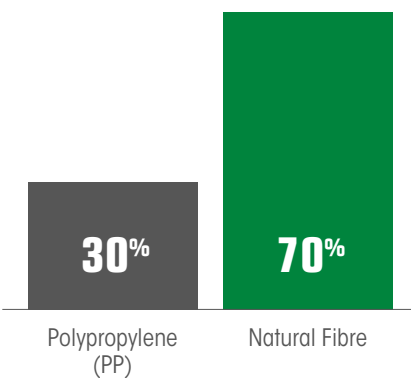

GRINDING AND BLENDING

FLAP DISCS

Suitable for

STEEL · STAINLESS STEEL

MAGNUM[®] Cool Top[®] 5⁺

The legendary, original MAGNUM[®] high-performance-flap disc with extremely high fabric content for extremely long service life



FEATURES

- Long, quick, efficient grinding. Has been the price-performance benchmark for years.
- The **ultra-powerful zirconium flap disc** with a backing plate of food-grade plastic.
- **Can be used universally** for **steel, cast iron, and stainless steel**. For surface and edge grinding, coarse and intermediate grinding, machining fillet welds, removing rust, deburring, and cleaning castings.
- In many companies, it **replaces** not only **fibre discs**, but also **rough grinding discs**.
- Backing plate of specially developed flexible, food-grade plastic: **easy to trim, damps vibration, and completely free of glass fibre**.

The continuous runner among flap discs!
The original – Eisenblätter's MAGNUM[®]



Technical data MAGNUM® Cool Top® 5+

Dimensions (mm)	Ideal speed (rpm)	Maximum speed (rpm)	Approved for (DIN EN 13743)	Backing plate	Packaging unit	Grit (K)	Article number
Ø 115 x 22.2	7,000-9,000	13,200	80 m/sec	special flexible plastic	10	40	96140b
						60	96160b
						80	96180b
						120	96190b
Ø 125 x 22.2	6,000-8,000	12,200	80 m/sec	special flexible plastic	10	40	96240b
						60	96260b
						80	96280b
						120	96290b
Ø 178 x 22.2	5,000-6,000	8,500	80 m/sec	special flexible plastic	10	40	96340b
						60	96360b
						80	96380b



Backing plate made from specially developed flexible, food-grade plastic: **easy to trim, damps vibration, and completely free of glass fibre**

Legendary abrasive formulation

Pure zirconium plus cooling agent guarantees huge benefits compared to conventional flap discs: Often up to 50% faster in removing material, many times the service life of conventional flap discs with cooler grinding due to additional cooling agents

Steel material removal in 15 minutes (steel/ST37)

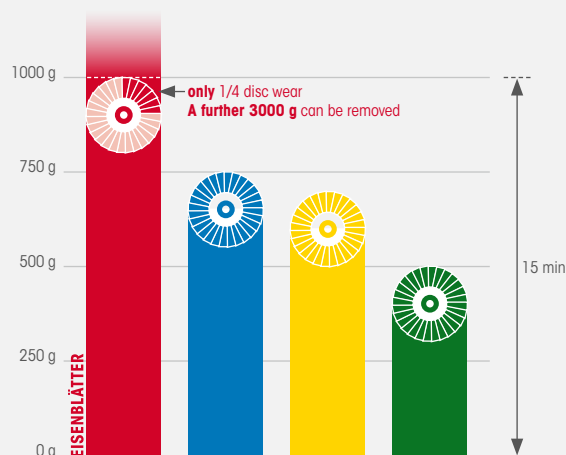

	Ø disc	Material removal in 15 minutes	Approx. maximum overall performance
A – top quality	125 mm	1000 g	> 4000 g
B – high quality	125 mm	750 g	2500 g
C – medium quality	125 mm	650 g	1500 g
D – low quality	125 mm	500 g	750 g



GRINDING AND BLENDING

FLAP DISCS

Suitable for

STEEL · STAINLESS STEEL

MAGNUM® Fillet Weld

High-performance flap disc with great flap overhang – a problem-solver in corners



FEATURES

- For perfect **low-cost machining of corner, edge, and fillet welds.**
- The large, **flexible overhang of the abrasive flaps** over the backing plate adjusts perfectly to the shape of a fillet weld.
- **Smooth blends on corner welds.**
- Clean, **groove-free results.**
- The same grinding performance and service life as the MAGNUM® Cool Top® 5+.
- Backing plate of specially developed flexible, food-grade plastic: **easy to trim, damps vibration, and completely free of glass fibre.**
- Legendary abrasive formulation (pure zirconium plus cooling agent) guarantees huge benefits compared to conventional flap discs: Often up to 50% faster in removing material, many times the service life of conventional flap discs with **cooler grinding due to additional cooling agents.**



Technical data MAGNUM® Fillet Weld

Dimensions (mm)	Ideal speed (rpm)	Maximum speed (rpm)	Approved for (DIN EN 13743)	Backing plate	Packaging unit	Grit (K)	Article number
Ø 125 x 22.2	6,000-8,000	12,200	80 m/sec	special flexible plastic	10	40	96284
						60	96286
						80	96288
						120	96289

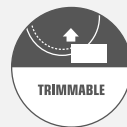
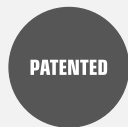
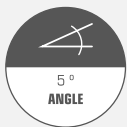
**Legendary abrasive formulation**

Pure zirconium plus cooling agent guarantees huge benefits compared to conventional flap discs:
Often up to 50% faster in removing material, many times the service life of conventional flap discs with cooler grinding due to additional cooling agents

The wide flap overhang guarantees soft transitions and easy access to corners

Backing plate made from specially developed food-grade, flexible plastic:
easy to trim, flexible, damps vibration, and completely free of glass fibre

Designed for rounding off
weld seams in corners

The disc can be machined to trim it
for use right down to the last millimetre



125 x 22 mm
5" x 7/8"

Art.-Nr.

K40 96284

K60 96286

K80 96288

K120 96289

Int. Patent u.
Design
protection

DIN EN13743

80 m/sec

GRINDING AND BLENDING

FLAP DISCS

Suitable for

ALL METALS

MAGNUM[®] Ceramic

Ceramic high-performance flap disc with exceptional grinding performance on all metals and hard-to-grind materials



FEATURES

- Advanced **high-performance ceramic disc for maximum performance.**
- **Extremely time-saving** for stainless steel, steel, titanium, and bronze removal.
- **Exceptionally cool grinding behaviour** prevents discolouration.
- Backing plate of specially developed flexible, food-grade plastic: **easy to trim, damps vibration, and completely free of glass fibre.**
- Trimmable backing plate allows complete use of all abrasive flaps.
- Elasticity provides damping and noise-reducing properties.

The continuous runner among flap discs!
The original – Eisenblätter's MAGNUM[®].



Technical data MAGNUM® Ceramic

Dimensions (mm)	Ideal speed (rpm)	Maximum speed (rpm)	Approved for (DIN EN 13743)	Backing plate	Packaging unit	Grit (K)	Article number
Ø 125 x 22.2	6,000-8,000	12,200	80 m/sec	special flexible plastic	10	40	96624
						60	96626
						80	96628



High-performance ceramic formulation
Highest grinding performance on all metals

Backing plate made from specially developed food-grade, flexible plastic:
easy to trim, flexible, damps vibration, and completely free of glass fibre

EISENBLÄTTER Ceramic self-sharpening process

The existing grinding force breaks off sintered microcrystals, continuously giving the grit new, sharp cutting edges.

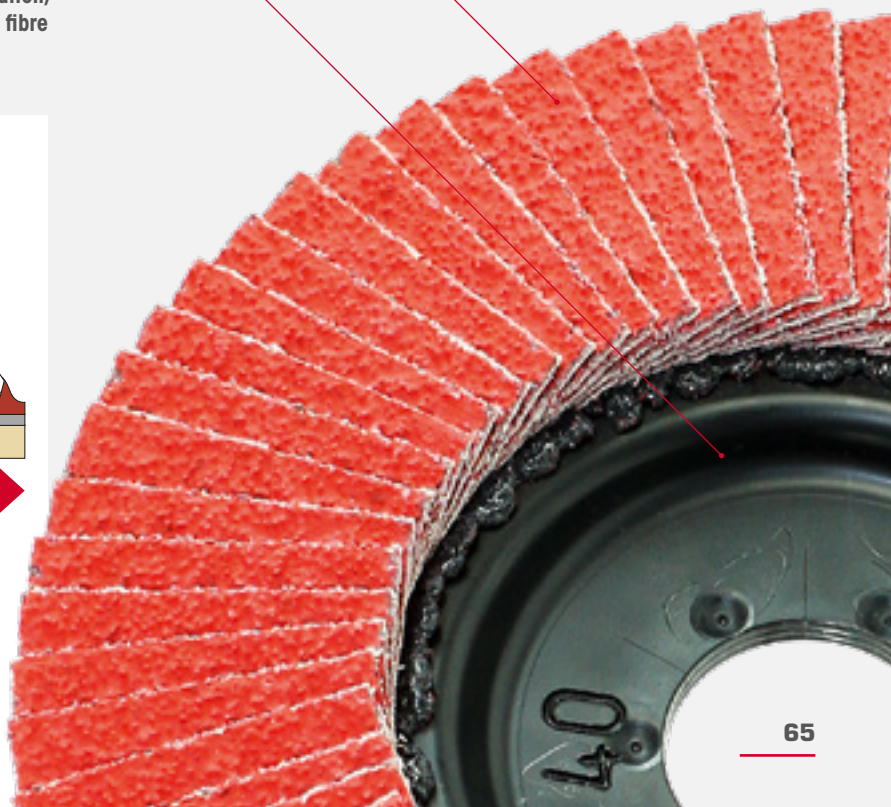
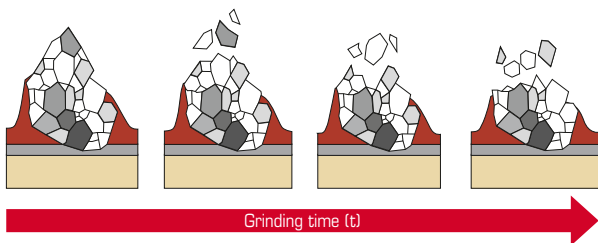

GRINDING AND BLENDING

FLAP DISCS

Suitable for

STEEL · CAST IRON · STAINLESS STEEL

BLUE SHARK® Elastic

Highly flexible flap disc with zirconium cooling layers for especially smooth, flat finishes, ideally suited for use in sheet metal working, with a particularly long service life and superb cooling effect



FEATURES

- **Highly flexible, especially damping flap disc** with low overall height.
- For exceptionally **smooth, flat finishes** for such operations as the surface grinding of large constructions.
- The **highly flexible** backing plate allows the grinding disc to adjust ideally to the workpiece surface.
- Cooler grinding behaviour makes it ideal for **sheet metal**.
- The effective **contact surface area is larger**, so heat dissipation is considerably greater. **This largely prevents workpiece discolouration.**
- Backing plate of specially developed food-grade, flexible corrugated plastic: **easy to trim, damps vibration, and completely free of glass fibre.**
- Larger contact surface area ensures much **longer service life** than that of conventional flap discs.



Technical data BLUE SHARK® Elastic

Dimensions (mm)	Ideal speed (rpm)	Maximum speed (rpm)	Approved for (DIN EN 13743)	Backing plate	Packaging unit	Grit (K)	Article number
Ø 115 x 22.2	7,000-9,000	13,200	80 m/sec	special flexible plastic	10	40	94140e
						60	94160e
						80	94180e
						120	94190e
Ø 125 x 22.2	6,000-8,000	12,200	80 m/sec	special flexible plastic	10	40	94240e
						60	94260e
						80	94280e
						120	94290e
Ø 178 x 22.2	5,000-6,000	8,500	80 m/sec	special flexible plastic	10	40	94340
						60	94360

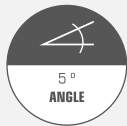

Abrasive formulation with cooling agents
allows great material removal

The disc can be machined to trim it for
use right down to the last millimetre

Backing plate made from specially developed food-grade, flexible plastic:
easy to trim, flexible, damps vibration, and completely free of glass fibre

Large contact surface area due to great elasticity provided by **unique corrugation**

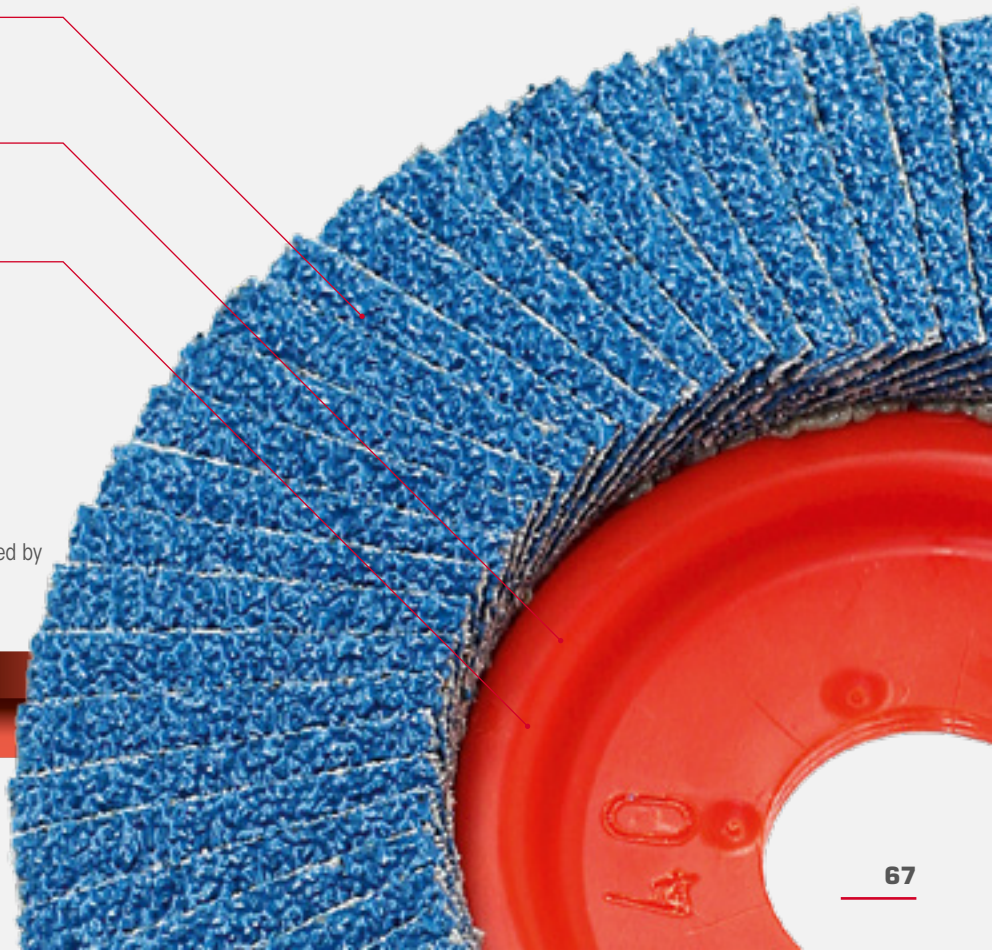

GRINDING AND BLENDING

FLAP DISCS

Suitable for

ALUMINIUM · STEEL · NON-FERROUS METALS

TIGER SHARK® Elastic

Highly flexible flap disc with cooling effect for smooth, flat grinding surfaces – ideal for machining aluminium



FEATURES

- The special corundum abrasive cloth prevents smearing during aluminium grinding.
- TIGER SHARK® + ALU-FIX OIL deliver up to 300% more material removal and three times the service life.
- Visibly improved grinding results.
- The highly flexible backing plate allows the grinding disc to adjust ideally to the workpiece surface.
- High grinding performance at low tool costs.
- High material removal capacity at reduced grinding temperature.
- Ideal for curved surfaces and shaped pieces such as those encountered in car bodywork, motor vehicle workshops, and railway carriage and tool construction.
- Backing plate of specially developed food-grade, flexible corrugated plastic: easy to trim, damps vibration, and completely free of glass fibre.

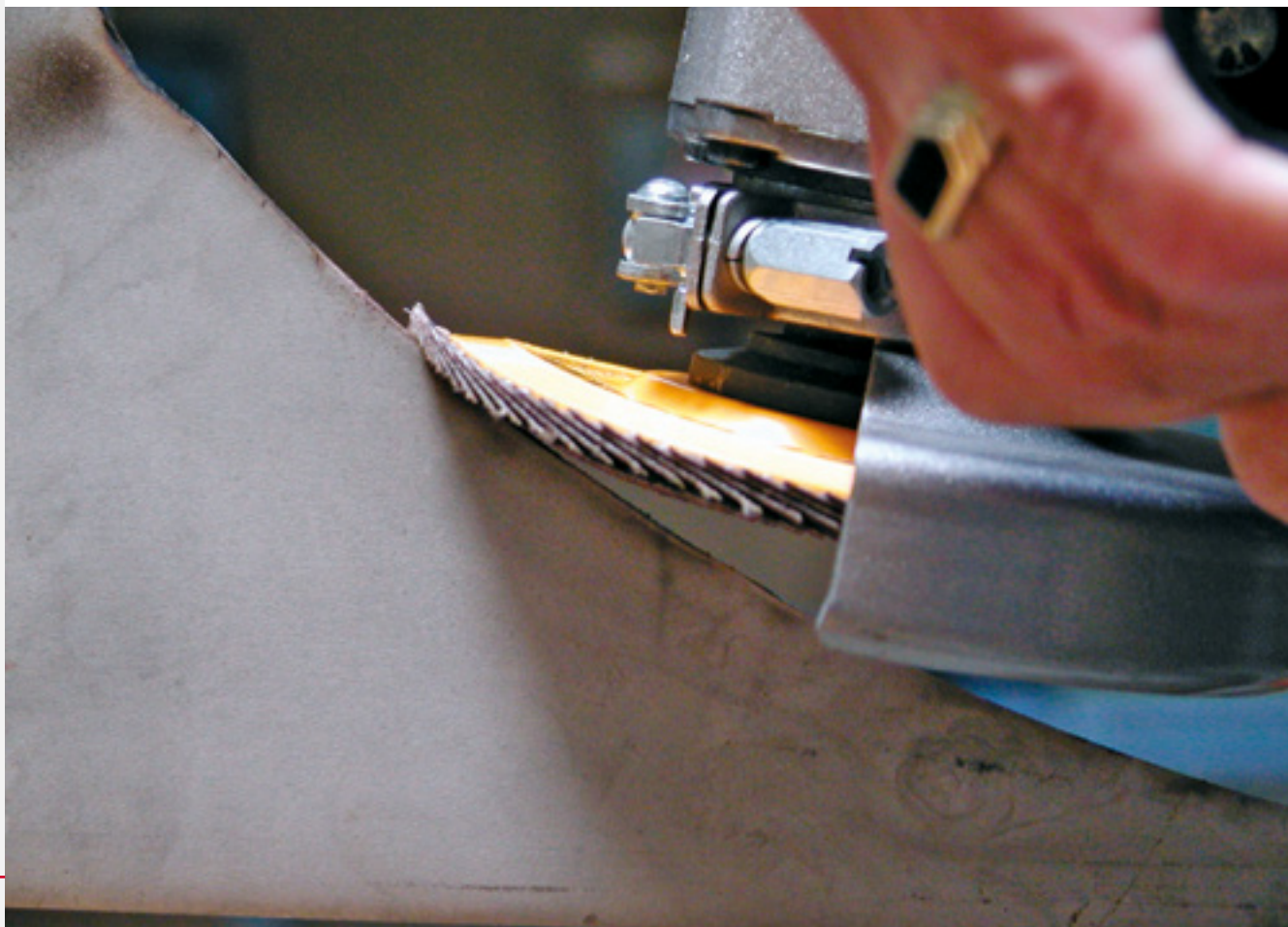

Technical data TIGER SHARK® Elastic

Dimensions (mm)	Ideal speed (rpm)	Maximum speed (rpm)	Approved for (DIN EN 13743)	Backing plate	Packaging unit	Grit (K)	Article number
Ø 115 x 22.2	7,000-9,000	13,200	80 m/sec	special flexible plastic	10	40	94114
						60	94116
						80	94118
						120	94119
Ø 125 x 22.2	6,000-8,000	12,200	80 m/sec	special flexible plastic	10	40	94124
						60	94126
						80	94128
						120	94129
Ø 178 x 22.2	5,000-6,000	8,500	80 m/sec	special flexible plastic	10	40	94134
						60	94136

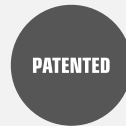
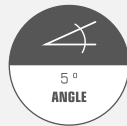

Special corundum abrasive cloth
No smearing during aluminium grinding for aluminium

Backing plate made from specially developed food-grade, flexible plastic: **easy to trim, flexible, damps vibration, and completely free of glass fibre**

The disc can be machined to trim it for use right down to the last millimetre – ideal for machining aluminium

TIGER SHARK® + ALU-FIX OIL

Achieves up to 300% more material removal and ensures a service life that is up to three times as long!

PAGE 280



Large contact surface area due to great elasticity provided by **unique corrugation**

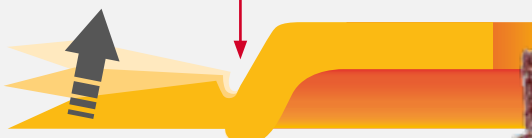

GRINDING AND BLENDING

FLAP DISCS

Suitable for

STEEL · STAINLESS STEEL · CAST IRON · NON-FERROUS METALS · ALUMINIUM

ZIRCOTEX® Nylon Flat

The legendary flat flap disc –
ideal for levelling weld seams on flat surfaces

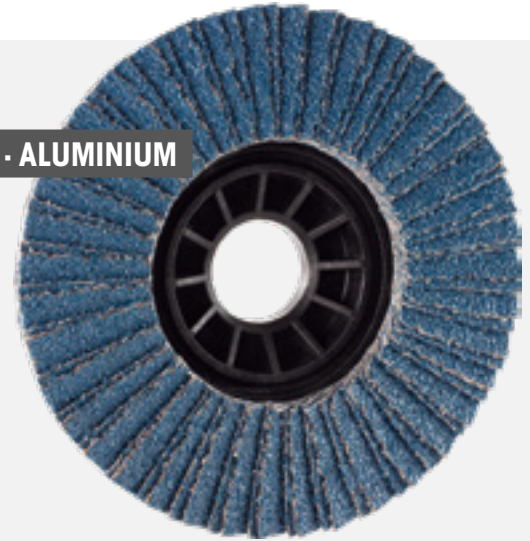

FEATURES

- **Extremely wide zirconium double flaps** (30 mm at Ø 115 mm) improve heat distribution and enhance the cooling effect.
- **Service life is around 50 times** that of conventional corundum fibre discs.
- For rough grinding, smoothing, and cleaning weld seams and spot welds.
- Very large abrasive surface for a **long service life**.
- **Flat contact area for perfect weld blending** on outer edges (weld seam edges).
- Ideal for flat surfaces, switch cabinet construction, and welding assemblies.
- Suitable as an alternative to the ROLEI EF 115 deburring tool (page 258).

Technical data:

Dimensions (mm)	Ideal speed (rpm)	Maximum speed (rpm)	Approved for (DIN EN 13743)	Backing plate	Packaging unit	Grit (K)	Article number
Ø 115 x 22.2	7,000-8,000	13,200	80 m/sec	Polyamide	10	40	21040
						50	21050
						60	21060
						80	21080
						120	21120

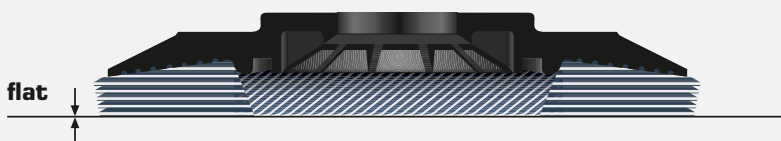

Flap Disc Test Box

This is where you can find the ideal grinding disc for your individual application

The **ten best high-tech flap discs in a single box**, including sales documents.

Technical data:

Product description	Pkg. unit	Article number
Test box with 10 different high-tech grinding discs	1	99316



Set contents:

- 1 TRIMFIX® ZIRCOPUR® 125 x 22.2 mm, 40 grit
- 1 TRIMFIX® BLACK MAMBA® 125 x 22.2 mm, 40 grit
- 1 TRIMFIX® HellFire® 125 x 22.2 mm, Multigrain 40/60
- 1 TRIMFIX® HellFire® Heavy-Duty 125 mm x M14, Multigrain 40/60
- 1 TRIMFIX® SteelFire® 125 x 22.2 mm, 40 grit
- 1 TRIMFIX® SteelFire® Heavy-Duty 125 mm x M14, Multigrain 40/60
- 1 PLANTEX® Cool Top® Universal 125 x 22.2 mm, 40 grit
- 1 BLUE SHARK® Elastic 125 x 22.2 mm, 40 grit
- 1 TIGER SHARK® Elastic 125 x 22.2 mm, 40 grit
- 1 MAGNUM® Cool Top® 5+ 125 x 22.2 mm, 40 grit

Suitable for

STEEL · STAINLESS STEEL · NON-FERROUS METALS

Cool Top® Flap Disc

Quick-change mini zirconium flap disc. Ultra-long service life; high material removal; uniform, clean results without material discolouration; adjusts ideally to the workpiece.

Available for these quick-change systems:



FIX HOOK & LOOP
MORE DETAILS ON P. 143



MINI FIX HOOK & LOOP
MORE DETAILS ON P. 124

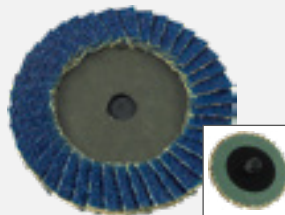

PINLOC
MORE DETAILS ON P. 132



Change discs in seconds with the Eisenblätter FIX HOOK & LOOP and MINI FIX systems. Centring pin ensures that the disc runs perfectly.

NEW! MANY NEW PRODUCTS NOW AVAILABLE WITH THE PINLOC SYSTEM!

See pages 128.



Improve performance with Eisenblätter products!



Earn money while you grind! Increase your employees' efficiency!

AVERAGE COST OF LABOUR

Average work time
for one grinding
employee per year:

2,000 h
PER YEAR

Average cost for the company
per hour (including ancillary
costs and social benefits):

€35/h

Average cost to the company
per grinding employee per year:

€70,000

USE EISENBLÄTTER PRODUCTS – GIVE YOUR EMPLOYEES MORE POWER:

High-torque one-handed angle grinder with optimised
speed combined with ...



VARILEX® 1802 HT
One-handed angle grinder

... High-tech flap discs with high material removal and long service life



+ TRIMFIX® SteelFire®, HellFire®
or BLACK MAMBA®

30-40%
IMMEDIATE PERFORMANCE JUMP!

SAVINGS POTENTIAL FOR LABOUR COSTS
FROM FEWER OPERATING HOURS

More than €20,000 /year

From shorter set-up times, longer grinding, and greater material removal with Eisenblätter products!

Efficiency in perfection: Flap discs from Eisenblätter!

Do cheap discs pay? A cost comparison.

EISENBLÄTTER flap discs

Cost pro disc approx. € 1.85
for such brands as TRIMFIX®, SteelFire®, HellFire®, or BLACK MAMBA®



4.5 kg

60 min

9,000 kg
2,000 h x Ø 4.5 kg



Cheap zirconium flap discs

Cost per disc approx. €1.00



1.25 kg

30 min

5,000 kg
2,000 h x Ø 2.5 kg



Ø
MATERIAL REMOVAL PRO DISC
steel (S235JR/ST37)

Ø
CHARGE

GRINDS PER YEAR

4.5 kg/h
1 disc

2.5 kg/h
= 2 discs x 1.25 kg

For material removal of 9,000 kg, you need approx.

2,000 SteelFire® / €3,700
x approx. €1.85 per disc

7,200 cheap zirconium discs / €7,200
x approx. €1.00 per disc

Average work time per grinding employee per year

€3,500 tool cost savings
€24,500 labour cost savings
(35% of € 70,000)

= €28,000!

Can you do afford to pass that up?

GRINDING AND BLENDING

FIBRE DISCS

Suitable for

STEEL · STAINLESS STEEL

COLDSTEEL[®] Ceramic Fibre Disc



High-tech ceramic fibre disc with significantly more self-sharpening edges due its ultra-fine grit and crystal structure and a corresponding material removal rate that greatly exceeds that of conventional fibre discs.

FEATURES

- **Top ceramic quality!**
- Ultra-fine grit and crystal structures ensure significantly **more self-sharpening edges and greatly improved material removal.**
- **Self-sharpening ceramic grit.**
- The finer grinding results on the workpiece surface **reduces the frequent necessity of reworking** the piece with finer grits.
- Even in the coarse grit range, at a high rate of material removal, the size of the chip particles remains relatively small, preventing damage from the afterglow effect of large metal particles.
- The universal high-performance fibre disc with an especially great cooling agent content is easy on any drive motor.

Technical data:

Dimensions (mm)	Approved for (DIN EN 13743)	Packaging unit	Grit (K)	Article number
Ø 115 x 22.2	80 m/sec	25	36	82004
			60	82007
			80	82008
			120	82009
Ø 125 x 22.2	80 m/sec	25	24	82013
			36	82014
			60	82017
			80	82018
			120	82019
Ø 180 x 22.2	80 m/sec	25	24	82023
			36	82024
			60	82027
			80	82028
			120	82029



Suitable for

FIBRE DISCS**COLDSTEEL®
Backing Pad**

Specially developed heat-resistant backing pad for fibre discs. The ribs on the underside dissipate heat, effectively preventing heat build-up and discolouration.

**FEATURES**

- **Heat-resistant plastic** with a high fibre content for dimensional stability, even during continuous use.
- **Aluminium locking nut – no rust.**
- Aluminium alloy locking nuts prevent iron particle contamination of stainless steel when metals make contact.

Technical data:

Dimensions (mm)	Mount	Maximum speed (rpm)	Approved for (DIN EN 13743)	Packaging unit	Article number
Ø 113	M14 thread	13,000	80 m/sec	1	82001
Ø 123	M14 thread	12,000	80 m/sec	1	82011
Ø 173	M14 thread	8,500	80 m/sec	1	82021

5/8" threads upon request.

EISENBLÄTTER Ceramic self-sharpening process

The existing grinding force breaks off sintered microcrystals, continuously giving the grit new, sharp cutting edges.

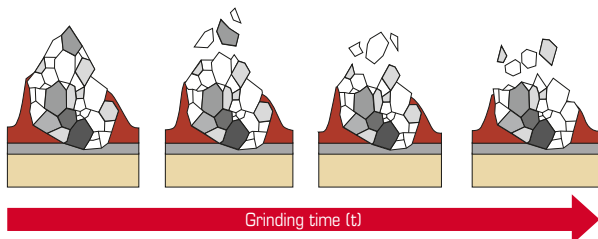

VARILEX[®] POLISHER HT **NEW**

DURABLE POWERHOUSE

Because of the high braking effect involved, polishing work is among the most challenging types of work for any drive motor. With its newly developed drive motor with planetary gear, Eisenblätler offers an unparalleled range of torque and performance. The distribution of power across three additional transmission gear wheels allow torques under full load that conventional single transmissions of comparable size cannot achieve.



POLISHER CAN BE DELIVERED AS A BATTERY-POWERED TOOL!

See pages 82-83

NEW 1,750-WATT MOTOR – EVEN MORE POWER

A refined motor with very high power density and a number of new features ensures completely new standards of torque, productivity, and service life.

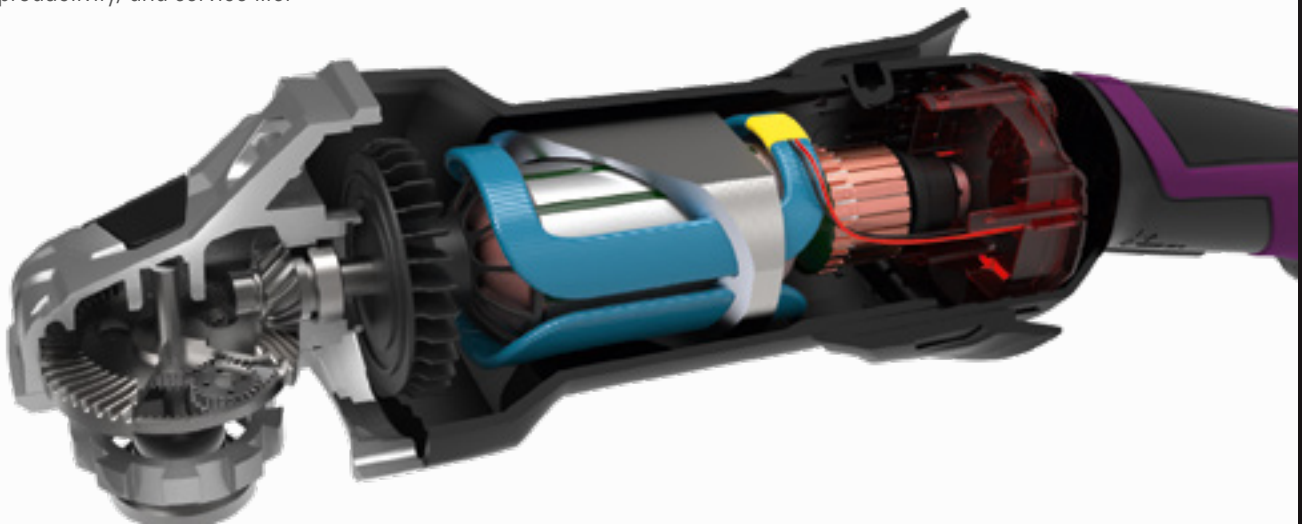



THE VARILEX® POLISHER HT IS DESIGNED FOR THE LONGEST SERVICE LIFE AND IS A PROFESSIONAL MACHINE FOR LONG-TERM USE!

Tip:

Ideal for finishing and fine grinding products – they can be found starting on page 87.

POWER TRANSMISSION WITH A PLANETARY GEAR

A high-quality planetary gear has been designed for grinding machines in the low speed range. It ensures wear-resistant power transmission with enormous additional torque.



VARILEX® POLISHER HT

DURABLE POWERHOUSE

OVERVIEW OF PRODUCT ADVANTAGES

- **Powerful motor (1,750 W) and new transmission mechanics** (high torque) for wear-resistant power transmission.
- Enormous power density despite the compact design: **Extremely powerful and robust one-hand polisher** (for disc up to Ø 180 mm) – made entirely in Germany.
- Eminently suitable for **cleaning, fine grinding, and polishing of stainless steel and non-ferrous metals**, for the FIX HOOK & LOOP system and, with an adapter, for the MINI FIX HOOK & LOOP system.
- **Balanced and vibration-damping handle** reduces strain on the user.
- The completely newly developed, patented **DUST PREVENT SYSTEM** effectively protects the interior of the motor from swarf and metal particles without impairing the cooling ventilation.
- **Infinitely adjustable speed from 820 to 3,000 rpm** with a tacho-generator for constant speed, even under load.
- Rubberised, **ultra-ergonomic shaft handle** ensures outstanding handling and sensitivity during work.
- **Elastic 3D ball handle** for optimum polishing handling and reduced strain on the user.

DUST PREVENT SYSTEM FROM EISENBLÄTTER

The new DUST PREVENT SYSTEM (patent pending) effectively provides protection from coarse swarf and metal particles without impairing the cooling ventilation. A protective cap effectively reduces dust entering the lateral ventilation grilles. Particles bounce off the protective cap. Fresh air intake is only from the air in the rear, which is largely free of particles.

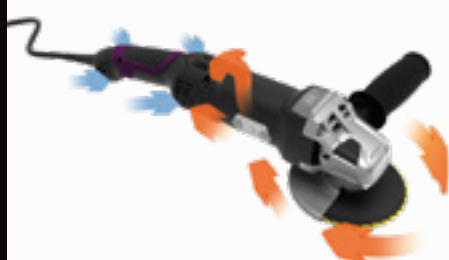

Without DUST PREVENT SYSTEM:
Coarse dust particles are taken into the ventilation grilles without any intervening protection.



With DUST PREVENT SYSTEM:
Coarse dust particles bounce off the protective cap, and air with few particles is taken in from the rear.



Alternative:
For particulate matter (with aluminium, etc.), we recommend, as an alternative to the DUST PREVENT SYSTEM, the particulate matter protection cap (see page 29).

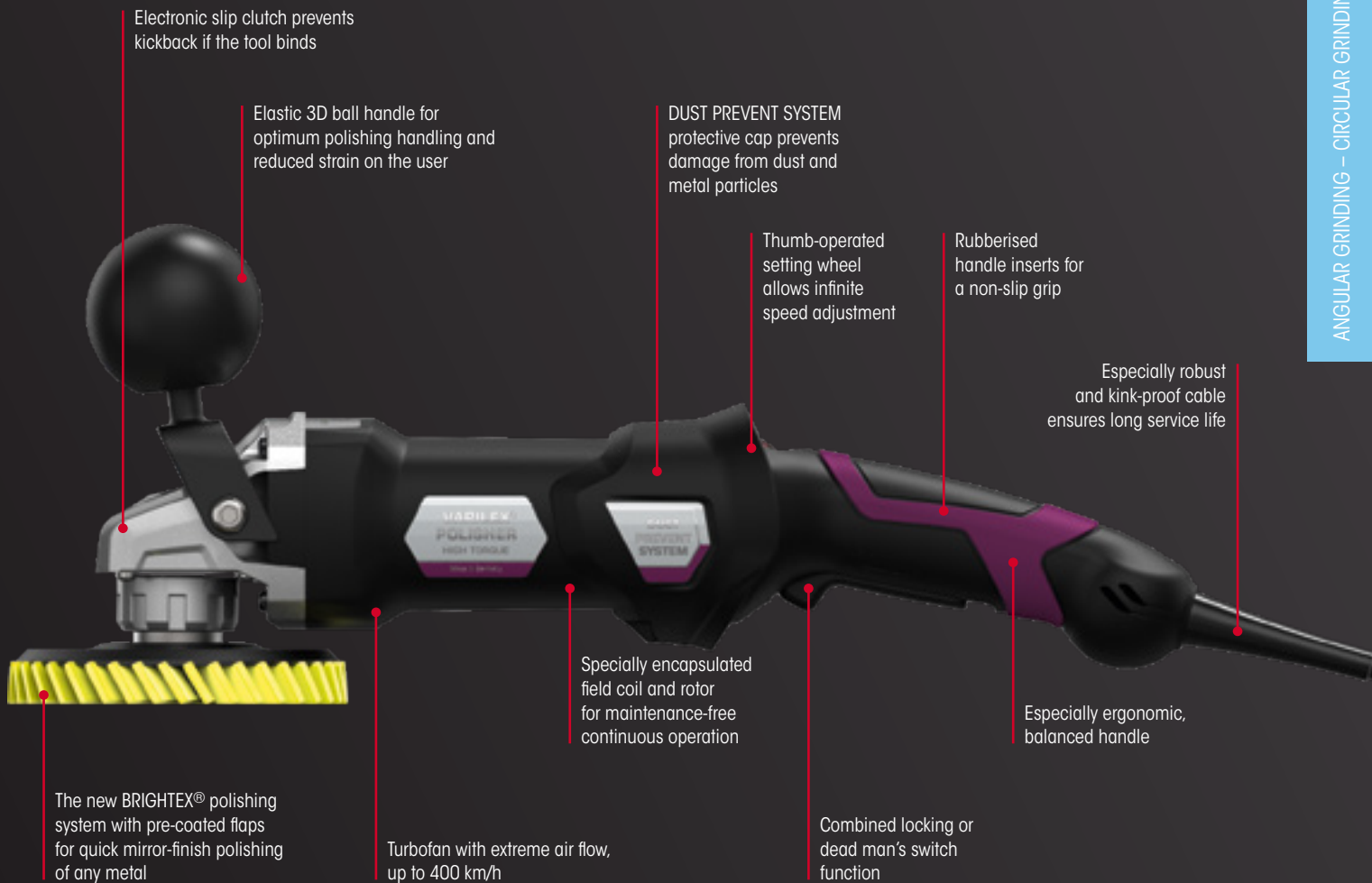

Technical data VARILEX® POLISHER HT basic set

Plug type	Cable type	Mains connection (V ~ Hz)	Power (W)	Mount	Speed (rpm)	Weight (kg)	Pkg. unit	Article number
EU (C+F)	Permanent connection	220-240 ~ 50-60	1,750	M14 thread	820-3,000	2.99	1	65051
CH (J)	Permanent connection	220-240 ~ 50-60	1,750	M14 thread	820-3,000	2.99	1	65051s
UK (G)	Permanent connection	110-240 ~ 50-60	1,750	M14 thread	820-3,000	2.99	1	65051a



- Set contents:**
- 1 VARILEX® POLISHER HT machine with 3D ball handle
 - 1 DUST PREVENT SYSTEM
 - 1 particulate matter protection cap
 - 1 robust, impact-resistant plastic case for machine and accessories
 - 1 support flange
 - 1 locking nut
 - 1 chuck key
 - 2 BRIGHTEX® FLAP polishing discs

Please Note: For the practical accessory set, see page 86.

VARILEX® POLISHER AKKU

NEW



Extremely high-performance one-handed polisher. The planetary gear and 18 V provides especially great torque and pulling power even with very long running times. Soft handle **is the first to allow** ideal handling in all working positions.

Ideal for the BRIGHTEX® mirror finish polishing system, finishing and fine grinding work and cleaning discs.

OVERVIEW OF PRODUCT ADVANTAGES

- **Powerful motor (18 V) and new transmission mechanics (high torque)** for wear-resistant power transmission. This is approx. 1,600 watts of power.
- Enormous power density despite the compact design: **Extremely powerful and robust one-hand polisher** – made entirely in Germany.
- **Balanced and vibration-damping 3D ball handle** reduces strain on the user.
- **Available for the first time with planetary gear**, giving it the power of a plug-in machine of ~1,600 watts.
- **Optimised speed of 1,600 rpm** with a tacho-generator and planetary gear for constant speed, even under load.
- Eminently suitable for **cleaning, fine grinding, and polishing of stainless steel and non-ferrous metals**, for the FIX HOOK & LOOP system and, with an adapter, for the MINI FIX HOOK & LOOP system.

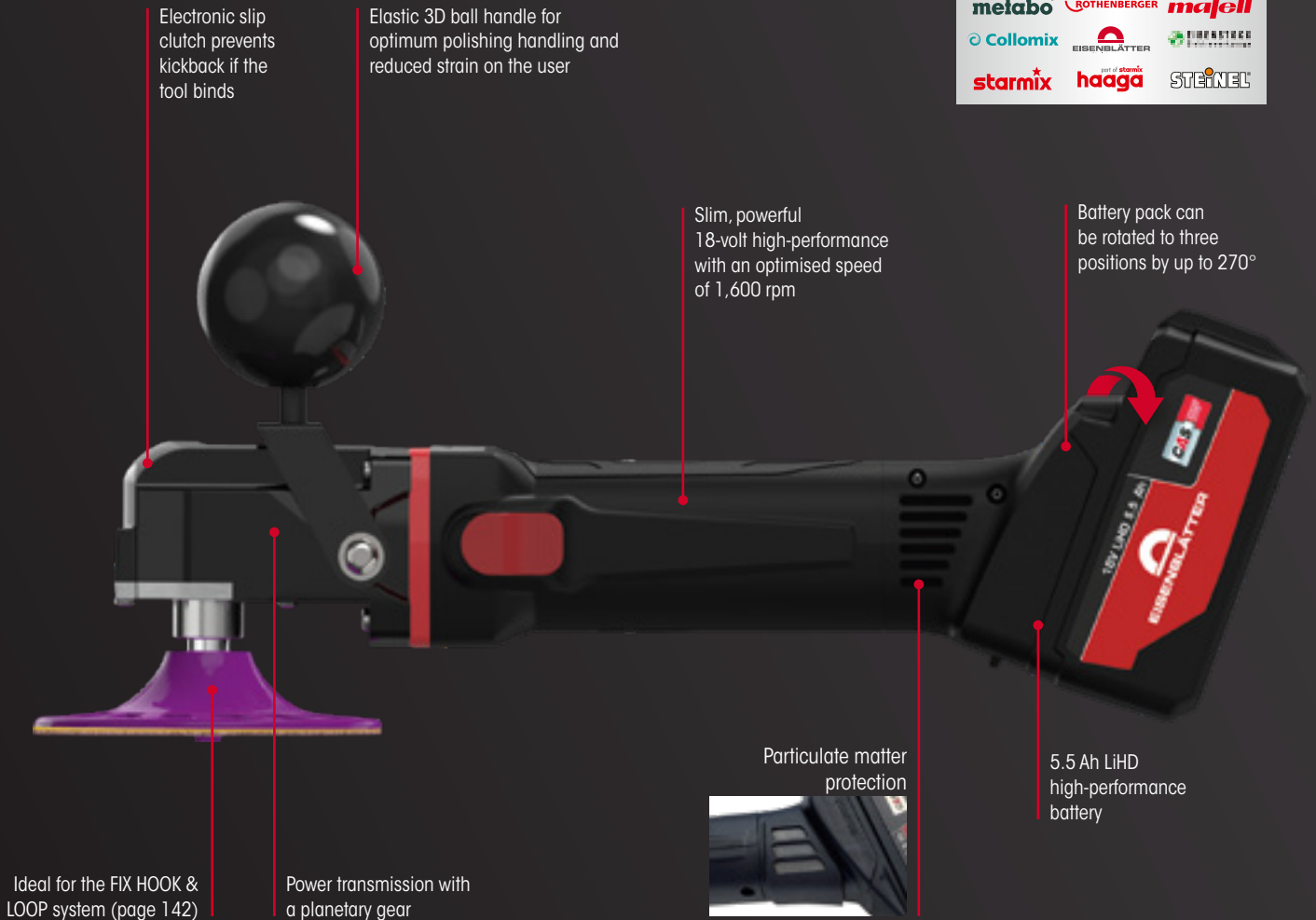



Technical data VARILEX® POLISHER AKKU basic set

Plug type	Cable type	Mains connection (V - Hz)	Power (V)	Mount	Speed (rpm)	Weight (kg)	Pkg. unit	Article number
EU (C+F)	Permanent connection	220-240 - 50-60	18	M14 thread	1,600	2.1	1	65061



- Set contents:**
- 1 VARILEX® POLISHER AKKU machine with 3D ball handle
 - 1 robust, impact-resistant plastic case for machine and accessories
 - 1 particulate matter protection battery
 - 2 18-volt LIHD batteries with 5.5 Ah capacity
 - 1 high-speed charging device, 220-240 volts
 - 1 support flange
 - 1 locking nut
 - 1 chuck key
 - 2 BRIGHTEX® FLAP polishing discs

Please Note: For the practical accessory set, see page 86.

POWER TOOLS

CORDLESS ALLIANCE SYSTEM

Suitable for

ALL CORDLESS ALLIANCE BATTERIES



High-speed Charging Device

NEW



For quick charging of all sliding-fit Li-ion and LiHD battery packs from 14.4 to 36 volts.

FEATURES

- **Patented "AIR COOLED" charging technology:** Batteries are cooled during charging for a much shorter charging time.
- High charging current ensures that the **battery packs are charged quickly.**
- Very **low stand-by power consumption.**
- Maximum charging current: 6.5 A.
- **Process-controlled charge management** for gentle charging and the greatest possible number of charging cycles.
- One charger for charging all battery packs from our CAS partner: www.cordless-alliance-system.de

Technical data:

Plug type	Cable type	Mains connection (V ~ Hz)	Maximum charging current (A)	Pkg. unit	Article number
EU (C+F)	Permanent connection	220-240 ~ 50-60	6.5	1	50474

Suitable for

ALL CORDLESS ALLIANCE SYSTEM DEVICES



5.5/8.0 Ah Battery

NEW



18 volts, LiHD technology

Powerful high-tech 18-volt battery (LiHD) for all battery-powered tools in the CAS group.

Technical data:

Article	Power (V)	Battery capacity (Ah)	Suitable for	Weight (kg)	Pkg. unit	Article number
5.5 Ah CAS battery	18	5.5	CAS devices	0.89	1	50463
8.0 Ah CAS battery	18	8.0	CAS devices	0.98	1	50473



Suitable for

VARILEX® POLISHER HT · VARILEX® POLISHER AKKU

NEW

VARILEX® POLISHER Accessory Set



This accessory set is the ideal addition to the VARILEX® POLISHER. Whether you want to smooth a weld seam or need a perfect mirror finish, this set provides everything you need, including surface cleaning and sealing agent. All packed neatly in a robust, impact-resistant plastic case.

Technical data:

Function	Can be used with:	Pkg. unit	Article number
Fine grinding to a perfect mirror finish	VARILEX® POLISHER HT · VARILEX® POLISHER AKKU	1	65052

Contents:

- | | | |
|---|--|-------------------------------|
| 1 plastic case | 2 FIX HOOK & LOOP AluPolish, Ø 115 mm | 1 INOX PROTECT 50 ml |
| 3 Fleece Flap Soft, Ø 125 mm | 2 BRIGHTEX® mini pastes | 2 BRIGHTEX® microfibre cloths |
| 1 FIX HOOK & LOOP backing pad, Ø 115 mm | 1 BRILLIANCE Clean 50 ml | 1 BRIGHTEX® Softclean Powder |
| 4 FIX HOOK & LOOP Trizact™, Ø 115 mm | 1 Power Cleaner 50 ml | |
| 2 BRIGHTEX® FLAP polishing discs Ø 115 mm | 6 FIX HOOK & LOOP BRIGHTEX® polishing discs Ø 115 mm | |

THE IDEAL ADDITION FOR THESE EISENBLÄTTER MACHINES:

VARILEX® POLISHER HT p. 78

VARILEX® POLISHER AKKU p. 82



Suitable for

ALL METALS

MAGNUM[®] Poly Magic Wheel

The revolution for mirror-finish polishing in corners



Application:

- 1. Pre-polish** and level fine weld seams with the MAGNUM[®] Poly Magic Wheel, **A grit**.
- 2. Polish** to a flawless mirror finish with the MAGNUM[®] Poly Magic Wheel, **B grit**.

FEATURES

- For **fine grinding and mirror-finish polishing** in corners.
 - Saves lots of working time and **replaces expensive manual labour**, particularly in balustrade and hand-rail production, which often involves corner welds.
 - **Produces a flawless mirror finish in just two steps without polishing pastes or creams.**
 - Can be used on many variable-speed angle grinders/polishers.
 - Backing plate of specially developed food-grade, flexible plastic: **easy to trim and damps vibration.**
- New formulation:**
- Highly compressed fleece disc for **greatly extended service life.**
 - **Now it can also be used on flat surfaces.**
- Machine recommendation:**
- VARILEX[®] POLISHER page 78.

Technical data:

Dimensions (mm)	Ideal speed (rpm)	Maximum speed (rpm)	Material thickness (mm)	Backing plate	Ideal for	Application	Pkg. unit	Article number
Ø 165 x 22.2	3,000-4,000	5,700	6	special flexible plastic	variable-speed angle grinders	Pre-polishing (A)	5	96720
						Polishing (B)	5	96721



NEW

Suitable for

ALL METALS · WOOD · HARD PLASTICS

MAGNUM® DecoFinish

New compact fleece with sensational, revolutionary properties



The open-pore design achieves especially fine, decorative results on all metals, hard plastics, and wood. Fine weld seams, spot welds, and deep scratches can be directly removed at the same time, depending on contact pressure. The especially fine finish allows an immediate perfect mirror finish with polishing discs such as those from the BRIGHTEX® polishing system if needed. This avoids time-consuming intermediate grinding and polishing steps. Even paint layers with filler on vehicle body parts can be ground down to bare metal. This metal is given a top finish and can immediately be re-painted.

With MAGNUM® DecoFinish, rust and oxide layers are no hindrance to a perfect final finish, either. This new compact fleece can be used for a variety of applications. It is extremely tough and durable, does not clog pores, and has damping, cooling properties that allow perfect workpiece adaptation and soft grinding transitions.

The MAGNUM® DecoFinish is certainly one of the most modern compact fleece designs on the global market.

FEATURES

- **Outstanding for all metals** (stainless steel, steel, non-ferrous metals, etc.) and for hard plastic and wood.
- **Achieves the finest grinding results while smoothing scratches, minor weld seams, and spot welds.**
- **Removes paint, rust, and oxide perfectly while achieving a top quality finish.**
- Open-pore, tough **compact fleece with a long service life** (does not clog pores!).
- Cool grinding behaviour **prevents discolouration.**
- Elastic properties ensure **perfect workpiece adaptation.**
- **Integrated M14 threads** ensure simple, fast, convenient disc change.
- Elastic, **high-tech natural fibre compound backing plate** is easy on the environment and the user (CO₂-neutral), fully trimmable so that the entire disc can be used, damps noise and vibration.



Technical data MAGNUM® DecoFinish

Dimensions (mm)	Ideal speed (rpm)	Maximum speed (rpm)	Approved for	Material thickness (mm)	Backing plate	Ideal for	Pkg. unit	Article number
125 mm x M14	2,000-4,000	4,500	30 m/sec	13	Natural fibre	variable-speed angle grinders	5	96725



Application examples:

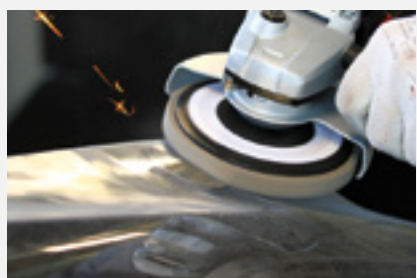

Removes scratches and small spot welds and seams all at the same time.



Ideal for pre-polishing.



Viscoelastic properties ensure perfect work-piece adaptation.



Subsequent mirror finish polish with the BRIGHTEX® polishing system (Berry + Sun). See the polishing section starting on page 96.



Removes paint while achieving a surface finish.

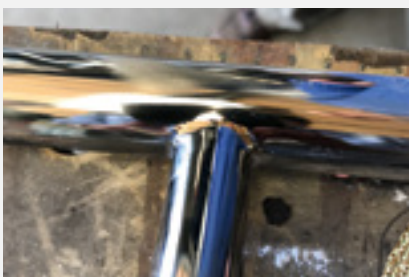

Result: raw to perfect mirror finish in two to three steps – also ideal for round pipes.

Elastic, **high-tech natural fibre compound backing plate** is easy on the environment and the user (CO₂-neutral), fully trimmable so that the entire disc can be used, damps noise and vibration

Full-surface, open-pore special fleece
Outstanding for all metals

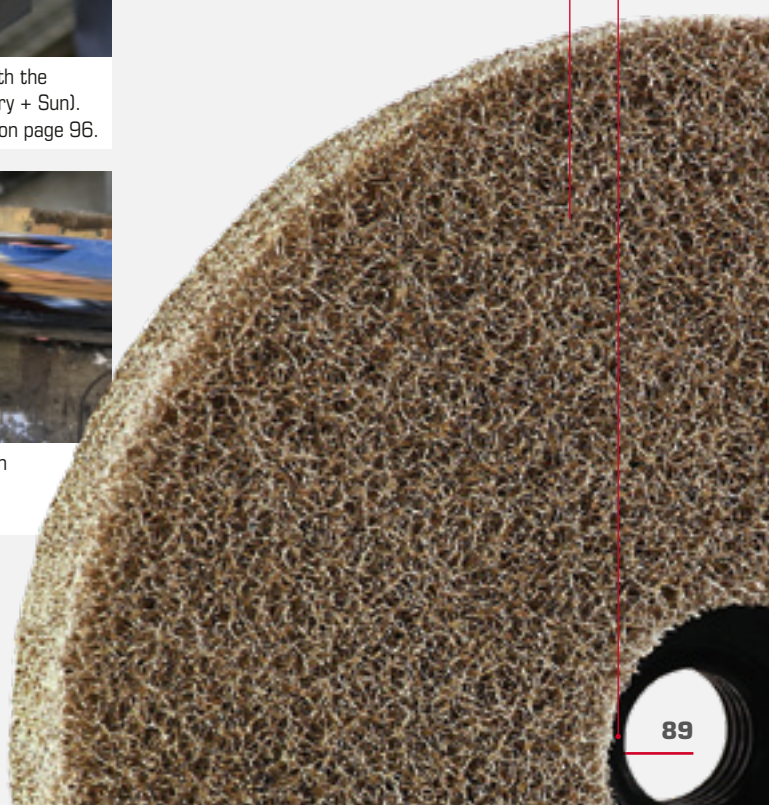

Suitable for

ALL METALS · WOOD

**ONLY FROM EISENBLÄTTER:
1FOR2 extra-coarse grit***

TRIMFIX® Fleece Flap

Highly elastic SC fleece flap disc – ideal fine machining of weld seams



FEATURES

- **Highly flexible, damping fleece flap disc** with low overall height.
- High-quality surface conditioning (SC) fleece material for an **extremely long service life**.
- Ideal for subsequent high-gloss and mirror-finish polishing of stainless steel.
- Large effective contact surface area **for greater heat dissipation**.
- **Ideal for rounding off internal edges.**
- In all grit grades from fine grinding to matt sheen.
- Elastic, **high-tech natural fibre compound backing plate** is easy on the environment and the user (CO₂-neutral), fully trimmable so that the entire disc can be used, damps noise and vibration.
- * **The 1FOR2 extra-coarse (green) grit's ceramic grit content allows** easy removal of thin weld seams and spot welds.

Technical data:

Dimensions (mm)	Ideal speed (rpm)	Maximum speed (rpm)	Approved for (DIN EN 13743)	Ideal for	Backing plate	Pkg. unit	Grit (fleece)	Grit (K)	Colour (fleece)	Article number
Ø 125 x 22.2	2,000-5,000	12,200	80 m/sec	variable-speed angle grinders	Natural fibre	10	1FOR2 extra-coarse	40	green	96740
							coarse	80	brown	96741
							medium	180	red	96742
							fine	280	blue	96743



For deburring, fine grinding, pipe finishing, TIG, weld grinding, and intermediate grinding

The 1FOR2 extra-coarse (green) grit allows removal of thin weld seams and spot welds.

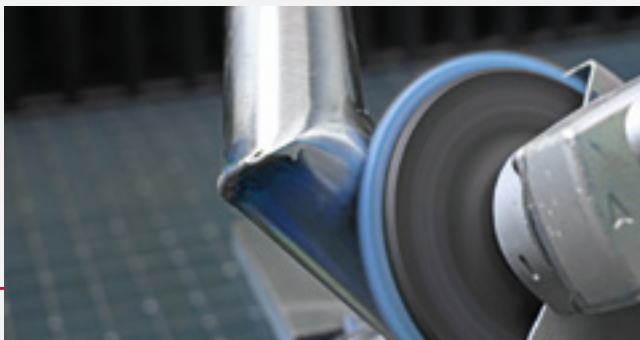

Suitable for

ALL METALS · WOOD

**ONLY FROM EISENBLÄTTER:
1FOR2 extra-coarse grit***

NEW

TRIMFIX® Fleece Flap Soft



The new kind of fine grinding

Highly elastic SC fleece flap disc with upright rubber flaps for fine grinding of **straight and shaped components**. In a “soft” flap geometry, a number of fleece flaps are applied to a natural-fibre compound backing plate. The **spring effect** of the flap packages allows **very soft grinding transitions** that often require no rework. This allows the user to **determine how much contact pressure to exert**, and thus whether material is to be removed or, at low pressure, the surface is merely to be brightened or fine deburring to be performed.

FEATURES

- **Highly flexible, elastic fleece flap disc** with upright flaps.
- High quantities of surface conditioning (SC) fleece material for **an extremely long service life**.
- Ideal for subsequent **high-gloss and mirror-finish polishing** of stainless steel.
- For deburring, fine grinding, pipe finishing, TIG, weld grinding and intermediate grinding, especially for shaped or uneven workpieces **with perfect workpiece adaptation**.
- **Ideal for rounding off internal edges**.
- Large effective contact surface area **for greater heat dissipation**.
- Elastic, **high-tech natural fibre compound backing plate** is easy on the environment and the user (CO₂-neutral), fully trimmable so that the entire disc can be used, damps noise and vibration.
- * **The 1FOR2 extra-coarse (green) grit's ceramic grit content allows** easy removal of thin weld **seams and spot welds**.

Technical data:

Dimensions (mm)	Ideal speed (rpm)	Maximum speed (rpm)	Approved for (DIN EN 13743)	Ideal for	Backing plate	Pkg. unit	Grit (fleece)	Grit (K)	Colour (fleece)	Article number
Ø 125 x 22.2	2,000-4,500	5,000	50 m/sec	variable-speed angle grinders	Natural fibre	10	1FOR2 extra-coarse	40	green	96740s
							coarse	80	brown	96741s
							medium	180	red	96742s
							fine	280	blue	96743s

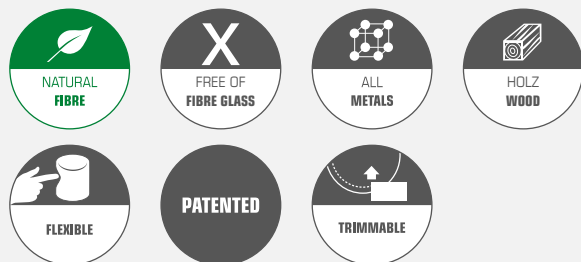

Suitable for

ALL METALS · WOOD · HARD PLASTICS

MAGNUM[®] Fleece Top

Versatile fleece disc manufactured from foamed, compressed grinding fleece for fine finishes

For metalworking jobs such as grinding, fine grinding, smoothing and polishing and removing oxides, scratches, rust, burrs and paint. Also cleans and smooths wood and plastics.



FEATURES

- **Up to 8 times the service life** of conventional fleece discs.
- The special **self-cleaning fleece mixture prevents clogging and smearing.**
- Replaces wire brushes, sandpaper and rubber grinding wheels.
- Also ideal for **cleaning and smoothing metal, wood, and plastic.**
- **Consistently clean grinding results.**
- **Perfect for smoothing tool surfaces.**
- Backing plate of specially developed flexible, food-grade plastic: **easy to trim, damps vibration and completely free of glass fibre.**
- Its 30-mm-wide silicon carbide fleece ring **significantly extends its service life!**



Technical data MAGNUM® Fleece Top

Dimensions (mm)	Ideal speed (rpm)	Maximum speed (rpm)	Material thickness (mm)	Backing plate	Ideal for	Packaging unit	Grit (K)	Article number
Ø 115 x 22.2	2,000-5,000	8,000	15	special flexible plastic	variable-speed angle grinders	5	80	96710
							180	96711
							280	96712
							400	96713
							600	96714
							900	96715

Roughness depth values:

Average roughness depth for stainless steel	80	180	280	400	600	900
Rz in µ	6.10 µ	4.16 µ	2.78 µ	2.74 µ	2.26 µ	1.66 µ

Average roughness depth for aluminium	80	180	280	400	600	900
Rz in µ	9.26 µ	5.63 µ	3.85 µ	3.78 µ	2.68 µ	2.58 µ

Rz = average roughness depth value

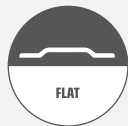

Application examples:



Stainless steel: Cleaning, removing minor scratches



Steel: Fine grinding, deburring, rust removal



Aluminium: Cleaning, fine grinding



Wood: Smoothing wood fibre

Please Note: The existing paint can be removed easily with Eisenblätter's CLEAN products.

The special self-cleaning fleece mixture prevents clogging and smearing

Perfect for smoothing tool surfaces



NEW

Suitable for

STEEL · STAINLESS STEEL · NON-FERROUS METALS

MAGNUM® Top Mix/ Top Mix Strong

Combination fleece disc – complete 2 operations at once, greater material removal with fine grinding results

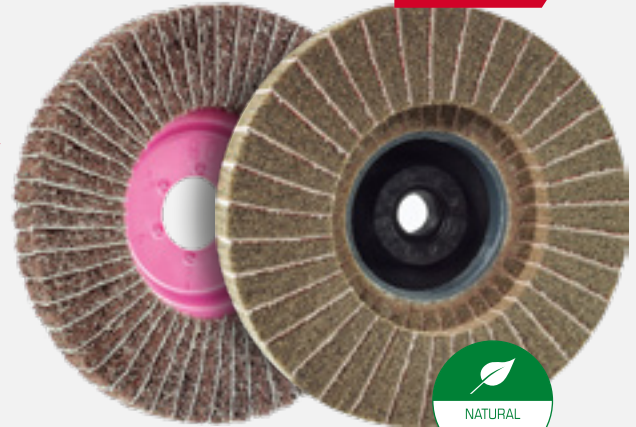

FEATURES

MAGNUM® Top Mix

- Intermediate A/O grit layers make these discs **significantly more aggressive than conventional fleece** discs.
- The coordinated combination of abrasive flaps alternating with compressed fleece produces a **much better grinding performance, longer service life, and fine grinding results.**
- For **preparatory grinding and fine grinding of spot welds and deep scratches** on stainless steel, steel and non-ferrous metals; also great for finely deburring perforated sheet metal and reworking corners.
- Backing plate of specially developed flexible, food-grade plastic: **easy to trim, damps vibration, and completely free of glass fibre.**

NEW: MAGNUM® Top Mix Strong

- With ceramic grit content for much higher material removal and fine grinding results.
- The highly compressed fleece material has many times the service life of conventional combination fleece discs.
- Elastic, **high-tech natural fibre compound backing plate** is easy on the environment and the user (CO₂-neutral), fully trimmable so that the entire disc can be used, damps noise and vibration.
- **Integrated M14 threads** ensure simple, fast, convenient disc change.

Technical data:

Product	Dimensions (mm)	Ideal speed (rpm)	Maximum speed (rpm)	Material thickness (mm)	Backing plate	Ideal for	Pkg. unit	Grit (K)	Article number
Top Mix	Ø 125 x 22.2	2,000-5,000	6,000	15	special flexible plastic	variable-speed angle grinders	5	80/100	96705
Top Mix Strong	Ø 125 x M14	2,000-5,000	6,000	15	Natural fibre	variable-speed angle grinders	5	60/80	96703

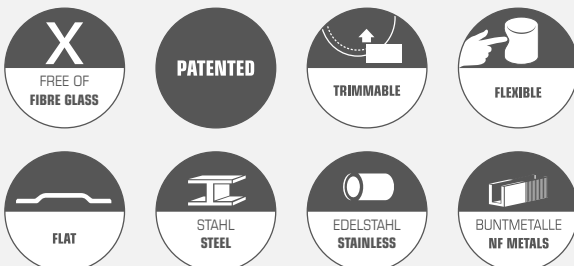

Suitable for

STEEL · STAINLESS STEEL

Trizact™ Disc

New type of abrasive fabric with pyramid-shaped grit structure. Saves multiple operations. Very fine results with high material removal.

Available for these quick-change systems:



FIX HOOK & LOOP
MORE DETAILS ON P. 147



MINI FIX HOOK & LOOP
MORE DETAILS ON P. 125

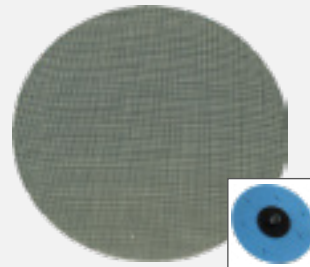

PINLOC
MORE DETAILS ON P. 132

Suitable for

STEEL · STAINLESS STEEL · NON-FERROUS METALS · WOOD · HARD PLASTICS

SC Fleece Disc

Ideally suited to deburring, fine grinding, and removing minor scratches and oxide layers.

Available for these quick-change systems:



FIX HOOK & LOOP
MORE DETAILS ON P. 146

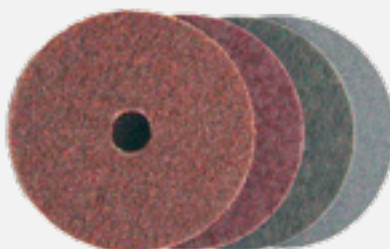

MINI FIX HOOK & LOOP
MORE DETAILS ON P. 125

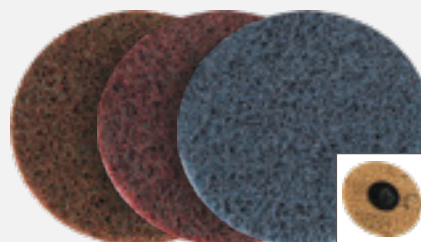

PINLOC
MORE DETAILS ON P. 133

Suitable for

ALUMINIUM · NON-FERROUS METALS

FIX HOOK & LOOP AluPolish Disc

Soft nylon fleece material for fine grinding (pre-polishing) aluminium and soft metals to a perfect mirror finish.

YOU CAN FIND MORE DETAILS ON PAGE 145.



NEW

Suitable for

ALL METALS

BRIGHTEX® FLAP BERRY (pre-polishing)



Flexibly fanned polishing disc of polishing fleece **pre-impregnated with BRIGHTEX® Berry** polishing paste, forms itself very well to flat and shaped surfaces and polishes in a single work step, even when there are still oxide layers. **Step 1: High-gloss!**

FEATURES

- For applying a rapid high-gloss polish to all metals.
- For reconditioning surfaces which are mirror polished mechanically.
- Ideal for use with polishing machines and hand-held polishing tools.
- Completely new high-tech paste formulation.
- Elastic, **high-tech natural fibre compound backing plate** is easy on the environment and the user (CO₂-neutral), fully trimmable so that the entire disc can be used, damps noise and vibration.
- Pre-polish and main polish in one – save on additional operations.
- For immediate use without additional pastes and creams!
- Flaps can be topped up repeatedly with BRIGHTEX® hard paste (check grit!) (see page 98).
- For the best results, use **Eisenblätter care and cleaning products** for removing polish residues (BRIGHTEX® Softclean Powder, Power Cleaner).
- **Recommendation:** BRIGHTEX® FLAP SUN for the perfect main polish mirror finish.
- **Please Note:** After changing pastes, always remove the polish residue from the workpiece! As necessary, the backing can be rewetted with BRIGHTEX® pastes.

Technical data:

Dimensions (mm)	Version	Application	Ideal speed (rpm)	Maximum speed (rpm)	Backing	Packaging unit	Article number
Ø 115 x 22	Berry (pink)	High-gloss polishing	600-3,000	5,850	Natural fibre	5	96746
Ø 125 x 22				5,350			96748



Mirror-finish polishing (here, on bronze)

NEW

Suitable for

ALL METALS

BRIGHTEX® FLAP SUN (main polish)



Flexibly fanned polishing disc of polishing fleece **pre-impregnated with BRIGHTEX® Sun polishing paste**, forms itself very well to flat and shaped surfaces and removes even the finest smears and any clouding very quickly.

Step 2: A mirror finish that's almost like chrome plating!

FEATURES

- For a final high-gloss shine on polished metals.
- For reconditioning high-gloss surfaces which have been polished mechanically.
- Ideal for use with polishing machines and hand-held polishing tools.
- For the best results, use **Eisenblätter care and cleaning products** for removing polish residues (BRIGHTEX® Softclean Powder, Power Cleaner).
- Elastic, **high-tech natural fibre compound backing plate** is easy on the environment and the user (CO₂-neutral), fully trimmable so that the entire disc can be used, damps noise and vibration.
- Completely new high-tech paste formulation.
- **A mirror finish that's almost like chrome plating – perfect finish.**
- For removing any residual clouding and smears from all metals.
- Flaps can be topped up repeatedly with BRIGHTEX® hard paste (check grit!) (see page 98).
- **Recommendation:** BRIGHTEX® FLAP BERRY for quick pre-polishing.
- **Please Note:** After changing pastes, always remove the polish residue from the workpiece! As necessary, the backing can be rewetted with BRIGHTEX® pastes.

Technical data:

Dimensions (mm)	Version	Application	Ideal speed (rpm)	Maximum speed (rpm)	Backing	Packaging unit	Article number
Ø 115 x 22	Sun (yellow)	Mirror-finish polishing	600-3,000	5,850	Natural fibre	5	96747
Ø 125 x 22				5,350			96749



Mirror-finish polishing (here, on stainless steel)

Suitable for

ALL METALS

NEW FORMULATION

BRIGHTEX® High-performance Polishing Pastes

The fastest way to a mirror finish

For the first time, the **pre-polishing and main polishing steps can be completed with just one paste (BRIGHTEX® Berry)**! This has been made possible by a completely new formulation. For instance, stainless steel can be polished to a mirror finish in only a few moments. This saves **several working steps**. The yellow **BRIGHTEX® Sun** paste creates an **even brighter high gloss shine** – almost as if it's **chrome plated**. Both pastes can be used on SuperPolish discs and belts and on felt discs, belts, and sleeves. The pastes are applied to the polishing disc, belt, or sleeve while it is running at a low speed so that it is completely covered. This process can be repeated several times. The pastes can also be used for the new BRIGHTEX® polishing system (pre-impregnated polishing discs, belts, and sleeves) to “top up” the polishing fleeces as required.



FEATURES

Step 1: BRIGHTEX® Berry (pre-polishing):

- For applying a rapid high-gloss polish to all metals.
- Pre-polish and main polish in one – save on additional working steps.

Step 2: BRIGHTEX® Sun (main polish):

- A mirror finish that's almost like chrome plating – perfect finish.
- For a final high-gloss shine on polished metals.
- For removing any residual clouding and smears from all metals.
- **Please Note:**
After changing pastes, always remove the polish residue from the workpiece!

- For reconditioning high-gloss surfaces which have been polished mechanically.
- For use with felt, cotton, fleece discs, wheels, sleeves, belts, etc.
- Ideal for use with polishing machines and hand-held polishing tools (POLY-PTX®).
- For the best results, use Eisenblätter care and cleaning products to remove polish residues (BRIGHTEX® Softclean Powder, Power Cleaner).
- Completely new high-tech paste formulation for metals.

Technical data:

Paste	Contents (g)	Application	Packaging unit	Article number
BRIGHTEX® Berry pre- and main polish (pink)	about 1,100	High-gloss polishing	1	40025
BRIGHTEX® Berry mini paste (pink)	about 140	High-gloss polishing	1	40025m
BRIGHTEX® Sun post-polishing paste (yellow)	about 1,300	Mirror-finish polishing	1	40026
BRIGHTEX® Sun mini paste (yellow)	about 140	Mirror-finish polishing	1	40026m

Suitable for

ALL METALS

BRIGHTEX® Softclean Powder

A **new**, much improved **cleaning powder** removes all cream and paste residue after every polish, giving all metals a polished, completely scratch-free shine. Simply apply a little using the shaker, as you would powdered sugar, and wipe it off with a **clean microfibre cloth** without applying any pressure. The powder consists of **ultra-fine micro-particles** with a large surface area for the **best possible absorbency**.



Technical data:

Packaging	Contents (g)	Packaging unit	Article number
Resealable bag	about 1,000	1	40028
Aluminium shaker	about 200	1	40029

Suitable for

ALL MATERIALS

BRIGHTEX® Microfibre Cloths



Much improved, **ultra-soft microfibre cloth**, free of seams for completely **scratch-free cleaning** of **stainless steel surfaces** and other **decorative metals**. Particularly soft and absorbent. Can be washed repeatedly.

Technical data:

Dimensions (mm)	Quality	Packaging unit	Article number
400 x 400	360 g/m ²	5	40031



Suitable for

ALL METALS

Power Cleaner

Universal cleaner in its most environmentally-friendly form

Clean and preserve – especially for the removal of grease-based polish residue (BRIGHTEX® pastes).

YOU CAN FIND MORE DETAILS ON PAGE 276.



NEW

Technical data:

Packaging	Contents	Packaging unit	Article number
Spray bottle	50 ml	1	40057
	500 ml	1	40055
Can (including spray bottle)	5 litres	1	40056

Suitable for

ALL METALS

Polishing Pastes (Classic)

Mirror-finish polishing for all metals (including aluminium).

White for pre-polishing, blue for final polish.

Technical data:

Paste	Contents (g)	Pkg. unit	Article number
Pre-polishing paste (white)	about 650	1	40013
Polishing paste (blue)	about 650	1	40014
White and blue mini paste	approx. 120 (60 each)	1	40009



Suitable for

ALL METALS

Pink Polishing Cream

For final polishing, with Classic polishing pastes, for example, it produces a flawless mirror finish on all metals when applied with SuperPolish, felt, and polishing rings. Brings a quick shine – also suitable for manual application with polishing cloths. Ideal for moulded parts as well.

Technical data:

Packaging	Contents	Packaging unit	Article number
Can	about 1,000 g	1	40015
Mini-tube	approx. 60 ml	1	40015t



Suitable for

ALL METALS

Berry & Sun BRIGHTEX® Discs

Polishing material that is already impregnated with BRIGHTEX® polishing paste removes the time-consuming hassle of applying pastes and creams to give untreated metal a shadow-free mirror finish.

Available for these quick-change systems:



FIX HOOK & LOOP
MORE DETAILS ON P. 148



MINI FIX HOOK & LOOP
MORE DETAILS ON P. 126

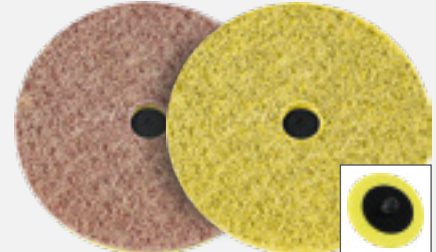

PINLOC
MORE DETAILS ON P. 134

Suitable for

ALL METALS

SuperPolish Disc

Revolutionary special fleece. Used with polishing pastes and creams for a shiny mirror finish which, especially on stainless steel and non-ferrous metals, leaves no smears or shadows. SuperPolish is absorbent and does not smear up.

Available for these quick-change systems:

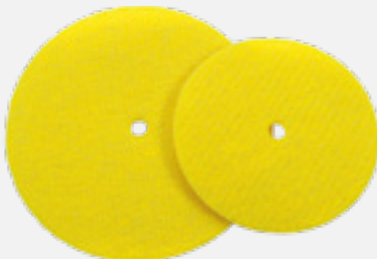

FIX HOOK & LOOP
MORE DETAILS ON P. 149



MINI FIX HOOK & LOOP
MORE DETAILS ON P. 127

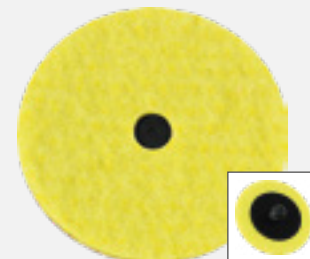

PINLOC
MORE DETAILS ON P. 135

Suitable for

ALUMINIUM · NON-FERROUS METALS · HARD PLASTICS

Felt Disc

For rapid mirror finish using polishing pastes and creams that leave no scratches or smears.

Available for these quick-change systems:



FIX HOOK & LOOP
MORE DETAILS ON P. 149



MINI FIX HOOK & LOOP
MORE DETAILS ON P. 127

NEW

Suitable for

ALL METALS · WOOD · BRICK

MAGNUM® CLEAN-MIX

When things need to move along

Newly designed cleaning wheel with intermediate abrasive flap layers. For an enhanced cleaning effect and longer disc service life. Open, elastic CLEAN material pores prevent the grinding disc from clogging and achieve a sand-blast-like effect on metal.



FEATURES

- **Nylon fibre “Clean” material containing grit**, with intermediate ceramic abrasive cloth layers **for greater material removal and much longer service life, with consistent grinding results.**
- Ideal for cleaning and freshening up wood surfaces, removing shell limestone from ship substructures, etc.
- The disc’s external diameter is trimmable. No fibre glass components were used.
- The intermediate abrasive flap layers, tailored to the CLEAN material, ensure **uniform wear and therefore consistent grinding results.**
- **The quickest way to remove scales, rust, burrs, etc. from metals.**
- **Quick cleaning and renewing of wooden surfaces.**
- Elastic, **high-tech natural fibre compound backing plate** is easy on the environment and the user (CO₂-neutral), fully trimmable so that the entire disc can be used, damps noise and vibration, with practical M14 threads, for fixing discs quickly without tools.
- The **integrated M14 threads** mean that no locking nut is necessary – no risk of contamination from the workpiece touching the steel locking nut.

Technical data:

Dimensions (mm)	Ideal speed rpm	Maximum speed rpm	Approved for	Material thickness (mm)	Backing plate	Pkg. unit	Ideal for	Grit (K)	Article number
125 mm x M14	2,000-4,500	4,500	30 m/sec	about 15	Natural fibre	5	variable-speed angle grinders	80	96704

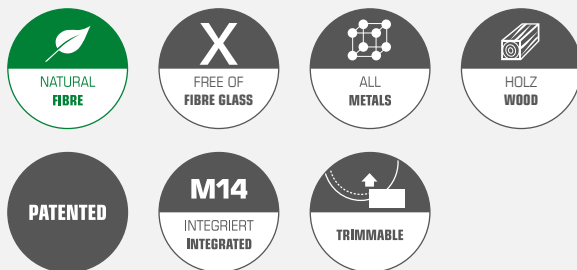

NEW



Suitable for

ALL METALS · WOOD

MAGNUM[®] CLEAN-PLUS

Clean more in the same amount of time

The open-pore hard nylon cloth with grinding grit fits well to all workpieces, does not smear up, and leaves behind a bright surface like that expected from sand-blasting, without changing dimensional tolerance (even thin sheet metal can be easily machined).

FEATURES

- Nylon fleece combined with abrasive cloth, **elastic so that it adapts better to the workpiece.**
- Large-surface cloth content for **much longer service life.**
- Cleans all materials, such as metals, stone, plastics, and wood (boards and planks), pore-deep.
- **Effect is similar to that of sand-blasting, does not damage the basis.**
- Also removes rust, oxide, paint, Teroson, and much more.
- The sophisticated backing plate allows large-area application of hard fleece components – for less load and thus more than **50% longer service life.**
- **The longest possible service life** for cleaning and removing paint, rust, oxides, etc.
- Elastic, **high-tech natural fibre compound backing plate** is easy on the environment and the user (CO₂-neutral), fully trimmable so that the entire disc can be used, damps noise and vibration, with practical M14 threads, for fixing discs quickly without tools.
- The **integrated M14 threads** greatly simplify disc change, and no locking nut is necessary – no risk of contamination from the workpiece touching the steel locking nut.
- **Please Note:** **Replaces** (with great service life and binding technology advantages) **MAGNUM[®] CLEAN.**

Technical data:

Dimensions (mm)	Ideal speed (rpm)	Maximum speed (rpm)	Approved for	Material thickness (mm)	Backing plate	Packaging unit	Ideal for	Article number
Ø 125 x M14	2,000-4,500	4,500	30 m/sec	about 15	Natural fibre	5	variable-speed angle grinders	96706



NEW

Suitable for

ALL METALS · WOOD

MAGNUM[®] CLEAN Strong

When cleaning becomes a challenge



Removes the coarsest dirt and crusting from all surfaces and metals (such as vehicle undercarriages and ship subframes). Cleans cement or casting compound residue from bricks and ceramic tiles.

FEATURES

- With ceramic grit-impregnated hard nylon fleece for challenging cleaning and rust, oxide, and paint removal from metals, stone, brick, plastics, and wood. **Also ideal for the construction industry.**
- Much longer **service life than “pure black Clean material”, resistant to acids, oils, and grease.**
- The fleece covers almost the entire surface for extreme durability.
- **Extremely long service life** guaranteed due to application on a larger surface (more than 50% larger) than narrow, conventional cleaning rings!
- **Most efficient material removal and service life for cleaning and removing paint, rust, and oxides,** removing shell limestone from ship substructures, etc.
- Elastic, **high-tech natural fibre compound backing plate** is easy on the environment and the user (CO₂-neutral), fully trimmable so that the entire disc can be used, damps noise and vibration, with practical M14 threads, for fixing discs quickly without tools.
- The **integrated M14 threads** mean that no locking nut is necessary – no risk of contamination from the workpiece touching the steel locking nut.

Technical data:

Dimensions (mm)	Ideal speed (rpm)	Maximum speed (rpm)	Approved for	Material thickness (mm)	Backing plate	Packaging unit	Ideal for	Article number
Ø 125 x M14	2,000-4,500	4,500	30 m/sec	about 15	Natural fibre	5	variable-speed angle grinders	96707

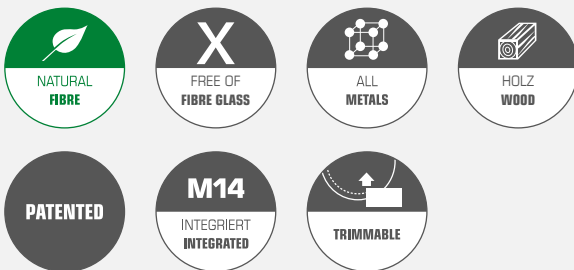

NEW



Suitable for

STAINLESS STEEL

MAGNUM[®] STAINLESS-CLEAN

Stainless steel cleaning – looking its best

Cleans and smooths stainless steel or steel weld seam surfaces quickly, harmonises and smooths weld seams, and gives them the same perfect, high-level gloss – even in corners.

FEATURES

- Special fleece fabric impregnated with ceramic grit for stainless steel machining.
- Developed for cleaning and smoothing stainless steel weld seams and surfaces. Removes even minor spot welds, discolouration, and deep scratches.
- Full-surface fabric allows **exceptionally long service life**.
- **Extremely long service life** guaranteed due to application on a larger surface (more than 50% larger) than narrow, conventional cleaning rings!
- **Cleans and smooths stainless steel** weld seams and removes spot welds, discolouration, and scratches.
- Elastic, **high-tech natural fibre compound backing plate** is easy on the environment and the user (CO₂-neutral), fully trimmable so that the entire disc can be used, damps noise and vibration, with practical M14 threads, for fixing discs quickly without tools.
- The **integrated M14 threads** mean that no locking nut is necessary – no risk of contamination from the workpiece touching the steel locking nut.

Technical data:

Dimensions (mm)	Ideal speed (rpm)	Maximum speed (rpm)	Approved for	Material thickness (mm)	Backing plate	Packaging unit	Ideal for	Article number
Ø 125 x M14	2,000-4,500	4,500	30 m/sec	about 15	Natural fibre	5	variable-speed angle grinders	96708



NATURAL
FIBRE

X

FREE OF
FIBRE GLASS



EDELSTAHL
STAINLESS

PATENTED

M14

INTEGRIERT
INTEGRATED



TRIMMABLE

EDELSTAHL[®]
**Rost
frei**



Suitable for

ALL METALS · WOOD

CLEAN Disc MCD

for drills and polishers

Cleans and removes pore-deep paint, rust, scale, and dirt on all materials – even wood. Effect is similar to that of sand-blasting: cleans without removing material. Ideal for car bodywork, the automotive industry, shipyards, and renovation work by commercial decorators and builders.

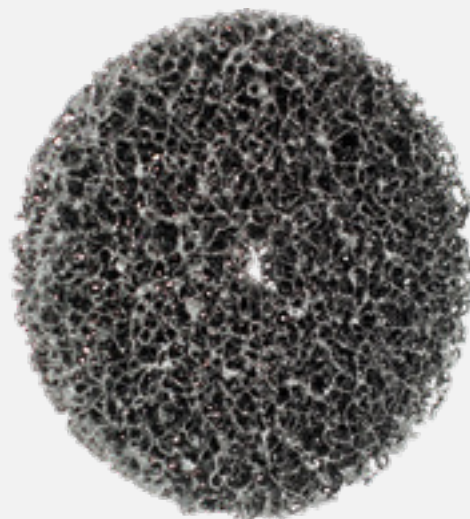

Technical data:

Dimensions (mm)	Mount	Maximum speed (rpm)	Material thickness (mm)	Packaging unit	Article number
Ø 115	for clamping shaft	5,000	13	10	61115
Ø 150	for clamping shaft	4,000	13	10	61150
Clamping shaft	8 mm steel shaft			1	61151



Suitable for

ALL METALS · WOOD · BRICK

Clean Disc

Cleans and removes pore-deep paint, rust, scale, and dirt on all materials. Effect is similar to that of sand-blasting: cleans without removing material. Ideal for car bodywork, the automotive industry, shipyards, and renovation work by commercial decorators and builders. With a hook & loop backing.

Available for these quick-change systems:



FIX HOOK & LOOP
MORE DETAILS ON P. 144



MINI FIX HOOK & LOOP
MORE DETAILS ON P. 124

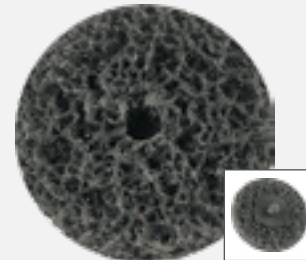

PINLOC
MORE DETAILS ON P. 135

Suitable for

ALL METALS · WOOD · HARD PLASTICS

NEW

MAGNUM® DecoFinish

The open-pore design achieves especially fine, decorative results on all metals, hard plastics, and wood. Fine weld seams, spot welds, and deep scratches can be directly removed at the same time, depending on contact pressure. The especially fine finish allows an immediate perfect mirror finish with polishing discs such as those from the BRIGHTEX® polishing system if needed.

The MAGNUM® DecoFinish is certainly one of the most modern compact fleece designs on the global market.

YOU CAN FIND MORE DETAILS ON PAGE 88.



TIP: Also great for cleaning!
See pages 88.



FIX HOOK & LOOP in 3 seconds!



MULTIFUNCTIONAL GRINDING

SECTION HIGHLIGHTS 110

POWER TOOLS 112

NEW MINI MAX [®] PRO 1000	112
NEW MINI MAX [®] AKKU	114
NEW MINI MAX [®] AKKU accessories	116
NEW MINI MAX [®] accessory set	117

GRINDING AND BLENDING 118

MINI MAX [®] Expansion roller	118
MINI MAX [®] Zirconium sleeve	118
MINI MAX [®] flap wheel	119

FINISHING AND FINE GRINDING 120

MINI MAX [®] mix wheel	120
MINI MAX [®] fleece wheel	120

POLISHING 121

MINI MAX [®] felt polishing tip	121
MINI MAX [®] clamping shaft	121

TECHNICAL BRUSHES 122

MINI MAX [®] stainless steel wire wheel	122
MINI MAX [®] stainless steel wire brush	122

MINI FIX HOOK & LOOP SYSTEM 123

MINI FIX special backing pad	123
MINI FIX Cool Top [®] flap disc	124
MINI FIX Clean disc	124
MINI FIX SC fleece disc	125
MINI FIX Trizact [™] disc	125
MINI FIX BRIGHTEX [®] Berry & Sun discs	126
MINI FIX SuperPolish disc	127
MINI FIX felt disc	127

PINLOC SYSTEM 128

NEW PINLOC starter set	129
NEW PINLOC backing pad	130
NEW PINLOC HellFire [®] disc	130
NEW PINLOC COLDSTEEL [®] disc	131
NEW PINLOC zirconium disc	131
NEW PINLOC Cool Top [®] flap disc	132
NEW PINLOC Trizact [™] disc	132
NEW PINLOC DecoFinish disc	133
NEW PINLOC SC fleece disc	133
NEW PINLOC BRIGHTEX [®] discs	134
NEW PINLOC SuperPolish disc	135
NEW PINLOC CLEAN disc	135

POWER TOOLS 136

NEW VARILEX [®] 1000	136
NEW VARILEX [®] 1000 accessories	138
NEW VARILEX [®] accessory sets	140

FIX HOOK & LOOP COMPLETE SYSTEM 142

FIX special backing pad	142
FIX Cool Top [®]	143
FIX elastic zirconium disc	144
FIX Clean disc	144
FIX AluPolish	145
FIX SC fleece	146
FIX Trizact [™] disc	147
FIX BRIGHTEX [®] Berry & Sun discs	148
FIX SuperPolish disc	149
FIX felt disc	149

STATIONARY MACHINES 150

MULTI MAX [®] machine	150
MULTI MAX [®] professional set	152
MULTI MAX [®] accessories	153

FLEXIBLE SHAFT 117

Flexible shaft 6 mm connection	117
Flexible shaft M14 connection	153

POWER TOOLS



MINI MAX® PRO 1000 p. 112

MINI MAX® AKKU p. 114

112

BATTERY ACCESSORIES



116

FLEXIBLE SHAFT

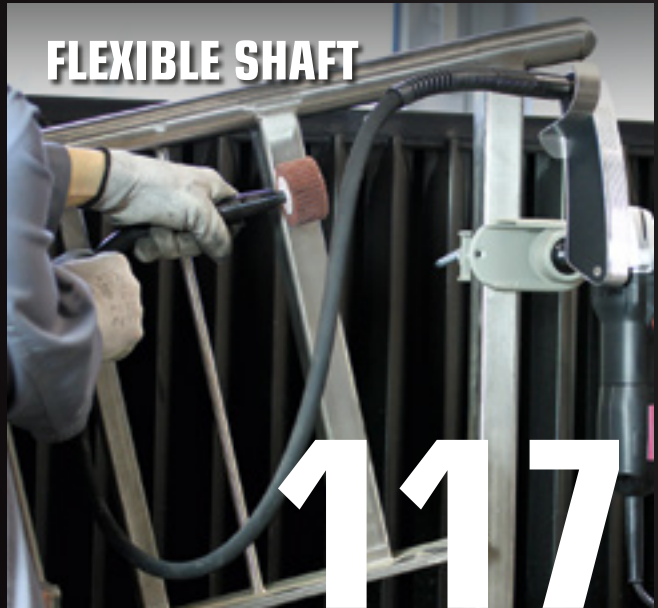

117

SHAFT TOOLS

MINI MAX® flap wheel p. 119

MINI MAX® felt polishing tip p. 121



MINI MAX® zirconium sleeve p. 118



MINI MAX® mix wheel p. 120

118

MINI FIX HOOK & LOOP SYSTEM



123

PINLOC SYSTEM



PINLOC STARTER SET
p. 129

128

VARILEX® 1000

VARILEX® 1000 p. 136

VARILEX® 1000
grinding belt roller p. 138



VARILEX® 1000
expansion roller p. 138



VARILEX® 1000
grinding wheel mount p. 138

136

FIX HOOK & LOOP COMPLETE SYSTEM

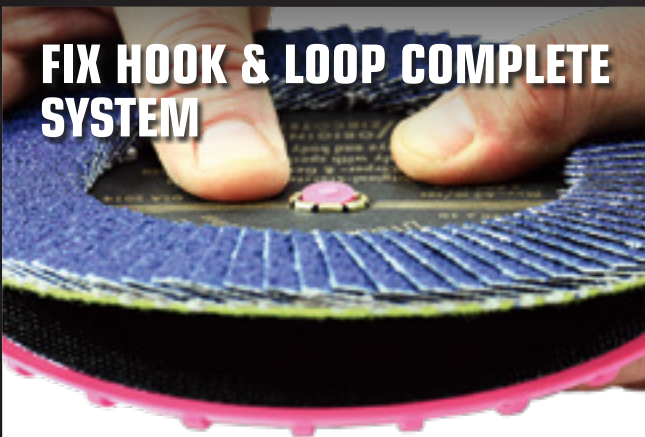

142

STATIONARY MACHINES



MULTI MAX® p. 150

150

MINI MAX[®] PRO 1000 **NEW**

A MINI WORKSHOP FOR ANY TRADE PROFESSIONAL



MINI MAX[®] CAN BE DELIVERED AS A BATTERY-POWERED TOOL!

See pages 114-115

Mini longitudinal and angle grinder and cutter in a single device! Ideal for all 6-mm shaft tools, the MINI-FIX hook and loop system, and the ROLOC[™]/PINLOC systems. Especially sturdy extension arm for versatile work at any point.

OVERVIEW OF PRODUCT ADVANTAGES

- Especially **versatile** and indispensable for **maintenance, repair, fitting work, motor vehicles, paint workshops**, and much more.
- **For grinding jobs in hard-to-reach places** (corners, edges, internal tanks, etc.), coarse grinding, fine grinding, satin finish, matt finish, polishing to a mirror finish, mini-cutting and cut-off grinding.
- **Ideal drive motor for flexible shafts** with a 6 mm shaft (see page 117).
- A new airflow system greatly reduces the operating temperature of the grinding arm and the gear head, making the MINI MAX[®] PRO 1000 eminently suitable for continuous operation.
- **Ideal for Eisenblätter's MINI FIX (p. 123) and PINLOC (p. 128) systems.** Suitable for other systems available on the market, such as ROLOC[™] and FASTLOCK, as well.
- **Extensive range of grinding tools for any grinding task** on stainless steel, steel, non-ferrous metals, aluminium, wood, and plastics.
- Can be used with the **ball joint mount** for secure fixing of the drive motor for work with the **flexible shaft** or as a **stationary grinder** (see page 289).



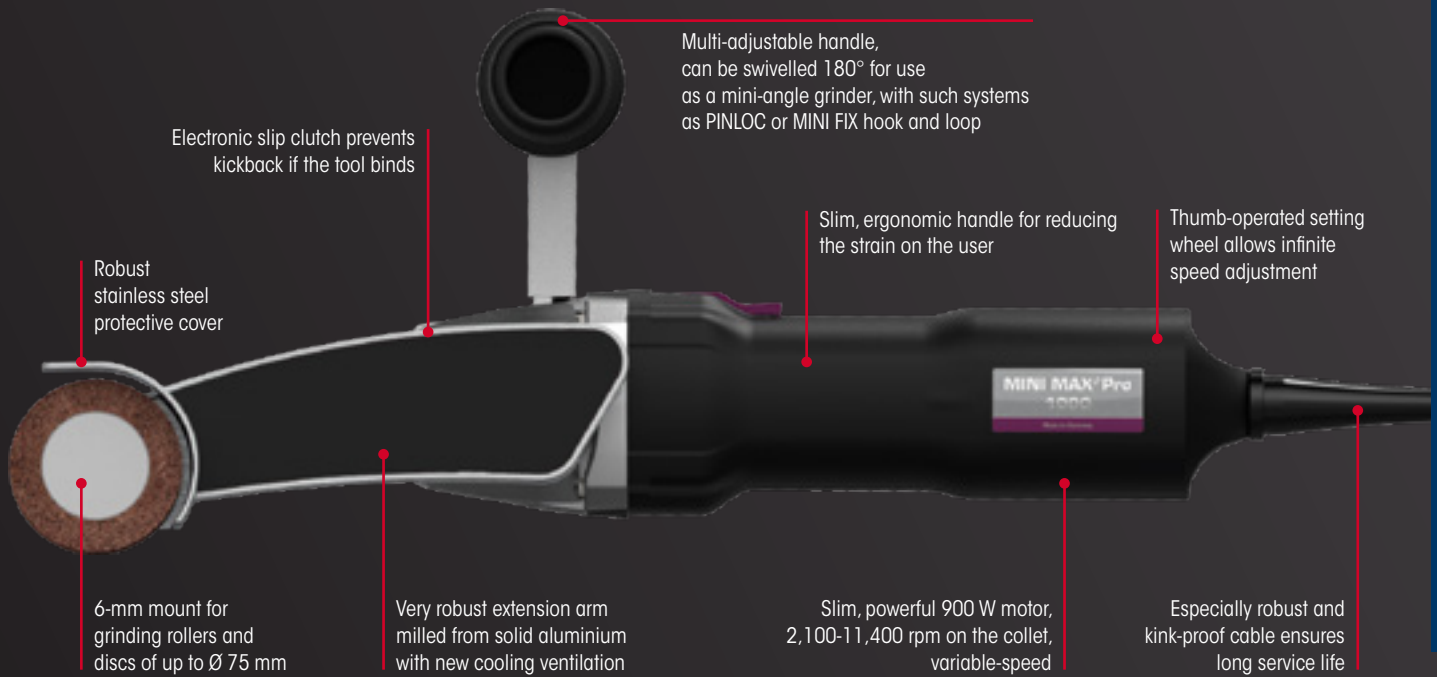

The machine can be rotated 90° to become a mini angle grinder with the MINI FIX, FIX HOOK & LOOP, and PINLOC systems

Optional: Ball joint mount (see page 289) for stationary fixing on workbenches, etc. and flexible shaft (page 117)



Technical data **MINI MAX® PRO 1000 basic set**

Plug type	Cable type	Mains connection (V ~ Hz)	Power (W)	Mount (mm)	Speed (rpm)	Weight (kg)	Pkg. unit	Article number
EU (C+F)	Permanent connection	220-240 ~ 50-60	900	Collet for Ø 6	2,100-11,400	2.72	1	10031



- Set contents:**
- 1 MINI MAX® PRO 1000 machine
 - 1 robust, impact-resistant plastic case for machine and accessories
 - 1 MINI FIX backing pad
 - 1 MINI FIX Cool Top® flap disc
 - 1 fleece wheel, 6 mm shaft

Please Note: For the practical accessory set, see page 117.

MINI MAX[®] AKKU **NEW**

THE MINI WORKSHOP FOR THE ROAD

MULTIFUNCTIONAL GRINDING



Mini longitudinal and angle grinder and cutter in a single device! Ideal for all 6-mm shaft tools, the MINI-FIX hook and loop system, and the ROLOC™/PINLOC systems. Especially sturdy extension arm for versatile work at any point.

OVERVIEW OF PRODUCT ADVANTAGES

- Indispensable for maintenance, repair, fitting work, motor vehicles, paint workshops, and much more.
- **Can also be used as a drive motor for flexible shafts** with a 6 mm shaft.
- **Also ideal for all ROLOC™ and PINLOC systems.**
- **Extensive range of grinding tools for any grinding task** on stainless steel, steel, non-ferrous metals, aluminium, wood, and plastics.
- **For grinding jobs in hard-to-reach places** (corners, edges, internal tanks, etc.), coarse grinding, fine grinding, satin finish, matt finish, polishing to a mirror finish, mini-cutting and cut-off grinding.
- Can be used with the **ball joint mount** for secure fixing of the drive motor, including for work with the **flexible shaft** or as a **stationary grinder**.
- **Powerful 18-volt special motor**, made in Germany.



CAS CORDLESS ALLIANCE SYSTEM

100% COMPATIBLE

melabo ROTHENBERGER mafell
 Collomix EISENBLÄTTER HILTI
 starmix haagga STEINEL

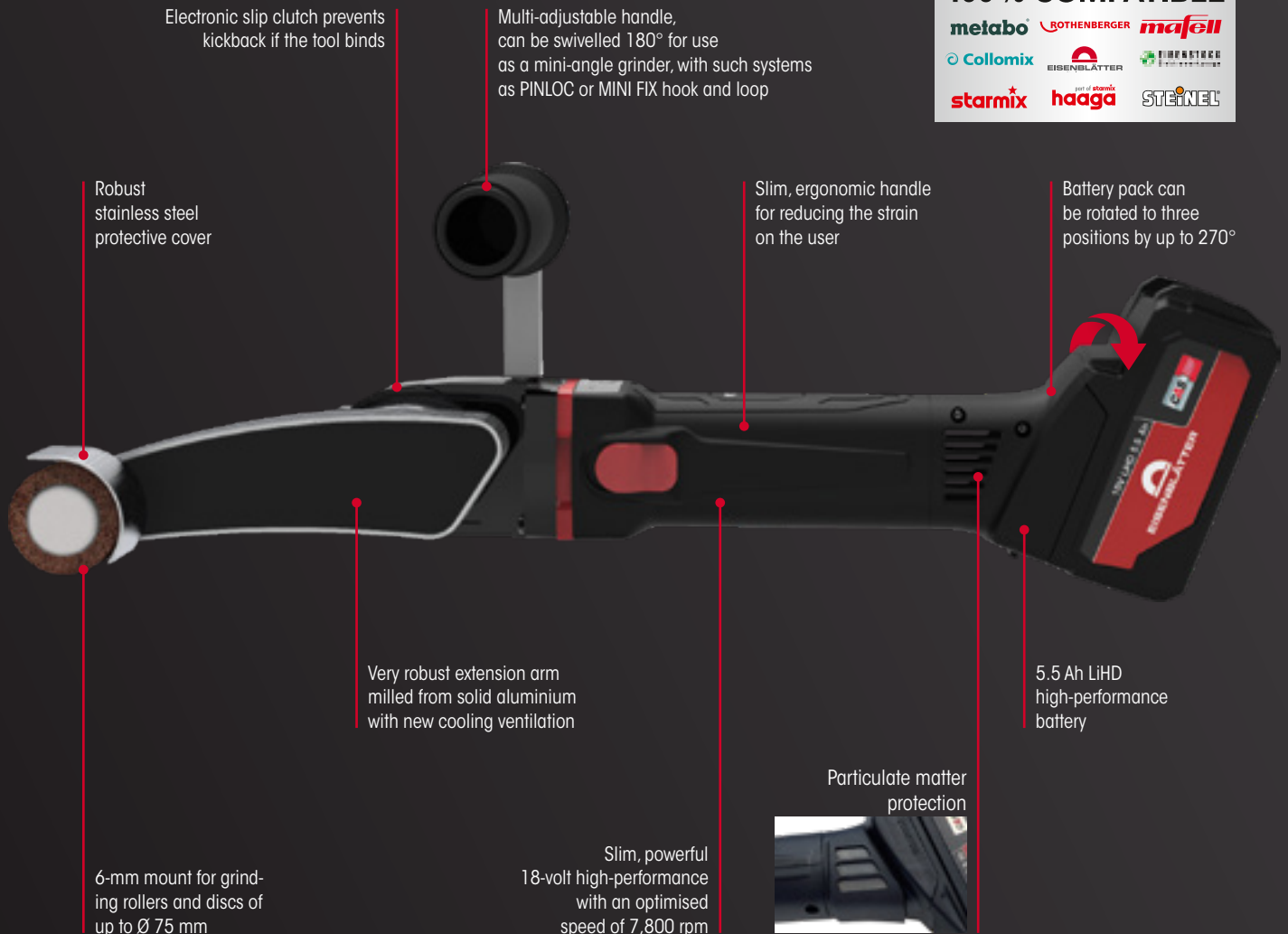

MULTIFUNCTIONAL GRINDING

Technical data MINI MAX® AKKU basic set

Plug type	Cable type	Mains connection (V ~ Hz)	Power (V)	Mount (mm)	Speed (rpm)	Weight (kg)	Pkg. unit	Article number
EU (C+F)	Permanent connection	220-240 ~ 50-60	18	Collet for Ø 6	7,800	2.0	1	10041



- Set contents:**
- 1 MINI MAX® AKKU machine
 - 1 robust, impact-resistant plastic case for machine and accessories
 - 1 particulate matter protection battery
 - 2 LiHD batteries (5.5 Ah)
 - 1 high-speed charging device including cable
 - 1 MINI FIX backing pad
 - 1 MINI FIX Cool Top® flap disc
 - 1 fleece wheel, 6 mm shaft

Please Note: For the practical accessory set, see page 117.

POWER TOOLS

CORDLESS ALLIANCE SYSTEM

Suitable for

ALL CORDLESS ALLIANCE BATTERIES



High-speed Charging Device

NEW



For quick charging of all sliding-fit Li-ion and LiHD battery packs from 14.4 to 36 volts.

FEATURES

- **Patented "AIR COOLED" charging technology:** Batteries are cooled during charging for a much shorter charging time.
- High charging current ensures that the **battery packs are charged quickly.**
- Very **low stand-by power consumption.**
- Maximum charging current: 6.5 A.
- **Process-controlled charge management** for gentle charging and the greatest possible number of charging cycles.
- One charger for charging all battery packs from our CAS partner: www.cordless-alliance-system.de

Technical data:

Plug type	Cable type	Mains connection (V ~ Hz)	Maximum charging current (A)	Pkg. unit	Article number
EU (C+F)	Permanent connection	220-240 ~ 50-60	6.5	1	50474

Suitable for

ALL CORDLESS ALLIANCE SYSTEM DEVICES



5.5/8.0 Ah Battery

NEW



18 volts, LiHD technology

Powerful high-tech 18-volt battery (LiHD) for all battery-powered tools in the CAS group.

Technical data:

Article	Power (V)	Battery capacity (Ah)	Suitable for	Weight (kg)	Pkg. unit	Article number
5.5 Ah CAS battery	18	5.5	CAS devices	0.89	1	50463
8.0 Ah CAS battery	18	8.0	CAS devices	0.98	1	50473

Suitable for

MINI MAX® PRO 1000 · MINI MAX® AKKU

MINI MAX® PRO Accessory Set



The practical accessory set consists of a wide selection of tools for work ranging from coarse grinding to perfect mirror finish. Everything is ready to go in a practical, sturdy carrying case.

Technical data:

Function	Can be used with:	Mount	Pkg. unit	Article number
From coarse grinding to perfect mirror finish	MINI MAX® PRO 1000 · MINI MAX® AKKU	6 mm	1	10032

Contents:

- | | | |
|--------------------------|---------------------------------------|-------------------------------|
| 1 tool case | 3 felt polishing tips | 2 BRIGHTEX® mini pastes |
| 2 flap wheels | 1 MINI FIX backing pad | 1 BRILLIANCE CLEAN 50 ml |
| 2 mix wheels | 1 MINI FIX Clean disc | 1 Power Cleaner 50 ml |
| 2 fleece wheels | 2 MINI FIX SC fleece discs | 1 INOX PROTECT 50 ml |
| 2 mini expansion rollers | 2 MINI FIX flap discs | 2 BRIGHTEX® microfibre cloths |
| 8 zirconium sleeves | 10 MINI FIX BRIGHTEX® polishing discs | 1 BRIGHTEX® Softclean Powder |

Suitable for

MINI MAX®

Flexible Shaft

Flexible shaft with steel core for working in cramped and particularly hard-to-access places. All grinding tools in the MINI MAX® range can also be used with the flexible shaft.



Technical data:

Length (mm)	Collet (mm)	Mount	Maximum speed (rpm)	Can be used with (Ø mm)	Packaging unit	Article number
1,400	Ø 6	6 mm steel shaft	25,000	up to 75	1	10010



Suitable for

MINI MAX® ZIRCONIUM SLEEVE

MINI MAX® Expansion Roller



Expanding rubber roller for safely mounting MINI MAX® zirconium sleeves.

Technical data:

Dimensions (mm)	Mount	Maximum speed (rpm)	Packaging unit	Article number
Ø 30 x 30	6 mm steel shaft	12,000	1	10201
Ø 45 x 30		12,000	1	10202



ACCESSORIES

Suitable for

STEEL · STAINLESS STEEL · NON-FERROUS METALS

MINI MAX® Zirconium Sleeve



Zirconium sleeves are simply attached to the expansion roller.

For general material removal and elimination of weld seams, heavy burring, deep scratches, etc.

Technical data:

Dimensions (mm)	Maximum speed (rpm)	Packaging unit	Grit (K)	Article number
Ø 30 x 30	12,000	50	40	10214
			60	10216
			80	10218
Ø 45 x 30	12,000	50	40	10224
			60	10226
			80	10228



STAHL
STEEL



EDELSTAHL
STAINLESS



BUNTMETALLE
NF METALS

Suitable for

ALL METALS · WOOD · HARD PLASTICS

MINI MAX[®] Flap Wheel



Highly elastic flaps for cleaning, removing rust and scratches, and linear grinding.

Technical data:

Dimensions (mm)	Mount	Speed (rpm)	Material	Packaging unit	Grit (K)	Article number
Ø 40 x 10	6 mm steel shaft	max. 12,000	High-quality corundum	10	40	11040
					60	11060
					80	11080
					100	11100
Ø 60 x 30	6 mm steel shaft	max. 12,000	High-quality corundum	10	40	11041
					60	11061
					80	11081
					100	11101



Suitable for

STEEL · STAINLESS STEEL · NON-FERROUS METALS · WOOD · HARD PLASTIC

MINI MAX[®] Mix Wheel

For removing minor scratches, oxide, and paint.
Applying linear structures.



Technical data:

Dimensions (mm)	Mount	Maximum speed (rpm)	Material	Packaging unit	Grit (K)	Article number
Ø 40 x 20	6 mm steel shaft	17,100	Nylon fleece in combination with abrasive cloth	10	80	14080
					150	14150
					240	14240
Ø 60 x 30	6 mm steel shaft	11,500	Nylon fleece in combination with abrasive cloth	10	80	14081
					150	14151
					240	14241



Suitable for

ALL METALS · WOOD · HARD PLASTIC

MINI MAX[®] Fleece Wheel

For matt finishing, fine grinding, and removing oxide.
For smoothing wood fibre and hard plastic.
Application of fine linear structures (finish).



Technical data:

Dimensions (mm)	Mount	Maximum speed (rpm)	Material	Packaging unit	Grit (fleece)	Grit (fleece)	Grit (approx. K)	Article number
Ø 40 x 20	6 mm steel shaft	17,100	Flexible nylon fleece impregnated with grit	10	coarse	M	80	13001
					medium	F	180	13002
					fine	VF	280	13003
					very fine	UF	400	13004
Ø 60 x 30	6 mm steel shaft	11,500	Flexible nylon fleece impregnated with grit	10	extra-course	C	60	13010
					coarse	M	80	13011
					medium	F	180	13012
					fine	VF	280	13013
					very fine	UF	400	13014



Suitable for

STAINLESS STEEL · NON-FERROUS METALS · HARD PLASTICS

MINI MAX[®] Felt Polishing Tip



First-class Merino felt tips for polishing in corners, cavities, and recesses. For use only in connection with polishing pastes or creams (page 100).

Technical data:

Dimensions (mm)	Mount	Shape	Material	Packaging unit	Article number
Ø 20 x 25	6 mm steel shaft	round	Merino felt	10	10020
Ø 30 x 35	6 mm steel shaft	cylindrical	Merino felt	10	10021
Ø 15 x 30	6 mm steel shaft	conical	Merino felt	10	10022



Suitable for

POLISHING RINGS · WIRE WHEELS

MINI MAX[®] Clamping Shaft

With support discs and locking nut



Clamping shaft for polishing rings and 12-mm-wide wire wheels used with the MINI MAX[®], flexible shaft, drills, or straight grinders.

SUITABLE FOR POLISHING RINGS (STARTING ON PAGE 194) AND WIRE WHEELS (STARTING ON PAGE 202).

Technical data:

Mount (mm)	Material	Maximum speed (rpm)	Packaging unit	Article number
6 mm steel shaft	Steel, blackened	8,000	1	10017

Suitable for

STEEL · STAINLESS STEEL · NON-FERROUS METALS

MINI MAX[®] Stainless Steel Wire Wheel



For deburring and cleaning weld seams, paint, rust, etc.

Technical data:

Dimensions (mm)	Mount (mm)	Wire thickness (mm)	Maximum speed (rpm)	Material	Packaging unit	Article number
Ø 60 x 10	6 mm steel shaft	0.2	15,000	Stainless steel 1.4310	5	10019



Suitable for

STEEL · STAINLESS STEEL · NON-FERROUS METALS

MINI MAX[®] Stainless Steel Wire Brush



For cleaning weld seams, removing scale, paint, and rust in corners, etc.

Technical data:

Dimensions (mm)	Mount (mm)	Maximum speed (rpm)	Material	Packaging unit	Article number
Ø 10 x 100	6 mm steel shaft	15,000	Stainless steel 1.4310	5	10023



Suitable for

MINI FIX TOOLS

MINI FIX Special Backing Pad

Flexible backing pad of wear-resistant polyurethane material with hook & loop fastening and centring pin to ensure that the disc runs perfectly without vibration. The ventilation slots ensure lower temperature during grinding.

Optional: A flexible damping adapter with hook & loop fastening and a special damping layer. The 10-mm centring pin is visible for exact grinding disc centring.



Technical data:

Article	Dimensions (mm)	Mount	Maximum speed (rpm)	Material	Hook & loop	Pkg. unit	Article number
Special backing pad	Ø 60	Ø 6 mm steel shaft	20,000	Polyurethane plastic	Mushroom hook & loop	1	10100
Special backing pad	Ø 60	M14 thread	20,000	Polyurethane plastic	Mushroom hook & loop	1	10100b
Soft damping adapter	Ø 60	Hook & loop	20,000	Foam	Harpoon hook & loop	5	10105

Which backing pad with which tool?

MINI FIX backing pad with mushroom-shaped hook & loop



MINI FIX Soft damping adapter with harpoon hook & loop

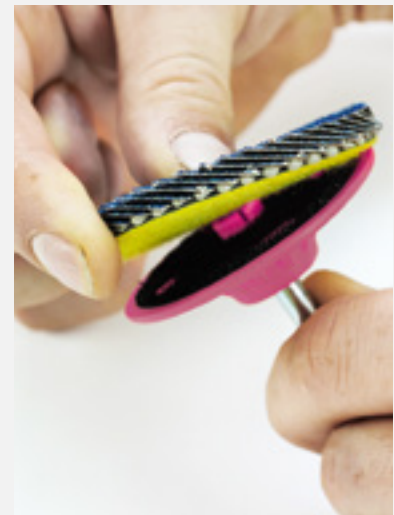

Perfect mirror finish with VARILEX® 1000 and MINI FIX hook and loop system



Use of a MINI FIX Cool Top® flap disc



MINI FIX HOOK & LOOP SYSTEM

Suitable for

STEEL · STAINLESS STEEL

MINI FIX Cool Top® Flap Disc



Quick-change mini zirconium flap disc

Ultra-long service life; high material removal; uniform, clean results without material discolouration; adjusts ideally to the workpiece. On environmentally-friendly fibre backing material. Ideal for tool construction, small workpieces and spot repairs.

Technical data:

Dimensions (mm)	Ideal speed (rpm)	Maximum speed (rpm)	Backing	Packaging unit	Grit (K)	Article number
Ø 63	6,000-10,000	19,000	Hook & loop	20	40	10134
					60	10136
					80	10138
					120	10139



Suitable for

ALL METALS · WOOD · BRICK

MINI FIX Clean Disc



Cleans and removes pore-deep paint, rust, scale, and dirt on all materials. Effect is similar to that of sand-blasting: cleans without removing material. Ideal for car bodywork, the automotive industry, shipyards and renovation work by commercial decorators and builders.

Technical data:

Dimensions (mm)	Ideal speed (rpm)	Maximum speed (rpm)	Material thickness (mm)	Backing	Packaging unit	Article number
Ø 63	6,000-8,000	12,000	13	Hook & loop	20	10101



Suitable for

STEEL · STAINLESS STEEL · NON-FERROUS METALS · WOOD · HARD PLASTICS

MINI FIX SC Fleece Disc

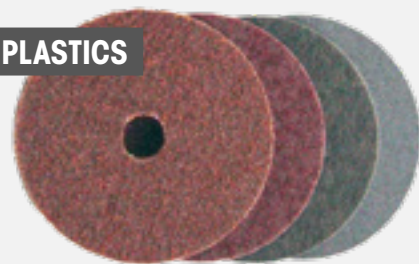

Technical surface conditioning fleece ideally suited for deburring, fine grinding and removing minor scratches and oxide layers on metals and other materials.

Technical data:

Dimensions (mm)	Ideal speed (rpm)	Maximum speed (rpm)	Material	Backing	Pkg. unit	Grit (K)	Colour (fleece)	Grit (fleece)	Article number
Ø 60	6,000-10,000	19,000	SC nylon fleece with reinforcing fabric	Hook & loop	20	80	brown	coarse	10151
						180	red	medium	10152
						280	blue	fine	10153
						400	grey	very fine	10154



Suitable for

STEEL · STAINLESS STEEL

MINI FIX Trizact™ Disc

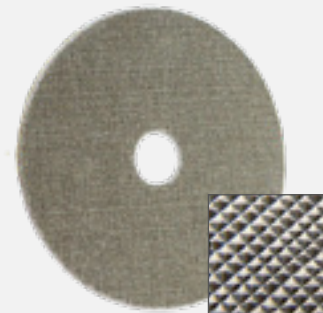

New type of **abrasive cloth** with **pyramid-shaped grit structure** and additional **heat-insulating layer**. **Saves** on several **operating steps** and has high material removal with very **fine results while removing scratches and spot welds**. Ideal pre-polishing for subsequent mirror-finish polishing. Leaves **very minor surface roughness**.

Technical data:

Dimensions (mm)	Ideal speed (rpm)	Maximum speed (rpm)	Backing	Pkg. unit	Grit (Trizact™)	Grit (K)	Removes material like (like approx. K)	Article number
Ø 60	6,000-10,000	19,000	Hook & loop	20	A100	220	36	10141
					A65	280	40	10142
					A45	400	50	10143
					A30	600	60	10144
					A16	1200	80	10145
					A06	2000	120	10146



MINI FIX HOOK & LOOP SYSTEM

Suitable for

ALL METALS

MINI FIX BRIGHTEX® Disc Berry & Sun

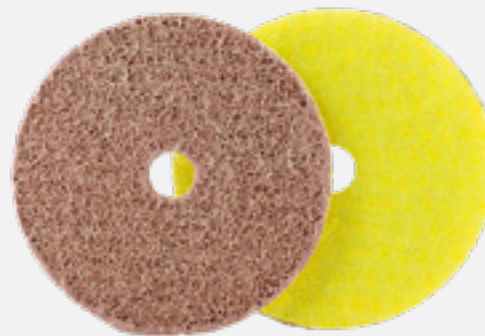

Polishing material that is already impregnated with **BRIGHTEX® polishing paste** removes the time-consuming hassle of applying pastes and creams to give untreated metal a **shadow-free mirror finish**.

FEATURES

Step 1: BRIGHTEX® Berry (pre-polishing):

- For applying a rapid high-gloss polish to all metals.
- Pre-polish and main polish in one – save on additional operations.

Step 2: BRIGHTEX® Sun (main polish):

- A mirror finish that's almost like chrome plating – perfect finish.
- For a final high-gloss shine on polished metals.
- For removing any residual clouding and smears from all metals.

• Please Note:

After changing pastes, always remove the polish residue from the workpiece! As necessary, the backing can be rewetted with BRIGHTEX® pastes.

- For mechanical main polish and reconditioning of surfaces which are high-gloss polished.
- Ideal for use with polishing machines and hand-held polishing tools.
- For the best results, use **Eisenblätter care and cleaning products** for removing polish residues (BRIGHTEX® Softclean Powder, Power Cleaner).
- With centring hole for backing pads with centring pins.
- Completely new **high-tech paste formulation** for metals.
- For immediate use without additional pastes and creams!

Technical data:

Dimensions (mm)	Version	Application	Ideal speed (rpm)	Maximum speed (rpm)	Material thickness (mm)	Backing	Pkg. unit	Article number
Ø 60	Berry (pink)	High-gloss polishing	6,000-8,000	19,000	5	Hook & loop	20	10118
Ø 60	Sun (yellow)	Mirror-finish polishing	6,000-8,000	19,000	5	Hook & loop	20	10119



Suitable for

ALL METALS

MINI FIX SuperPolish Disc

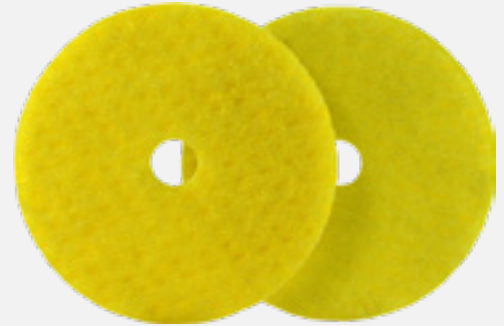

Revolutionary special fleece. Used with polishing pastes and creams for a shiny mirror finish on stainless steel and non-ferrous metals which leaves no smears or shadows.

Please Note: Always use a separate SuperPolish disc for each paste and cream – it is important not to mix different grit sizes.

Technical data:

Dimensions (mm)	Ideal speed (rpm)	Maximum speed (rpm)	Material thickness (mm)	Backing	Pkg. unit	Article number
Ø 60	6,000-8,000	19,000	5	Hook & loop	20	10117n



Suitable for

ALUMINIUM · NON-FERROUS METALS · HARD PLASTICS

MINI FIX Felt Disc



First-class Merino felt for rapid mirror finish using polishing pastes and creams that leave no scratches or smears.

Please Note: Always use a separate felt disc for each paste and cream – it is important not to mix different grit sizes.

Technical data:

Dimensions (mm)	Ideal speed (rpm)	Maximum speed (rpm)	Material thickness (mm)	Material	Backing	Pkg. unit	Article number
Ø 60	6,000-8,000	19,000	5	Merino felt	Hook & loop	20	10117





EISENBLÄTTER PINLOC

offers many discs for a wide variety of possible uses – from coarse grinding to mirror-finish polishing on all metals!



NEW

Suitable for

COARSE GRINDING TO A MIRROR FINISH

PINLOC Starter Set



Disc change is easy, quick, and safe – from extra-coarse to a perfect mirror finish

In prototype construction, individual steel construction, and assembly operations, it is especially common for a wide variety of discs to be used until the desired result is achieved. The PINLOC quick-change system makes it much easier for you to change your tools, since discs are attached by simply screwing them onto the PINLOC backing pad – without any other tools, such as a chuck key, whatsoever. Contains tools with three different diameters (50/60/75 mm) for work from coarse grinding (such as removing weld seams) to perfect mirror finishing on all metals.

Technical data:

Function	Can be used with:	Pkg. unit	Article number
Coarse grinding to a mirror finish	MINI MAX®, MINI MAX® PRO, MINI MAX® AKKU, straight grinders, with optional backing pad with M14 threads, and angle grinders	1	15001

Set contents:

- 1 PINLOC backing pad, 50 mm with 6 mm shaft
- 1 PINLOC HellFire® disc, 50 mm
- 4 PINLOC zirconium discs, 50 mm
- 2 PINLOC Coldsteel discs, 50 mm
- 3 PINLOC SC fleece discs, 50 mm
- 3 PINLOC Trizact™ discs, 50 mm
- 4 PINLOC Cool Top® flap discs, 63 mm
- 1 PINLOC Clean disc, 63 mm
- 1 PINLOC DecoFinish disc, 60 mm

- 1 PINLOC SuperPolish disc, 60 mm
- 2 PINLOC BRIGHTEX® polishing discs, 60 mm, Berry & Sun
- 1 PINLOC backing pad, 75 mm with 6 mm shaft
- 1 PINLOC HellFire® disc, 75 mm
- 4 PINLOC zirconium discs, 75 mm
- 2 PINLOC Coldsteel discs, 75 mm
- 3 PINLOC SC fleece discs, 75 mm
- 3 PINLOC Trizact™ discs, 75 mm



MULTIFUNCTIONAL GRINDING

Suitable for

PINLOC TOOLS

PINLOC Backing Pad



Flexible backing pad with 1/4" thread mount for safely mounting all PINLOC products.

Technical data:

Dimensions (mm)	Mount	Maximum speed (rpm)	Hardness	Disc thread	Pkg. unit	Article number
Ø 50	Ø 6 mm steel shaft	30,000	medium	1/4"	1	15110
Ø 50	M14 thread	30,000	medium	1/4"	1	15150
Ø 75	Ø 6 mm steel shaft	20,000	medium	1/4"	1	15140
Ø 75	M14 thread	20,000	medium	1/4"	1	15160

Suitable for

ALL METALS

PINLOC HellFire[®] Disc

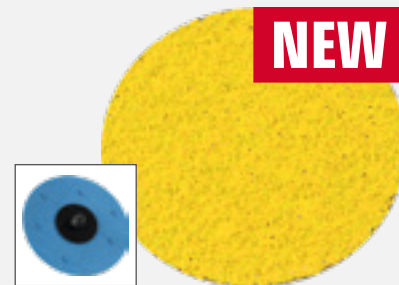

Its unparalleled, innovative ceramic hybrid technology (one disc and grit for all metals) enables it to machine any metal in record time. Material removal like 40 grit with 60 grit grinding results.

Technical data:

Dimensions (mm)	Disc thread	Ideal speed (rpm)	Maximum speed (rpm)	Pkg. unit	Grit (K)	Article number
Ø 50	1/4"	10,000-15,000	30,000	50	Multigrain 40/60	15215
Ø 75	1/4"	10,000-15,000	20,000	50	Multigrain 40/60	15245



Suitable for

STEEL · STAINLESS STEEL

PINLOC COLDSTEEL® Disc

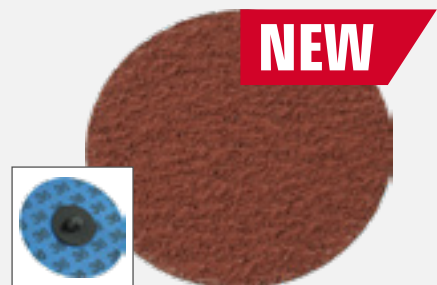

High-tech ceramic fibre disc with significantly more self-sharpening edges due its ultra-fine grit and crystal structure and a corresponding material removal rate that greatly exceeds that of conventional fibre discs.

Technical data:

Dimensions (mm)	Disc thread	Ideal speed (rpm)	Maximum speed (rpm)	Pkg. unit	Grit (K)	Article number
Ø 50	1/4"	10,000-15,000	30,000	50	36	15412
					60	15416
Ø 75	1/4"	10,000-15,000	20,000	50	36	15442
					60	15446



Suitable for

STEEL · STAINLESS STEEL

PINLOC Zirconium Disc



Zirconium fibre disc with outstanding results for coarse grinding and pre-polishing. Levels weld seams and removes scratches. Ideal for work on car bodies and in motor vehicle workshops.

Technical data:

Dimensions (mm)	Disc thread	Ideal speed (rpm)	Maximum speed (rpm)	Pkg. unit	Grit (K)	Article number
Ø 50	1/4"	10,000-15,000	30,000	50	36	15312
					60	15316
					80	15318
Ø 75	1/4"	8,000-12,000	20,000	50	36	15342
					60	15346
					80	15348



Suitable for

STEEL · STAINLESS STEEL

PINLOC Cool Top® Flap Disc



Ultra-long service life; high material removal; uniform, clean results without material discolouration; adjusts ideally to the workpiece. On environmentally-friendly fibre backing material. Ideal for tool construction, small workpieces, and spot repairs.

Technical data:

Dimensions (mm)	Disc thread	Ideal speed (rpm)	Maximum speed (rpm)	Pkg. unit	Grit (K)	Article number
Ø 63	1/4"	10,000-15,000	19,000	20	40	15734
					60	15736
					80	15738
					120	15739



Suitable for

STEEL · STAINLESS STEEL

PINLOC Trizact™ Disc



New type of **abrasive cloth** with **pyramid-shaped grit structure** and additional **heat-insulating layer**. **Saves** on several **operating steps** and has high material removal with very **fine results while removing scratches and spot welds**. Ideal pre-polishing for subsequent mirror-finish polishing. Leaves **very minor surface roughness**.

Technical data:

Dimensions (mm)	Disc thread	Ideal speed (rpm)	Maximum speed (rpm)	Pkg. unit	Grit (K)	Article number
Ø 50	1/4"	10,000-15,000	30,000	50	A45	15614
					A30	15615
					A16	15616
Ø 75	1/4"	6,000-10,000	20,000	50	A45	15644
					A30	15645
					A16	15646



Suitable for

ALL METALS · WOOD · HARD PLASTICS

PINLOC DecoFinish Disc



The open-pore design achieves especially fine, decorative results on all metals, hard plastics, and wood. Fine weld seams, spot welds, and deep scratches can be directly removed at the same time, depending on contact pressure. The MAGNUM® DecoFinish also means that rust and oxide layer are no obstacle to a perfect final finish. This new compact fleece can be used for a variety of applications. It is extremely tough and durable, does not clog pores, and has damping, cooling properties that allow perfect workpiece adaptation and soft grinding transitions.

Technical data:

Dimensions (mm)	Disc thread	Ideal speed (rpm)	Maximum speed (rpm)	Material thickness (mm)	Pkg. unit	Article number
Ø 60	1/4"	6,000-8,000	19,000	13	20	15820



Suitable for

STEEL · STAINLESS STEEL · NON-FERROUS METALS · WOOD · HARD PLASTICS

PINLOC SC Fleece Discs



Technical surface conditioning fleece ideally suited to deburring, fine grinding, and **removing oxide layers** on metals and other materials.

Technical data:

Dimensions (mm)	Disc thread	Ideal speed (rpm)	Maximum speed (rpm)	Pkg. unit	Grit (K)	Colour (fleece)	Grit (fleece)	Article number
Ø 50	1/4"	8,000-12,000	30,000	25	80	brown	coarse	15513
					180	red	medium	15514
					280	blue	fine	15515
Ø 75	1/4"	6,000-15,000	10,000	25	80	brown	coarse	15543
					180	red	medium	15544
					280	blue	fine	15545

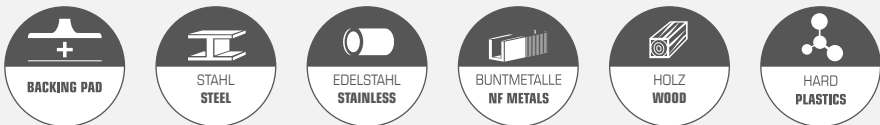

Suitable for

ALL METALS

PINLOC BRIGHTEX® Discs Berry & Sun



Polishing material that is **already impregnated with BRIGHTEX® polishing paste** removes the time-consuming hassle of applying pastes and creams to give untreated metal a **shadow-free mirror finish**.

FEATURES

Step 1: BRIGHTEX® Berry (pre-polishing):

- For applying a rapid high-gloss polish to all metals.
- Pre-polish and main polish in one – save on additional operations.

Step 2: BRIGHTEX® Sun (main polish):

- A mirror finish that's almost like chrome plating – perfect finish.
- For a final high-gloss shine on polished metals.
- For removing any residual clouding and smears from all metals.

• Please Note:

After changing pastes, always remove the polish residue from the workpiece! As necessary, the backing can be rewetted with BRIGHTEX® pastes.

- For mechanical main polish and reconditioning of surfaces which are high-gloss polished.
- Ideal for use with polishing machines and hand-held polishing tools.
- For the best results, use **Eisenblätter care and cleaning products** for removing polish residues (BRIGHTEX® Softclean Powder, Power Cleaner).
- With centring hole for backing pads with centring pins.
- Completely new **high-tech paste formulation** for metals.
- For immediate use without additional pastes and creams!

Technical data:

Dimensions (mm)	Version	Application	Disc thread	Ideal speed (rpm)	Maximum speed (rpm)	Material thickness (mm)	Pkg. unit	Article number
Ø 60	Berry (pink)	High-gloss polishing	1/4"	6,000-8,000	19,000	5	25	15921
Ø 60	Sun (yellow)	Mirror-finish polishing	1/4"	6,000-8,000	19,000	5	25	15922



Suitable for

ALL METALS

PINLOC SuperPolish Disc

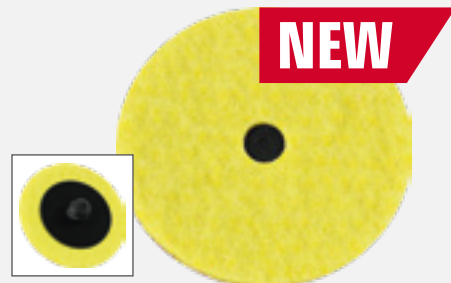

Revolutionary special fleece. Used with polishing pastes and creams for a shiny mirror finish on stainless steel and non-ferrous metals which leaves no smears or shadows.

Please Note: Always use a separate SuperPolish disc for each paste and cream – it is important not to mix different grit sizes.

Technical data:

Dimensions (mm)	Disc thread	Ideal speed (rpm)	Maximum speed (rpm)	Material thickness (mm)	Pkg. unit	Article number
Ø 60	1/4"	6,000-8,000	19,000	5	25	15830



Suitable for

ALL METALS

PINLOC CLEAN Disc



Cleans and removes pore-deep paint, rust, scale, and dirt on all materials. Effect is similar to that of sand-blasting: cleans without removing material. Ideal for car bodywork, the automotive industry, shipyards, and renovation work by commercial decorators and builders.

Technical data:

Dimensions (mm)	Disc thread	Ideal speed (rpm)	Maximum speed (rpm)	Material thickness (mm)	Pkg. unit	Article number
Ø 63	1/4"	6,000-8,000	19,000	13	20	15810



VARILEX® 1000 **NEW**

THE MULTIFUNCTIONAL, COMPACT POWERHOUSE

MULTIFUNCTIONAL GRINDING



Professional, compact, variable-speed, one-handed angle grinder for universal application – lightweight and powerful. The **Swiss Army Knife** of angle grinders for a wide variety of application areas:

Linear grinding with rollers



Linear grinding with sleeves



Pipe belt grinding



OVERVIEW OF PRODUCT ADVANTAGES

- **Easy-to-use one-handed angle grinder with effective capacity** for flap discs of up to Ø 125 mm. Guaranteed to reduce strain on the user.
- **Compact all-rounder you can keep with you:** Ideal for use for fitting or on construction sites.
- Ideal speed range for a wide variety of tools.
- **High-quality tool in a compact design with low noise emission.**
- **Infinite speed control** from 1,900 rpm to 7,900 rpm.
- Versatile use as an angle grinder, linear grinder, pipe grinder, etc.

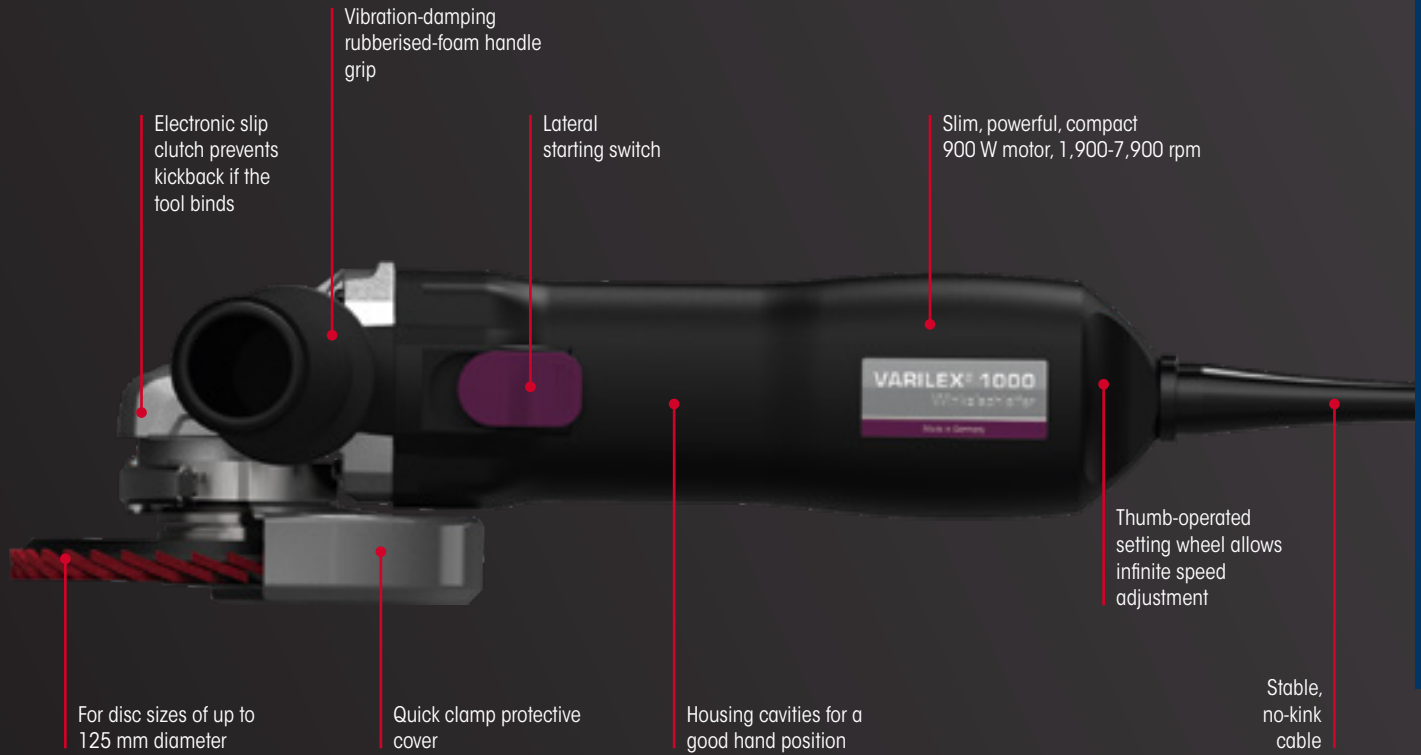

Optional: Ball joint mount (see page 289) for stationary fixing on workbenches, etc.



Perfect mirror finish with VARILEX® 1000 and MINI FIX hook and loop system



Technical data VARILEX® 1000 basic set

Plug type	Cable type	Mains connection (V ~ Hz)	Power (W)	Mount	Speed (rpm)	Weight (kg)	Discs up to (Ø mm)	Pkg. unit	Article number
EU (C+F)	Permanent connection	220-240 ~ 50-60	900	M14 thread	1,900-7,900	2.2	125	1	65301



- Set contents:**
- 1 VARILEX® 1000 machine
 - 1 robust, impact-resistant plastic case for machine and accessories
 - 1 protective cover up to Ø 125 mm
 - 1 clip cut-off wheel cover up to Ø 125 mm
 - 1 locking nut
 - 1 chuck key
 - 10 high-performance flap discs Ø 125 mm
 - 10 premium cutting discs Ø 125 x 1.0 mm

Please Note: For the practical accessory set, see page 140.

Suitable for

SLEEVES of Ø 90 x 50 mm

VARILEX® Expansion Roller

Highly elastic

For using grinding sleeves (Ø 90 x 50 mm) on variable-speed power tools with M14 spindles.

SUITABLE 50-MM-WIDE SLEEVES CAN BE FOUND IN THE LINEAR GRINDING – SATIN GRINDING SECTION STARTING ON PAGE 177.

Technical data:

Dimensions (mm)	Mount	Maximum speed (rpm)	Packaging unit	Article number
Ø 90 x 50	M14 thread	6,000	1	65210



Suitable for

FOR BELTS OF UP TO 30 mm WIDTH

VARILEX® Grinding Belt Roller

Contact wheel with stainless steel flanges

For the use of grinding belts up to 30 mm wide on variable-speed power tools with M14 spindles. For machining open and closed pipe constructions. Wear-resistant vulcan with stainless steel flanges and optimised Shore hardness.

SUITABLE 30-MM-WIDE BELTS CAN BE FOUND IN THE LINEAR GRINDING – SATIN GRINDING SECTION STARTING ON PAGE 205.

Technical data:

Dimensions (mm)	Mount	Maximum speed (rpm)	Packaging unit	Article number
Ø 85 x 70	M14 thread	6,500	1	65215

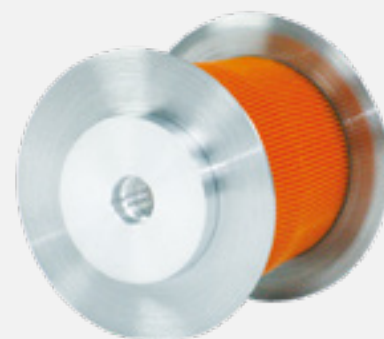

Suitable for

WHEELS, 50 mm WIDTH

VARILEX® Grinding Wheel Mount

For the use of 50-mm-wide grinding wheels on variable-speed power tools with M14 spindles. Suitable grinding rollers and wheels can be found in the POLY-PTX® system. Tightening screw included in delivery.

SUITABLE 50-MM-WIDE BELTS CAN BE FOUND IN THE LINEAR GRINDING – SATIN GRINDING SECTION STARTING ON PAGE 180.

Technical data:

Dimensions (mm)	Mount	Maximum speed (rpm)	Packaging unit	Article number
Ø 19 x 50	M14 thread	6,500	1	65220



Suitable for

VARILEX® 1000 - VARILEX® 1802 HT - VARILEX® AKKU PRO HT

Cut-off Wheel Cover Clip of up to 125 mm

For using cutting discs with VARILEX® 1000 and VARILEX® 1802 HT. Attached to an existing cover with a click.

NEW



Technical data:

Suitable for	Pkg. unit	Article number
VARILEX® 1000, VARILEX® 1802 HT, VARILEX® AKKU PRO HT	1	65045

Suitable for

VARILEX® 1000

FIX Protective Cover

For safe use of the FIX HOOK & LOOP system on the VARILEX® 1000 angle grinder.

NEW



Technical data:

Dimensions (mm)	Packaging unit	Article number
Ø 115	1	65306

Suitable for

VARILEX® 1000 - VARILEX® AKKU PRO HT

Satin Finishing Cover

Protective cover for the safe use of grinding and polishing wheels (Ø 105 x 50 mm) and the grinding belt roller.

NEW

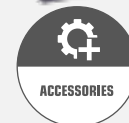

Technical data:

For dimensions up to (mm)	Packaging unit	Article number
Ø 105 x 50	1	50449

POWER TOOLS

PRACTICAL ACCESSORY SETS FOR ANGLE GRINDERS

Suitable for

VARILEX® 1802 HT · AKKU PRO HT · VARILEX® 1000 · VARILEX® WSF 1800

NEW

VARILEX® Coarse and Fine Grinding Accessory Set



This set allows performance of all work, from weld seam removal to surface cleaning to fine grinding, including cleaner and surface sealant. The ideal addition to any VARILEX® angle grinder.

Technical data:

Function	Can be used with:	Pkg. unit	Article number
Coarse and fine grinding	VARILEX® 1802 HT · AKKU PRO HT · VARILEX® 1000 · VARILEX® WSF 1800	1	65032

Contents:

1 mobile tool case	1 MAGNUM® CLEAN-PLUS Ø 125 mm	1 BRIGHTEX® microfibre cloth
1 3D ball handle	1 MAGNUM® CLEAN-STRONG Ø 125 mm	1 INOX PROTECT 50 ml
5 MAGNUM® TWINFLEX® Ø 125 mm	2 MAGNUM® Fleece Top Ø 125 mm	1 BRILLIANCE CLEAN 50 ml
1 TRIMFIX® Fleece Flap 1FOR2 Ø 125 mm	1 COLDSTEEL® backing pad Ø 125 mm	1 Power Cleaner 50 ml
3 TRIMFIX® Fleece Flap Ø 125 mm	8 COLDSTEEL® fibre discs Ø 125 mm	

Suitable for

VARILEX® AKKU PRO HT · VARILEX® 1000

NEW

VARILEX® FIX HOOK & LOOP Accessory Set



The ideal FIX HOOK & LOOP accessory package for diameters **60 and 115 mm**. From coarse and fine grinding to a perfect mirror finish, including cleaner and surface sealing. The ideal addition to any VARILEX® 1000 or VARILEX® AKKU PRO HT angle grinder.

Technical data:

Function	Can be used with:	Pkg. unit	Article number
Coarse grinding to a mirror finish	VARILEX® 1000, VARILEX® AKKU PRO HT	1	65033

Contents:

1 mobile tool case	4 FIX HOOK & LOOP BRIGHTEX® polishing discs, Ø 115 mm	4 MINI FIX BRIGHTEX® polishing discs, Ø 60 mm
1 FIX HOOK & LOOP special backing pad, Ø 115 mm	1 MINI FIX special backing pad, Ø 60 mm	1 BRIGHTEX® Softclean Powder
1 FIX HOOK & LOOP soft damping adapter, Ø 115 mm	1 MINI FIX soft damping adapter, Ø 60 mm	1 BRIGHTEX® microfibre cloth
3 FIX HOOK & LOOP Cool Top®, Ø 115 mm	3 MINI FIX Cool Top®, Ø 60 mm	1 BRILLIANCE CLEAN 50 ml
8 FIX HOOK & LOOP zirconium discs, Ø 115 mm	3 MINI FIX Clean discs, Ø 60 mm	1 INOX PROTECT 50 ml
5 FIX HOOK & LOOP SC fleece discs, Ø 115 mm	5 MINI FIX SC fleece discs, Ø 60 mm	1 Power Cleaner 50 ml
3 FIX HOOK & LOOP Trizact™ discs, Ø 115 mm	3 MINI FIX Trizact™ discs, Ø 60 mm	

NEW

Suitable for

VARILEX® AKKU PRO HT - VARILEX® 1000

VARILEX® Linear Grinding and Pipe Machining Accessory Set



This accessory set turns the VARILEX® 1000 into a miniature workshop. Linear grinding, pipe machining, angular grinding – all with a single machine. The ideal addition to the VARILEX® 1000 or VARILEX® AKKU PRO HT angle grinder.

Technical data:

Function	Can be used with:	Pkg. unit	Article number
Linear and pipe grinding	VARILEX® 1000, VARILEX® AKKU PRO HT	1	65034

Contents:

- 1 mobile tool case
- 1 VARILEX® satin finishing cover
- 1 VARILEX® expansion roller, 90 x 50 mm
- 2 zirconium sleeves, 90 x 50 mm
- 3 SC fleece sleeves, 90 x 50 mm
- 4 Trizact™ sleeves, 90 x 50 mm
- 4 BRIGHTEX® polishing sleeves, 90 x 50 mm
- 1 VARILEX® grinding belt roller
- 1 high-quality corundum grinding belt, 30 x 600 mm
- 1 SC fleece belt, 30 x 650 mm
- 1 BRIGHTEX® microfibre cloth
- 1 BRILLIANCE CLEAN 50 ml
- 1 INOX PROTECT 50 ml
- 1 Power Cleaner 50 ml

VARILEX® 1000 – the Swiss Army Knife of angle grinders. See pages 136.



MULTIFUNCTIONAL GRINDING

FIX HOOK & LOOP COMPLETE SYSTEM

Suitable for

FIX HOOK & LOOP TOOLS

FIX Special Backing Pad

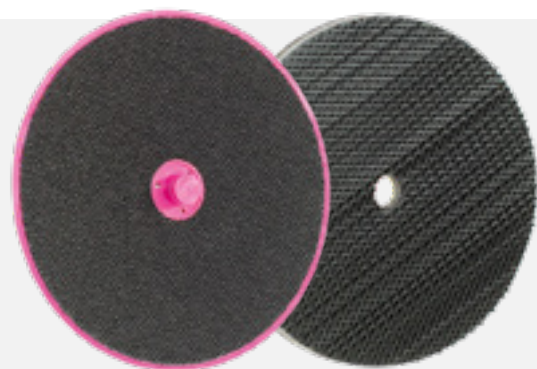

Specially designed pad of flexible polyurethane with a click system, stabilising fins, and 10-mm centring pin to ensure that the disc runs perfectly. Other thread mounts (M10, 5/8") are available upon request.

Optional: A flexible, 6-mm-thick damping adapter with harpoon hook & loop and a special damping layer. The centring pin is visible for exact grinding disc centring.

Technical data:

Article	Dimensions (mm)	Maximum speed (rpm)	Mount	Material	Hook & loop	Pkg. unit	Article number
Special backing pad	Ø 96	11,000	M14 thread	Polyurethane plastic	Mushroom hook & loop	1	80100p
	Ø 110	10,500	M14 thread	Polyurethane plastic	Mushroom hook & loop	1	80115p
	Ø 119	10,100	M14 thread	Polyurethane plastic	Mushroom hook & loop	1	80123p
	Ø 143	8,500	M14 thread	Polyurethane plastic	Mushroom hook & loop	1	80150p
	Ø 168	7,200	M14 thread	Polyurethane plastic	Mushroom hook & loop	1	80160p
Soft damping adapter	Ø 110	10,500	Hook & loop	Foam	Harpoon hook & loop	5	80120
	Ø 143	8,500	Hook & loop	Foam	Harpoon hook & loop	5	80155

Which backing pad with which tool?

FIX HOOK & LOOP backing pad with mushroom-shaped head



Cool Top®	Zirconium disc	Clean	Fleece Top	Felt disc	SuperPolish	BRIGHTEX®

FIX HOOK & LOOP Soft damping adapter with harpoon hook & loop



SC fleece	AluPolish	Zirconium disc	Trizact™	Felt disc	SuperPolish	BRIGHTEX®

FIX HOOK & LOOP COMPLETE SYSTEM

Suitable for

STEEL · STAINLESS STEEL · NON-FERROUS METALS

FIX Cool Top®

With Cool Top® pure zirconium abrasive. **Superb material removal**, extremely long service life, uniformly clean results and **no material discolouration** or smearing. Highly flexible flap disc – adjusts to workpieces of any shape to produce an **unbeatable finish**.



Technical data:

Dimensions (mm)	Ideal speed (rpm)	Maximum speed (rpm)	Approved for (DIN EN 13743)	Backing	Packaging unit	Grit (K)	Article number
Ø 115	7,000-9,000	10,500	63 m/sec	Hook & loop	25	40	80340
						60	80360
						80	80380
						120	80390
Ø 125	6,000-8,000	9,600	63 m/sec	Hook & loop	25	40	80440
						60	80460
						80	80480
						120	80490
Ø 150	6,000-7,000	8,000	63 m/sec	Hook & loop	25	40	80540
						60	80560
						80	80580
						120	80590

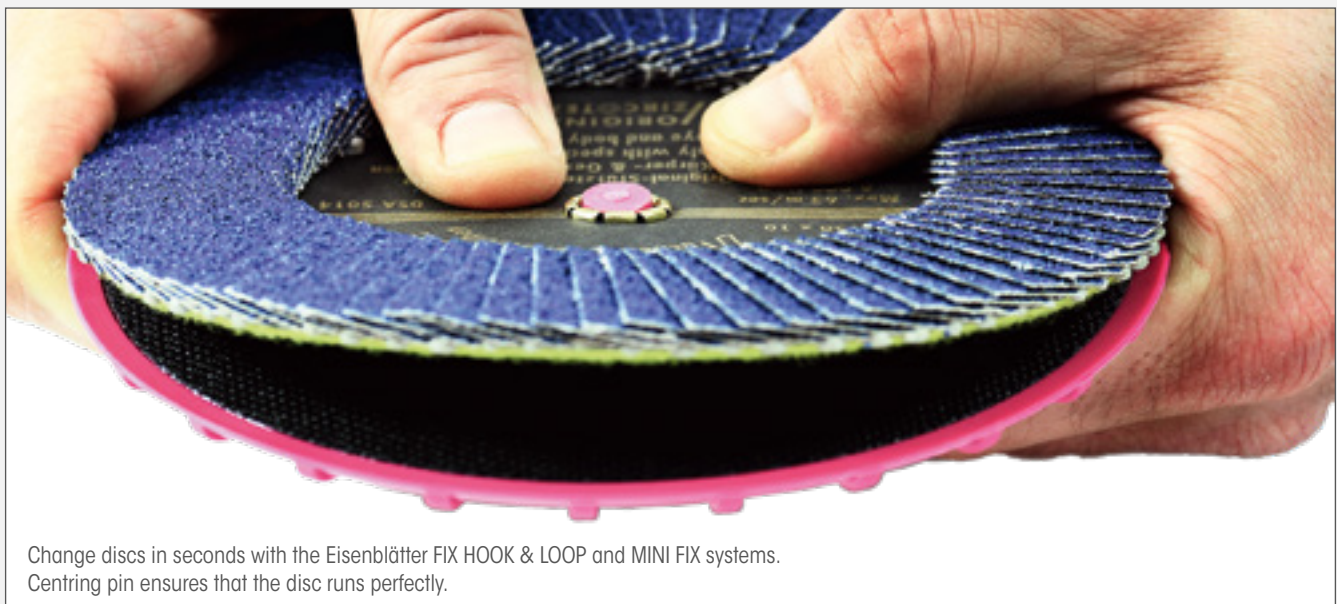
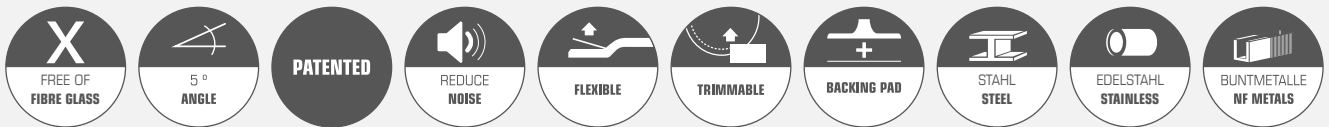

Change discs in seconds with the Eisenblätter FIX HOOK & LOOP and MINI FIX systems. Centring pin ensures that the disc runs perfectly.

FIX HOOK & LOOP COMPLETE SYSTEM

Suitable for

STEEL · STAINLESS STEEL

FIX Elastic Zirconium Disc



Zirconium fibre disc with outstanding results for coarse grinding and pre-polishing. Levels weld seams and removes scratches. Ideal for work on car bodies and in motor vehicle workshops.

Technical data:

Dimensions (mm)	Ideal speed (rpm)	Maximum speed (rpm)	Approved for (DIN EN 13743)	Backing	Packaging unit	Grit (K)	Article number
Ø 115	5,000-10,000	10,500	63 m/sec	Hook & loop	50	40	80904
						60	80906
						80	80908
						120	80909
Ø 150	4,000-8,000	8,000	63 m/sec	Hook & loop	50	40	80914
						60	80916
						80	80918
						120	80919



Suitable for

ALL METALS · WOOD · BRICK

FIX Clean disc

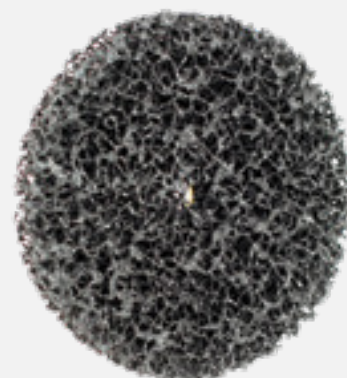

Cleans and removes pore-deep paint, rust, scale, and dirt on all materials. Effect is similar to that of sand-blasting: cleans without removing material.

Ideal for car bodywork, the automotive industry, shipyards, and renovation work by commercial decorators and builders.

Technical data:

Dimensions (mm)	Ideal speed (rpm)	Maximum speed (rpm)	Material thickness (mm)	Backing	Packaging unit	Article number
Ø 115	2,000-4,500	5,000	13	Hook & loop	5	80901
Ø 150	2,000-4,000	5,000	13	Hook & loop	5	80900



Suitable for

ALUMINIUM · NON-FERROUS METALS

FIX AluPolish

Special soft fleece material for fine grinding (pre-polishing) aluminium and soft metals to a perfect mirror finish. Used without pastes or cremes. Removes fine scratches and leaves no smears on aluminium.



Technical data:

Dimensions (mm)	Ideal speed (rpm)	Maximum speed (rpm)	Backing	Packaging unit	Grit (fleece)	Article number
Ø 115	2,000-3,000	4,000	Hook & loop	10	very fine	80680
Ø 150	2,000-3,000	3,000	Hook & loop	10	very fine	80690



FIX HOOK & LOOP COMPLETE SYSTEM

Suitable for

STEEL · STAINLESS STEEL · NON-FERROUS METALS · WOOD · HARD PLASTICS

FIX SC Fleece



Technical surface conditioning fleece ideally suited to deburring, fine grinding, and **removing oxide layers**.

The newly developed **1FOR2 SC fleece fabric** (green) **includes ceramic grit** that allows **weld seams and spot welds to be removed** with a fine finish and clean, soft grinding transitions.

Technical data:

Dimensions (mm)	Ideal speed (rpm)	Maximum speed (rpm)	Approved for (DIN EN 13743)	Material	Backing	Pkg. unit	Grit (K)	Colour (fleece)	Grit (fleece)	Article number
Ø 100	5,000-8,000	12,000	63 m/sec	SC nylon fleece with reinforcing fabric	Hook & loop	10	80	brown	coarse	80605
							180	red	medium	80606
							280	blue	fine	80607
Ø 115	4,000-7,000	10,500	63 m/sec	SC nylon fleece with reinforcing fabric	Hook & loop	10	40	green	1FOR2 extra-coarse	80613
							80	brown	coarse	80615
							180	red	medium	80616
							280	blue	fine	80617
							400	grey	very fine	80618
Ø 125	4,000-6,000	9,600	63 m/sec	SC nylon fleece with reinforcing fabric	Hook & loop	10	40	green	1FOR2 extra-coarse	80624
							80	brown	coarse	80625
							180	red	medium	80626
							280	blue	fine	80627
Ø 150	3,000-5,000	8,000	63 m/sec	SC nylon fleece with reinforcing fabric	Hook & loop	10	40	green	1FOR2 extra-coarse	80649
							80	brown	coarse	80650
							180	red	medium	80651
							280	blue	fine	80652
							400	grey	very fine	80653
Ø 178	2,000-4,000	6,700	63 m/sec	SC nylon fleece with reinforcing fabric	Hook & loop	10	80	brown	coarse	80670
							180	red	medium	80671
							280	blue	fine	80672



Suitable for

STEEL · STAINLESS STEEL

FIX Trizact™ Disc

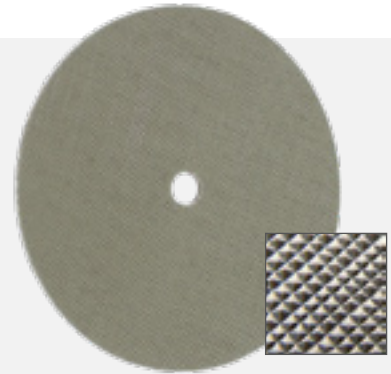

New type of **abrasive cloth** with **pyramid-shaped grit structure** and additional **heat-insulating layer**. **Saves** on several **operating steps** and has high material removal with very **fine results while removing scratches and spot welds**. Ideal pre-polishing for subsequent mirror-finish polishing. Leaves **very minor surface roughness**.

Technical data:

Dimensions (mm)	Ideal speed (rpm)	Maximum speed (rpm)	Approved for (DIN EN 13743)	Backing	Pkg. unit	Grit (Trizact™)	Grit (K)	Material removal (like approx. K)	Article number
Ø 115	4,000-6,000	10,500	63 m/sec	Hook & loop	10	A160	120	24	80930
						A100	220	36	80931
						A65	280	40	80932
						A45	400	50	80940
						A30	600	60	80960
						A16	1200	80	80970
						A06	2000	120	80980
Ø 150	3,000-5,000	8,000	63 m/sec	Hook & loop	10	A160	120	24	80983
						A100	220	36	80984
						A65	280	40	80985
						A45	400	50	80986
						A30	600	60	80987
						A16	1200	80	80988
						A06	2000	120	80989



FIX HOOK & LOOP COMPLETE SYSTEM

Suitable for

ALL METALS

FIX BRIGHTEX® Berry & Sun Disc



Polishing material that is already impregnated with **BRIGHTEX® polishing paste** removes the time-consuming hassle of applying pastes and creams to give untreated metal a **shadow-free mirror finish**.

FEATURES

Step 1: BRIGHTEX® Berry (pre-polishing):

- For applying a rapid high-gloss polish to all metals.
- Pre-polish and main polish in one – save on additional operations.

Step 2: BRIGHTEX® Sun (main polish):

- A mirror finish that's almost like chrome plating – perfect finish.
- For a final high-gloss shine on polished metals.
- For removing any residual clouding and smears from all metals.

• Please Note:

After changing pastes, always remove the polish residue from the workpiece! As necessary, the backing can be rewetted with BRIGHTEX® pastes.

- For reconditioning high-gloss surfaces which have been polished mechanically.
- Ideal for use with polishing machines and hand-held polishing tools.
- For the best results, use **Eisenblätter care and cleaning products** for removing polish residues (BRIGHTEX® Softclean Powder, Power Cleaner).
- With centring hole for backing pads with centring pins.
- Completely new **high-tech paste formulation** for metals.
- For immediate use without additional pastes and creams!

Technical data:

Dimensions (mm)	Version	Application	Material thickness (mm)	Ideal speed (rpm)	Maximum speed (rpm)	Backing	Pkg. unit	Article number
Ø 115	Berry (pink)	High-gloss polishing	5	2,500-3,500	10,500	Hook & loop	10	80718
Ø 125		High-gloss polishing	5	2,000-3,000	9,600	Hook & loop	10	80728
Ø 150		High-gloss polishing	5	2,000-2,500	8,000	Hook & loop	10	80753
Ø 178		High-gloss polishing	5	2,000	6,700	Hook & loop	10	80773
Ø 115	Sun (yellow)	Mirror-finish polishing	5	2,500-3,500	10,500	Hook & loop	10	80719
Ø 125		Mirror-finish polishing	5	2,000-3,000	9,600	Hook & loop	10	80729
Ø 150		Mirror-finish polishing	5	2,000-2,500	8,000	Hook & loop	10	80754
Ø 178		Mirror-finish polishing	5	2,000	6,700	Hook & loop	10	80774



Suitable for

ALL METALS

FIX SuperPolish Disc



Revolutionary special fleece. Used with polishing pastes and creams for a shiny mirror finish on stainless steel and non-ferrous metals which leaves no smears or shadows. **Please Note:** Always use a separate SuperPolish disc for each paste and cream – it is important not to mix different grit sizes.

Technical data:

Dimensions (mm)	Ideal speed (rpm)	Maximum speed (rpm)	Material thickness (mm)	Backing	Packaging unit	Article number
Ø 115	3,000-6,000	10,500	5	Hook & loop	10	80715n
Ø 125	3,000-6,000	9,600	5	Hook & loop	10	80725n
Ø 150	2,000-5,000	8,000	5	Hook & loop	10	80750n
Ø 178	2,000-5,000	6,700	5	Hook & loop	10	80770n



Suitable for

ALUMINIUM · NON-FERROUS METALS · HARD PLASTICS

FIX Felt Disc

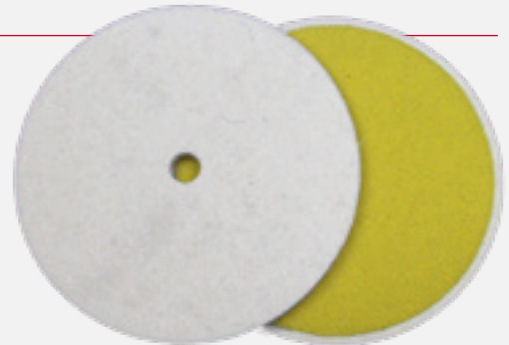

First-class Merino felt for rapid mirror finish using polishing pastes and creams that leave no scratches or smears. **Please Note:** Always use a separate felt disc for each paste and cream – it is important not to mix different grit sizes.

Technical data:

Dimensions (mm)	Ideal speed (rpm)	Maximum speed (rpm)	Material thickness (mm)	Material	Backing	Packaging unit	Article number
Ø 100	3,000-6,000	12,000	5	Merino felt	Hook & loop	10	80705
Ø 115	3,000-6,000	10,500	5	Merino felt	Hook & loop	10	80715
Ø 125	3,000-6,000	9,600	5	Merino felt	Hook & loop	10	80725
Ø 150	2,000-5,000	8,000	5	Merino felt	Hook & loop	10	80750
Ø 178	2,000-5,000	6,700	5	Merino felt	Hook & loop	10	80770



MULTI MAX[®]

The all-in-one work station

The extremely durable three-phase motor will become a fixed component of your workshop. Can also be used with many tools as a drive motor for flexible shafts with M14 threads.



FEATURES

- **Two shaft mounts for grinding discs** (such as flap discs) for angle grinders and **grinding rollers** for linear grinding machines.
- Can be used with the sophisticated FIX HOOK & LOOP quick-change system.
- **Powerful, efficient three-phase motor with 750-watt output** and very high torque.
- Fixed speed of 2,800 rpm.
- **Transparent, folding grinding guard** (to protect against flying sparks and dust).
- Roller support for precision work on the grinding wheel side.
- **Adjustable support rail with protective cover** for grinding discs of up to Ø 180 mm.
- **Drive motor for flexible shaft** for grinding and polishing with shaft tools.
- **Saves energy** and has a much lower noise level than stationary belt grinding machines.



Technical data MULTI MAX® machine

Dimensions (mm)	Plug type	Mains connection (V ~ Hz)	Power (W)	Speed (rpm)	Weight (kg)	Packaging unit	Article number
385 x 325 x 660	3-phase	380 ~ 50	750	2,800	23	1	30404

Set contents: 1 MULTI MAX® machine, 1 ROLEI Flat flap disc (Ø 170 mm), 1 protective cover for discs of up to Ø 180 mm



Interchangeable flexible shaft for grinding and polishing work on cumbersome workpieces.
SEE PAGES 153.

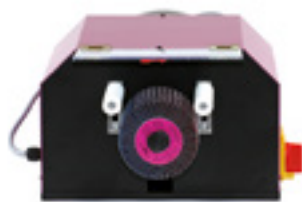

Shaft mount for all tools in the POLY-PTX® system (with 19-mm double spline shaft).



M14 mount for grinding discs with 22 mm bore (such as flap discs and polishing discs).



Uses the practical FIX HOOK & LOOP quick-change system.
SEE PAGES 142.

MULTI MAX[®] Professional Set

The all-in-one work station



For quick deburring, trimming, grinding, brushing, polishing, etc.

POLY-PTX[®] grinding rollers for linear grinding, matt finishing, and polishing, and grinding discs for circular grinding and fine grinding. FIX HOOK & LOOP system for circular grinding, polishing, and much more included in the set.

Technical data:

Dimensions (mm)	Plug type	Mains connection (V ~ Hz)	Power (W)	Speed (rpm)	Packaging unit	Article number
385 x 325 x 660	3-phase	380 ~ 50	750	2,800	1	30400

Set contents:

1 MULTI MAX[®] machine, 380 V

Circular grinding:

- 1 special adhesive backing plate Ø 150 mm
- 4 FIX HOOK & LOOP zirconium discs
- 2 FIX HOOK & LOOP flap discs
- 2 FIX HOOK & LOOP SC fleece discs
- 1 flat flap disc, Ø 170 mm
- 1 protective cover, Ø 180 mm

Linear grinding:

- 1 fleece wheel, Ø 115 x 110 mm
- 2 flap wheels, Ø 105 mm x 50 mm
- 1 mix wheel, Ø 115 x 100 mm
- 1 spacer ring set



Flexible Shaft

Now there's an even wider range of applications for the versatile MULTI MAX[®] mini workshop. The new flexible drive shaft with its sturdy 7-mm core and interchangeable M14 thread allows the machine to be upgraded to a professional drive motor.

The MULTI MAX[®] gives you a powerful professional motor for all applications. Ideal for 6 mm shaft tools. With an adapter for polishing rings of up to Ø 150 mm. Can also be used with variable-speed angle grinders such as VARILEX[®] 1802 HT, VARILEX[®] 1800, VARILEX[®] 1000, and VARILEX[®] 900 Duo.



Technical data:

Length (mm)	Collet (mm)	Mount	Maximum speed (rpm)	Can be used with (Ø mm)	Can be used with an adapter (for polishing rings, Ø mm)	Packaging unit	Article number
1,420	6	M14 thread	12,000	up to 75	up to 150	1	10014



MULTI MAX[®] Machine Stand

Sturdy steel machine stand with black powder coating. Delivery includes nuts and bolts for securing the machine. For working safely in a standing position.

Technical data:

Dimensions (L x W x H) (mm)	Weight (kg)	Packaging unit	Article number
400 x 350 x 830	20	1	30420



Streak-free hand-held satin finish!

LINEAR GRINDING – SATIN FINISHING



LINEAR GRINDING – SATIN FINISHING

SECTION HIGHLIGHTS 156

POWER TOOLS 158

NEW POLY-PTX® 802 HT	158
NEW POLY-PTX® AKKU HT	162
NEW POLY-PTX® AKKU HT accessories	164
NEW POLY-PTX® accessory sets	166
NEW POLY-PTX® 802 HT accessories	169
POLY-PTX® 800	170
POLY-PTX® 800 professional set	172
POLY-PTX® 800 accessories	173

GRINDING AND BLENDING 176

Ceramic sleeve	176
Zirconium sleeve	177
Trizact™ sleeve	178
EISENBLÄTTER quality – balancing	179
Flap wheel	180
Gum wheel	180
NEW Cut & Polish fleece wheel (S/C)	181
NEW CERAMIC flap wheel	182
NEW CERAMIC mix wheel	183

FINISHING AND FINE GRINDING 184

SC fleece sleeve	184
Mix wheel	185
Fleece wheel	186
Fleece Top wheel	187
NEW Scrubby wheel	187
Eco Smart adapter	188
Eco Smart flap wheel	189
Eco Smart mix wheel	190
Eco Smart fleece wheel	191

POLISHING 192

BRIGHTEX® Berry & Sun polishing sleeve	192
SuperPolish sleeve	193
Felt sleeve	193
Felt wheel	194
Cotton ring	194
Mirror finishing ring, medium	195
Mirror finishing ring, soft	195
BRIGHTEX® high-performance polishing pastes	196
BRIGHTEX® Softclean Powder	197
BRIGHTEX® microfibre cloths	197
NEW Power Cleaner	198
Polishing pastes (Classic)	198
Pink polishing cream	198

CLEANING 199

NEW CLEAN-MIX wheel	199
Clean wheel	200
Clean wheel soft	201

TECHNICAL BRUSHES 202

Wire wheel	202
Stainless steel wire wheel	202
Bristle wheel	203
Fibre wheel	203

PIPE MACHINING 204

POLY-PTX® grinding belt roller	204
POLY-PTX® special adhesive tape	205
High-quality corundum grinding belt	205
Trizact™ belt	206
SC fleece belt (T-lock)	207
BRIGHTEX® Berry & Sun polishing belts	208
SuperPolish belts	209
Felt belt (T-lock)	209

POWER TOOLS



POLY-PTX® 802 HT p. 158

POLY-PTX® AKKU HT p. 162

158

GRINDING AND BLENDING

Trizact™ sleeve p. 178

CERAMIC mix wheel p. 183



Zirconium sleeve p. 177



CERAMIC flap wheel p. 182



176

FINISHING AND FINE GRINDING

Mix wheel p. 185

Eco Smart system p. 188



SC fleece sleeve p. 184



Fleece wheel p. 186



184

POLISHING

SuperPolish sleeve p. 193

Mirror finishing ring, soft p. 195



BRIGHTEX® polishing sleeve p. 192

Felt sleeve p. 193

192

CLEANING

Clean wheel, soft p. 201

TECHNICAL BRUSHES

Bristle wheel p. 203



CLEAN-MIX wheel p. 199

Wire wheel p. 202

199

202

PIPE MACHINING

High-quality corundum grinding belt p. 205

SC fleece belt (T-lock) p. 207



POLY-PTX® grinding belt roller p. 204

BRIGHTEX® polishing belts p. 208

204

POLY-PTX[®] 802 HT

NEW

THE NEW STAYING POWER

The inventor of the hand-held linear grinding machine is introducing a refinement of its familiar POLY-PTX[®] series, starting immediately.

The new POLY-PTX[®] 802 HT (high torque) linear grinder offers a torque and performance profile that is so far unmatched. The newly developed planetary gear distributes traction across additional gear wheels in a sophisticated arrangement, greatly increasing all drive components' resistance to wear and making the professional device a continuous runner. Eisenblätter has also refined the shaft handle, offering it with new, rubberised inserts that provide an especially good grip and optimal handling during linear grinding, satin finishing, or polishing, ensuring uniform grinding results that are entirely free of shadows.

The drive spindle is of corrosion-free stainless steel. All grinding tools can be manually attached without screws by means of a self-centring knurled screw – now with rotary protection. Even the protective cover for the grinding rollers has been significantly improved and is of robust, precise aluminium pressure casting to which the optional suction cover with its suction sockets can be added. Special attention has been paid to the hose guide, which provides free lateral space during work. An additional retractable polycarbonate cover protects the eyes from flying particles during use of the extra-wide grinding rollers (up to 150 mm) from our Eco Smart system.

The new POLY-PTX[®] 802 HT has been designed for long service life and value preservation and represents a new level of quality and performance in linear grinding machines.

NEW 1,750-WATT MOTOR – EVEN MORE POWER

A refined motor with very high power density and a number of new features ensures completely new standards of torque, productivity, and service life.



POWER TRANSMISSION WITH A PLANETARY GEAR

A high-quality planetary gear has been designed for grinding machines in the low speed range. It ensures wear-resistant power transmission with enormous additional torque.





**POLY-PTX® CAN BE DELIVERED
AS A BATTERY-POWERED TOOL!**

See pages 162–163

THE NEW POLY-PTX® 802 HT ALLOWS YOU TO ACHIEVE CONVINCING PRODUCTION INCREASES AND VALUE PRESERVATION WITH VERY LOW FOLLOW-ON COSTS. IT IS OPTIMALLY EQUIPPED FOR TOUGH CONTINUOUS OPERATION.

DUST PREVENT SYSTEM FROM EISENBLÄTTER

The new DUST PREVENT SYSTEM (patent pending) effectively provides protection from coarse swarf and metal particles without impairing the cooling ventilation. A protective cap effectively reduces dust entering the lateral ventilation grilles. Particles bounce off the protective cap. Fresh air intake is only from the air in the rear, which is largely free of particles.

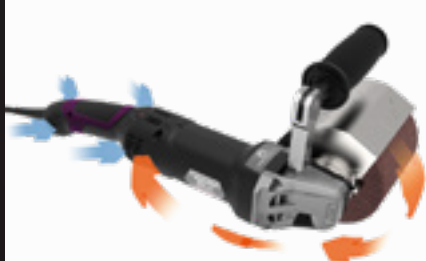

Without DUST PREVENT SYSTEM:

Coarse dust particles are taken into the ventilation grilles without any intervening protection.

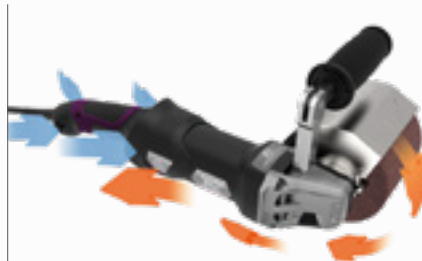

With DUST PREVENT SYSTEM:

Coarse dust particles bounce off the protective cap, and air with few particles is taken in from the rear.



Alternative:

For particulate matter (with aluminium, etc.), we recommend, as an alternative to the DUST PREVENT SYSTEM, the particulate matter protection cap (see page 29).

POLY-PTX[®] 802 HT

THE NEW STAYING POWER

OVERVIEW OF PRODUCT ADVANTAGES

- **Shadow-free satin finishing, brushing, polishing of all metals (stainless steel to non-ferrous metals) to wood.**
- Removes weld seams, deep scratches, rust, dirt, paint, and oxide layers.
- **Extremely powerful, durable motor of 1,750 W with a sophisticated planetary gear** for maximum power transmission and torque (high torque) throughout the **speed range, 820-3,000 rpm** with a tacho-generator for constant speeds, even under load – made entirely in Germany.
- New, especially **ergonomic shaft handle** for optimal grinding roller handling.
- **Planetary gear delivers maximum torque and preserves value.**
- 19 mm **stainless steel drive shaft with double splines** across the entire length of the spindle for grinding rollers of up to 115 mm in diameter and 100 mm working width (milled fleece wheels of up to 110 mm) – with the Eco Smart adapter, up to 150 mm working width.
- **Large grinding tool range** for decorative surface finishing.
- Very fine grinding on large surface areas thanks to the oscillating grinding movement.
- The **optional grinding belt roller** allows use as a **pipe grinder**, even on closed pipe constructions.



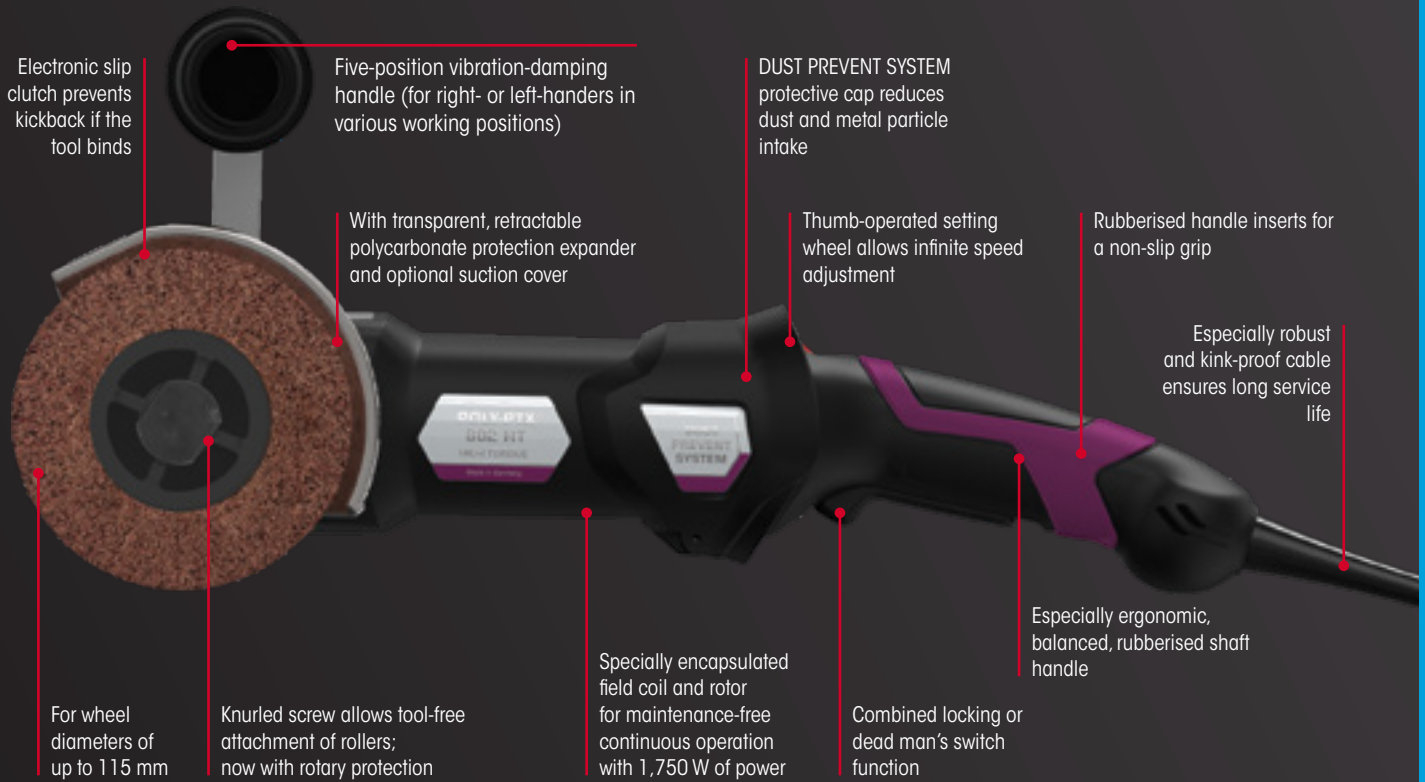

Optional ball joint mount for stationary fixing on workbenches, etc. (see p. 289)



Optional: Suction cover with optimised hose guide

Technical data **POLY-PTX® 802 HT basic set**

Plug type	Cable type	Mains connection (V ~ Hz)	Power (W)	Mount (mm)	Working width (mm)	Speed (rpm)	Weight (kg)	Pkg. unit	Article number
EU (C+F)	Permanent connection	220-240 ~ 50-60	1,750	19 mm Double keyway	max. 100 (with Eco Smart 150)	820-3,000	2.8	1	40201
CH (J)	Permanent connection	220-240 ~ 50-60	1,750	19 mm Double keyway	max. 100 (with Eco Smart 150)	820-3,000	2.8	1	40201s
US (B)	Permanent connection	110-120 ~ 50-60	1,750	19 mm Double keyway	max. 100 (with Eco Smart 150)	820-3,000	2.8	1	40201u
UK (G)	Permanent connection	110-120 ~ 50-60	1,750	19 mm Double keyway	max. 100 (with Eco Smart 150)	820-3,000	2.8	1	40201a
JP (B)	Permanent connection	110-120 ~ 50-60	1,750	19 mm Double keyway	max. 100 (with Eco Smart 150)	820-3,000	2.8	1	40201j



- Set contents:**
- 1 POLY-PTX® 802 HT machine
 - 1 DUST PREVENT SYSTEM
 - 1 particulate matter protection cap
 - 1 robust, impact-resistant plastic case for machine and accessories
 - 1 new POLY-PTX® tightening screw
 - 1 fleece wheel
 - 1 expansion roller
 - 1 zirconium sleeve
 - 1 SC fleece sleeve

Please Note: For practical accessory sets, see page 166.

POLY-PTX[®] AKKU HT

NEW

HIGH PULLING POWER



LINEAR GRINDING – SATIN FINISHING



OVERVIEW OF PRODUCT ADVANTAGES

- **Shadow-free satin finishing, brushing, polishing of all metals (stainless steel to non-ferrous metals) to wood.**
- **18-volt professional linear grinding machine.**
- Removes weld seams, deep scratches, rust, dirt, paint, and oxide layers.
- **Balanced, straight-line control** without support rollers. This allows the tool to be freely adjusted (oscillation effect), ensuring highly decorative surfaces in satin and matt finish and industrial grinding without shadows or transitions.
- **Available for the first time with planetary gear**, giving it the power of a plug-in machine of ~1,600 watts.
- **Robust cast aluminium protective cover** and vibration-damping, multi-adjustable handle.
- All **LiHD batteries** have LED charge indicators.
- **Top-performance 5.5 Ah** (optional **8.0 Ah**) batteries, can be rotated to **three positions by up to 270°** for convenient handling.
- New **CAS** (Cordless Alliance System) battery interface: compatible with a number of drive units and makes available on the market. Dual utility and savings potential of your battery pack included – see page 15.
- **The grinding belt roller allows ideal use as a pipe grinder.**
- A **“T-lock system”** for **pipe machining** ensures safe, fast connection of fleece and felt belts to **closed pipe constructions**. No more hassle having to glue the belts.

The new linear grinding machine with POLY-PTX® AKKU HT (High Torque) represents a novelty in the area of battery-powered, hand-held grinding machines. For the first time, a sophisticated planetary gear has been developed for linear grinding applications, exhibiting an unprecedented torque for driving all accessories, such as grinding rollers, brushes, expansion rollers, and much more – almost like a cable-bound, mains-driven linear grinder. The planetary gear's multiple sprockets allow increased output at the drive shaft that was previously unknown in this area. This enormous pulling power in a machine of very small size and weight is a global sensation and allows trade professionals entirely new capabilities on construction sites and in industrial operations that place special importance on cable-free work areas.

All familiar operations can now be performed cordlessly. The machine offers a constant speed of 1,600 rpm. This is ideally suited to most tools, such as fleece, mix, and flap wheels, expansion rollers with sleeves, brushes, and much more. An optional grinding belt roller also makes it suitable for pipe machining. The complete accessories for conventional linear grinders such as POLY-PTX® 802 HT can be used cordlessly with the revolutionary POLY-PTX® AKKU HT. The use of replaceable batteries allows the device to be employed for long periods of time. The batteries' LED charge indicators allow you to keep track of how much charge you have left. The drive shaft is made of corrosion-free stainless steel with the familiar double splines, usable with all Eisenblätter tools.

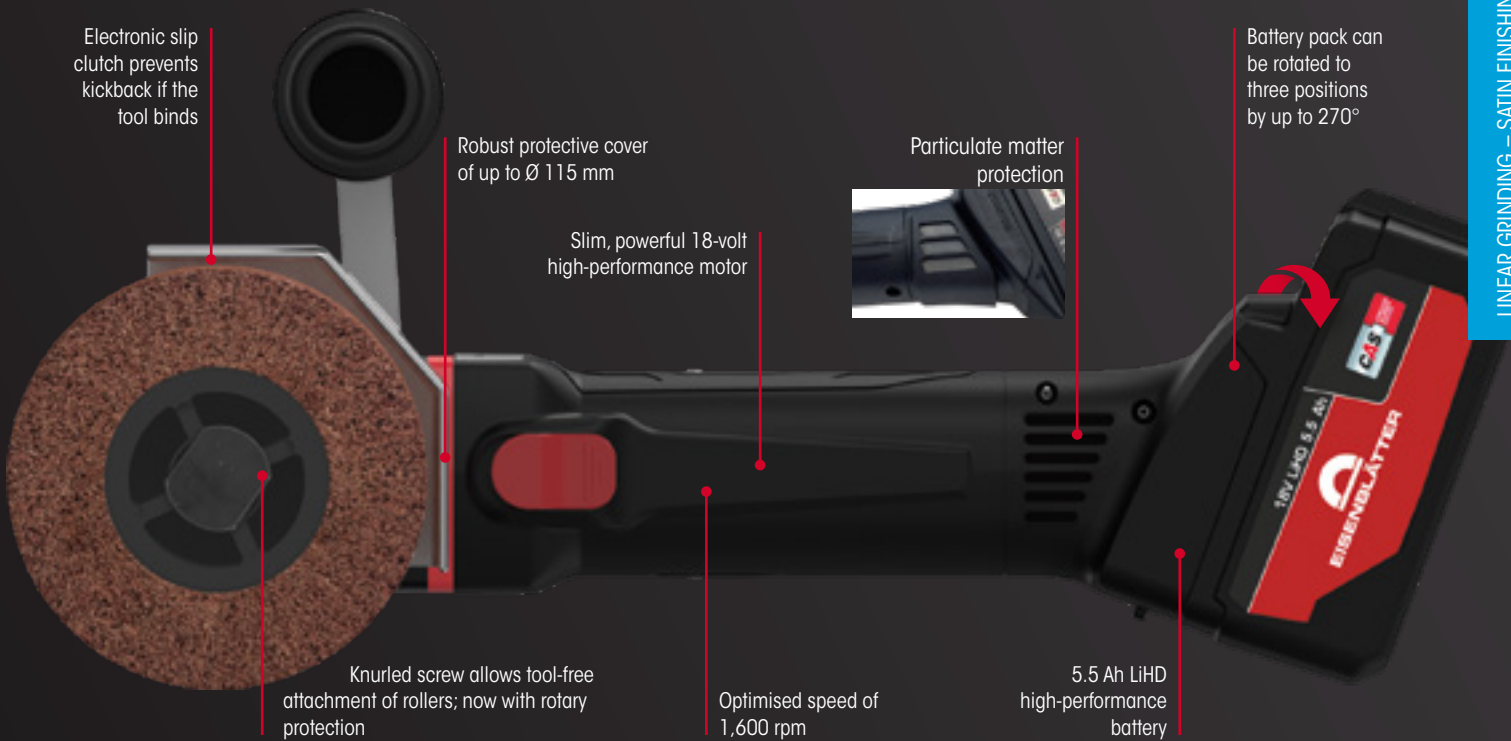

LINEAR GRINDING – SATIN FINISHING

Technical data POLY-PTX® AKKU HT basic set

Plug type	Cable type	Mains connection (V ~ Hz)	Power (V)	Mount	Working width (mm)	Speed (rpm)	Weight (kg)	Pkg. unit	Article number
EU (C+F)	Permanent connection	220-240 ~ 50-60	18	19 mm double keyway	max. 100	1,600	3.0	1	40301



- Set contents:**
- 1 POLY-PTX® AKKU HT machine, 18 volts
 - 1 robust, impact-resistant plastic case for machine and accessories
 - 1 particulate matter protection battery
 - 2 18-volt batteries with 5.5 Ah capacity
 - 1 charger, 220-240 volts
 - 1 cast aluminium protective cover for wheels of up to Ø 115 mm
 - 1 new POLY-PTX® tightening screw
 - 1 spacer ring set
 - 1 fleece wheel
 - 1 expansion roller
 - 1 zirconium sleeve
 - 1 SC fleece sleeve

Please Note: For practical accessory sets, see page 166.

POWER TOOLS

CORDLESS ALLIANCE SYSTEM

Suitable for

ALL CORDLESS ALLIANCE BATTERIES



High-speed Charging Device

NEW



For quick charging of all sliding-fit Li-ion and LiHD battery packs from 14.4 to 36 volts.

FEATURES

- **Patented "AIR COOLED" charging technology:** Batteries are cooled during charging for a much shorter charging time.
- High charging current ensures that the **battery packs are charged quickly.**
- Very **low stand-by power consumption.**
- Maximum charging current: 6.5 A.
- **Process-controlled charge management** for gentle charging and the greatest possible number of charging cycles.
- One charger for charging all battery packs from our CAS partner: www.cordless-alliance-system.de

Technical data:

Plug type	Cable type	Mains connection (V ~ Hz)	Maximum charging current (A)	Pkg. unit	Article number
EU (C+F)	Permanent connection	220-240 ~ 50-60	6.5	1	50474

Suitable for

ALL CORDLESS ALLIANCE SYSTEM DEVICES



5.5/8.0 Ah Battery

NEW



18 volts, LiHD technology

Powerful high-tech 18-volt battery (LiHD) for all battery-powered tools in the CAS group.

Technical data:

Article	Power (V)	Battery capacity (Ah)	Suitable for	Weight (kg)	Pkg. unit	Article number
5.5 Ah CAS battery	18	5.5	CAS devices	0.89	1	50463
8.0 Ah CAS battery	18	8.0	CAS devices	0.98	1	50473



Suitable for

ALL METALS

NEW

POLY-PTX® Accessory Set



The POLY-PTX® accessory set means that the right tools are always handy – in the workshop and on-site. The ideal addition to the set for metal finishing from coarse grinding to fine grinding. Ready for most standard sheet metal working and pipe machining, including many accessory parts (no machine).

Technical data:

Function	Can be used with:	Pkg. unit	Article number
Coarse grinding to satin finish	POLY-PTX® 802 HT, POLY-PTX® AKKU HT, POLY-PTX® 800	1	40202

Contents:

- 1 mobile tool case
- 6 POLY-PTX® zirconium sleeve
- 2 POLY-PTX® SC fleece sleeve
- 1 POLY-PTX® flap wheel
- 1 POLY-PTX® mix wheel
- 1 POLY-PTX® grinding belt roller
- 4 POLY-PTX® high-quality corundum grinding belts
- 1 POLY-PTX® special adhesive tape
- 1 POLY-PTX® SC fleece belt
- 1 POLY-PTX® spacer ring set
- 1 BRIGHTEX® microfibre cloth
- 1 BRILLIANCE CLEAN 50 ml
- 1 Power Cleaner 50 ml
- 1 INOX PROTECT 50 ml

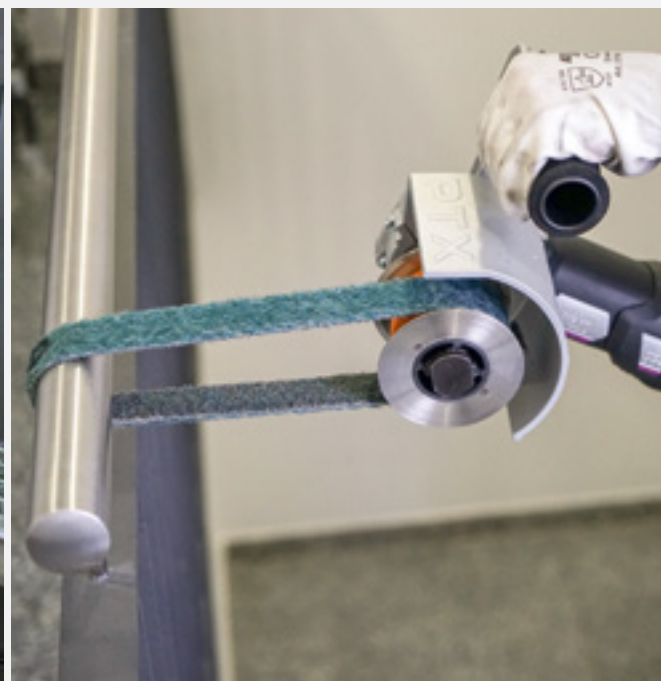

NEW

Suitable for

ALL METALS

POLY-PTX® Professional Complete Accessory Set



The POLY-PTX® 802 HT professional accessory set means that the right tools are always handy – in the workshop and on-site. This high-quality professional set in a lockable, stable, impact-resistant carrying case ensures that you have everything for shadow-free industrial grinding for perfect mirror finishes on metals (surfaces and pipes), and the newly developed cleaning and preserving agents for optimal surface protection against spots and fingerprints, ready to hand (without the machine).

Technical data:

Function	Can be used with:	Pkg. unit	Article number
Coarse grinding to a mirror finish	POLY-PTX® 802 HT, POLY-PTX® AKKU HT, POLY-PTX® 800	1	40203

Contents:

- | | | |
|---|---|---|
| 1 professional carrying case (survival) | 2 BRIGHTEX® microfibre cloths | 1 POLY-PTX® flap wheel |
| 1 POLY-PTX® spacer ring set | 1 BRIGHTEX® Softclean Powder | 1 POLY-PTX® grinding belt roller |
| 1 BRIGHTEX® Berry pre-polishing paste | 1 POLY-PTX® zirconium sleeve | 2 POLY-PTX® grinding belts |
| 1 BRIGHTEX® Sun post-polishing paste | 1 POLY-PTX® SC fleece sleeve | 1 POLY-PTX® SC fleece belt |
| 1 Power Cleaner 50 ml | 6 POLY-PTX® Trizact™ sleeves | 6 POLY-PTX® Trizact™ belts |
| 1 BRILLIANCE CLEAN 500 ml | 2 POLY-PTX® BRIGHTEX® Berry polishing sleeves | 2 POLY-PTX® BRIGHTEX® Berry polishing belts |
| 1 INOX PROTECT 500 ml | 2 POLY-PTX® BRIGHTEX® Sun polishing sleeves | 2 POLY-PTX® BRIGHTEX® Sun polishing belts |



NEW

Suitable for

WOOD

POLY-PTX® 802 HT Wood Accessory Set



The POLY-PTX® 802 HT wood accessory set means that the right tools are always handy – in the workshop and on-site. This set includes an additional Eco Smart adapter and contains everything you need for a brushed and rustic effect on wood surfaces and for polishing wax stains (without the machine).

Technical data:

Function	Can be used with:	Pkg. unit	Article number
Rustic effects, wax stain polishing	POLY-PTX® 802 HT	1	40204

Contents:

- 1 Suction cover for dust intake
- 1 spacer ring set
- 1 mix wheel Ø 115 x 100 mm
- 1 bristle wheel Ø 100 x 70 mm
- 1 bristle wheel Ø 100 x 25 mm
- 1 bristle wheel Ø 100 x 12 mm
- 1 wire wheel Ø 100 x 70 mm
- 1 wire wheel Ø 100 x 25 mm
- 1 fibre wheel Ø 100 x 100 mm



Working with wood:

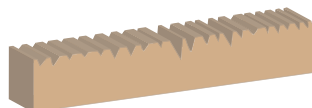

In combination with the wire wheel, the POLY-PTX® 802 HT is eminently suitable for brushing out soft growth rings in coniferous woods. A coarse rustic effect is easy to produce due to the materials used (wire brush for steel).

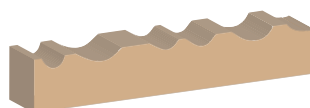

Used with the bristle wheel, a flexible, grit-impregnated plastic brush, the POLY-PTX® 802 HT is the ideal tool for producing a rustic effect with a soft growth ring transition.

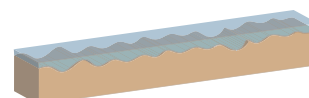

The fibre wheel guarantees stained wood surfaces are polished simply and yet with a top-quality finish. The flexible fibre brush guarantees a perfect matt sheen effect and is ideal for pore-deep cleaning and removal of dust.

NEW

Suitable for

POLY-PTX® 802 HT

POLY-PTX® 802 HT Suction Cover

for operations that generate lots of dust

Aluminium suction cover encloses the POLY-PTX® 802 HT protective cover laterally. For connecting to any commonly available industrial extractor. The new special hose guide allows workpieces to be machined all the way to the corners. Ideal for jobs that generate a great deal of dust (such as machining aluminium or wood). Usable with rollers up to 100 mm wide, delivery includes fixing bolts for mounting on an existing POLY-PTX® 802 HT protective cover.



Technical data:

Usable for roller widths of up to (mm)	Suitable for	Connection dimensions		Pkg. unit	Article number
		Exterior connection (mm)	Interior connection (mm)		
100	POLY-PTX® 802 HT	40	35	1	40205



Plastic Spacer Ring Set

For width adjustment on 19-mm double spline shafts for brushes, rollers, polishing rings, etc.

Contents:

- 2 units, 20 mm wide
- 1 unit, 10 mm wide
- 1 unit, 50 mm wide

Technical data:

Material	Packaging unit	Article number
Hard plastic	1	40007

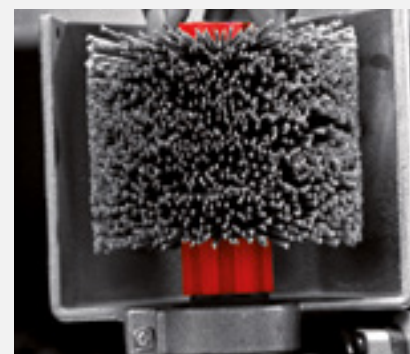

LINEAR GRINDING – SATIN FINISHING

Suitable for

LINEAR GRINDING · POLISHING

POLY-PTX[®] 800



From the inventor of the linear grinding machine. Our variable-speed, multipurpose linear grinder with 1,750 watts of power output and an ergonomic design is extremely versatile – even for working widths of up to 150 mm. High torque and power reserves guarantee professional continuous operation and improved economy.

FEATURES

- Grinding, **from coarse to fine.**
- **Balanced, straight-line control** without support rollers. This allows free adjustment (oscillation effect). Ensures highly decorative surfaces in satin and matt finish and industrial grinding without shadows or transitions.
- **Produces a satin finish, polishes to a mirror finish,** and improves surface finish on stainless steel, steel, and non-ferrous metals – brass, bronze, copper, aluminium, etc. – and wood.
- **Very fine grinding on large surface areas – with no shadows or streaks.**
- Removes weld seams, deep scratches, rust, dirt, paint, and oxide layers.
- **Just three steps from coarse grinding to a mirror finish** on stainless steel and non-ferrous metals.
- **The grinding belt roller allows ideal use as a pipe grinder.**
- Grinds and polishes **open and closed pipe constructions.**
- A **“T-lock system”** for **pipe machining** ensures safe, fast connection of fleece and felt belts to closed pipe constructions. No more hassle having to glue the belts.
- **Huge range of grinding tools** to cover almost any conceivable job.
- With a **rubberised handle for excellent control!**



Technical data POLY-PTX® 800 machine

Plug type	Cable type	Power (W)	Mains connection (V - Hz)	Speed (rpm)	Mount	Working width (mm)	Roller diameter (mm)	Weight (kg)	Pkg. unit	Article number
EU (C+F)	QUICK-LOCK	1,750	220-240 ~ 50-60	1,000-3,800	19 mm (double keyway)	max. 100 (with Eco Smart 150)	max. 115	3.3	1	40002
CH (J)	QUICK-LOCK	1,750	220-240 ~ 50-60	1,000-3,800				3.3	1	40002s

Delivery scope: 1 POLY-PTX® 800 machine, 1 QUICK-LOCK cable (4 m), 1 POLY-PTX® tightening screw, 1 fleece wheel (115 x 100 x 19 mm)

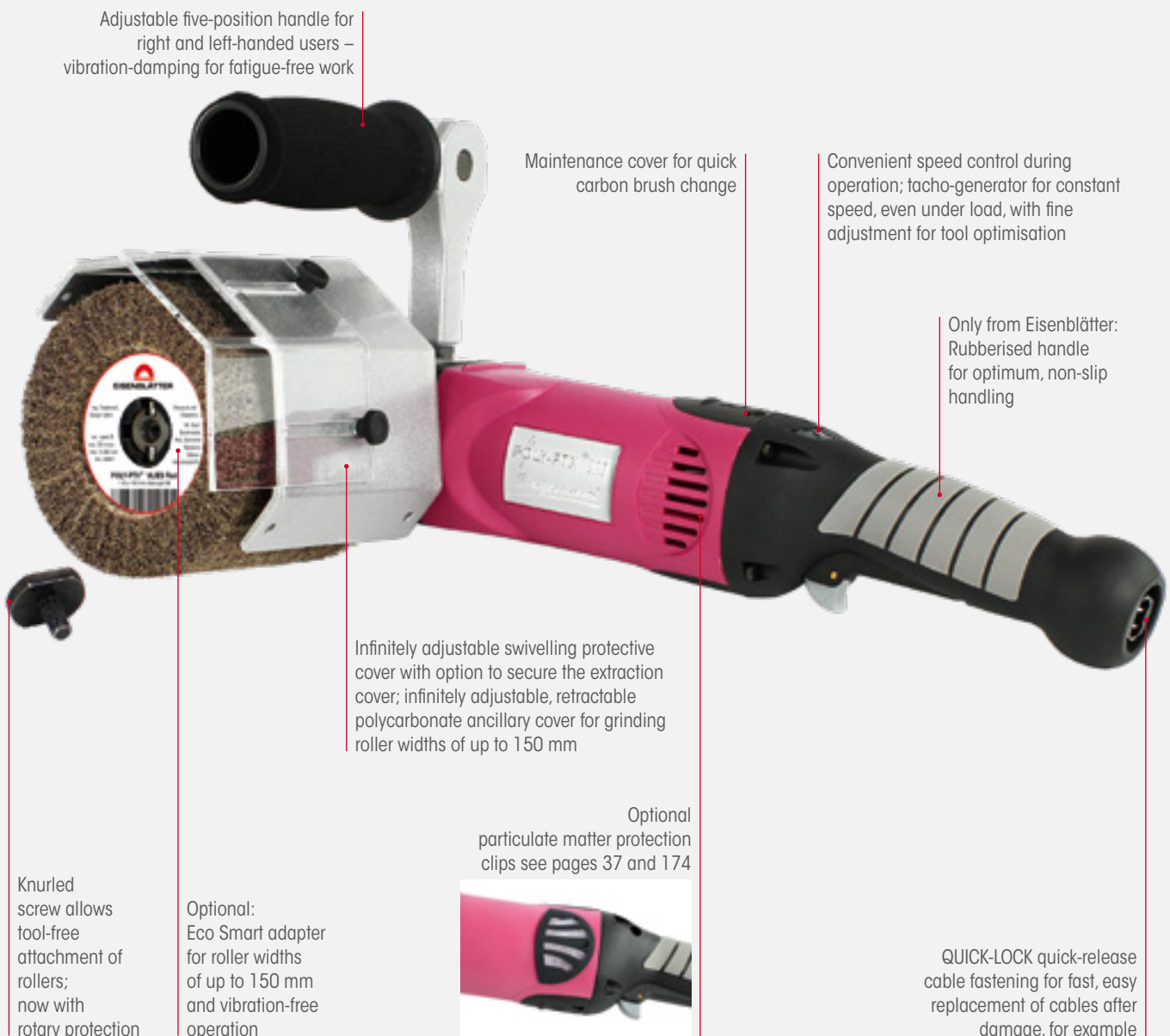

Suitable for

COARSE GRINDING TO A MIRROR FINISH

POLY-PTX[®] 800 Professional Set



Complete solution for varied tasks

The POLY-PTX[®] 800 professional set means that the right tools are always handy – in the workshop and on-site. This set, consisting of the machine and an Eco Smart adapter in a practical, stable, impact-resistant carrying case ensures that you have everything for shadow-free industrial grinding for perfect mirror finishes on metals (surfaces and pipes), and the cleaning and preserving agents for optimal surface protection against spots and fingerprints, ready to hand. (Machine included in delivery.)

Technical data:

Plug type	Cable type	Power (W)	Mains connection (V – Hz)	Speed (rpm)	Mount	Working width (mm)	Roller diameter (mm)	Pkg. unit	Article number
EU (C+F)	QUICK-LOCK	1,750	220-240 ~ 50-60	1,000-3,800	19 mm (double keyway)	up to 100 (with Eco Smart 150)	up to 115	1	40003-5
CH (J)	QUICK-LOCK	1,750	220-240 ~ 50-60	1,000-3,800				1	40003-5s

Set contents:

- 1 POLY-PTX[®] 800 machine
- 1 professional carrying case (survival)
- 1 QUICK-LOCK cable (4 m)
- 1 spacer ring set
- 1 Eco Smart adapter
- 1 mini-tube of high-gloss pink polishing cream
- 2 White and blue mini polishing paste
- 1 BRIGHTEX[®] Softclean Powder
- 1 BRILLIANCE CLEAN 500 ml
- 1 INOX PROTECT 500 ml
- 2 BRIGHTEX[®] microfibre cloths

Linear grinding:

- 1 expansion roller
- 2 zirconium sleeves
- 2 SC fleece sleeves
- 8 Trizact[™] sleeves
- 3 SuperPolish sleeves
- 1 flap wheel
- 1 fleece wheel
- 8 Top Finish rings

Pipe machining:

- 1 grinding belt roller
- 2 grinding belts
- 1 SC fleece belt
- 8 Trizact[™] belts
- 3 SuperPolish belts

QUICK-LOCK Cable

Suitable for VARILEX® WSF 900, 1600 & 1800, POLY-PTX® 300, 500 & 800, ROLEI EF 115, PIPE MAX, PIPE SNIPER, and GLADIUS® 1800.

Technical data:

Version	Cable length (m)	Voltage (V)	Packaging unit	Article number
EU (C+F)	4	220-240	1	52004-3
EU (C+F)	10	220-240	1	52005-3
CH (J)	4	220-240	1	52004-3s
AU	4	220-240	1	52004-3a
UK (G)	4	110	1	52004-3e
US (B)	4	120	1	52004-3u
Plug adapter – EU to UK	4		1	52004d



POLY-PTX® 800 Aluminium Suction Cover

The aluminium suction cover encloses the POLY-PTX® 800 protective cover laterally. For connecting to any commonly available industrial extractor. The new parallel hose guide allows workpieces to be machined all the way to the corners.

Ideal for jobs that generate a great deal of dust (such as machining aluminium or wood).

Delivery includes fixing bolts for mounting on an existing POLY-PTX® 800 protective cover.

Technical data:

Connection dimensions		Suitable for	Can be used with rollers of up to (mm)	Pkg. unit	Article number
Exterior connection (mm)	Interior connection (mm)				
40	35	POLY-PTX® 800	100	1	40005



Particulate Matter Protection Clips

Greatly reduces the risk of an electronic short circuit due to metal dust

The new dust protection clips prevent fine dust and contamination particles from entering the machine’s interior and thus increase its service life. The breathable filter fleece is easy to replace – if necessary, the operation takes a few seconds. Just remove the dust protection clip from the machine, replace the dirty filter fleece with a new one, and mount it on the machine’s air intake slots, where it will lock.

NEW



Technical data:

Contents	Can be used with:	Pkg. unit	Article number
2 clips and 22 filter fleeces	POLY-PTX® 300/500/800, VARILEX® 1600/1800, PIPE MAX, PIPE SNIPER, GLADIUS® 1800, ROLEI EF 115	1	40085



Suitable for

PERFECT MITRE GRINDING

Stainless Steel Cover Plate

Stainless steel cover plate produces precision mitre edges and easy cutting with shears.

Clean adhesion for perfect mitre grinding on all materials. Self-adhesive, can be removed without leaving any residue – easy control without rework guaranteed.



YOU CAN FIND MORE DETAILS ON PAGE 286.

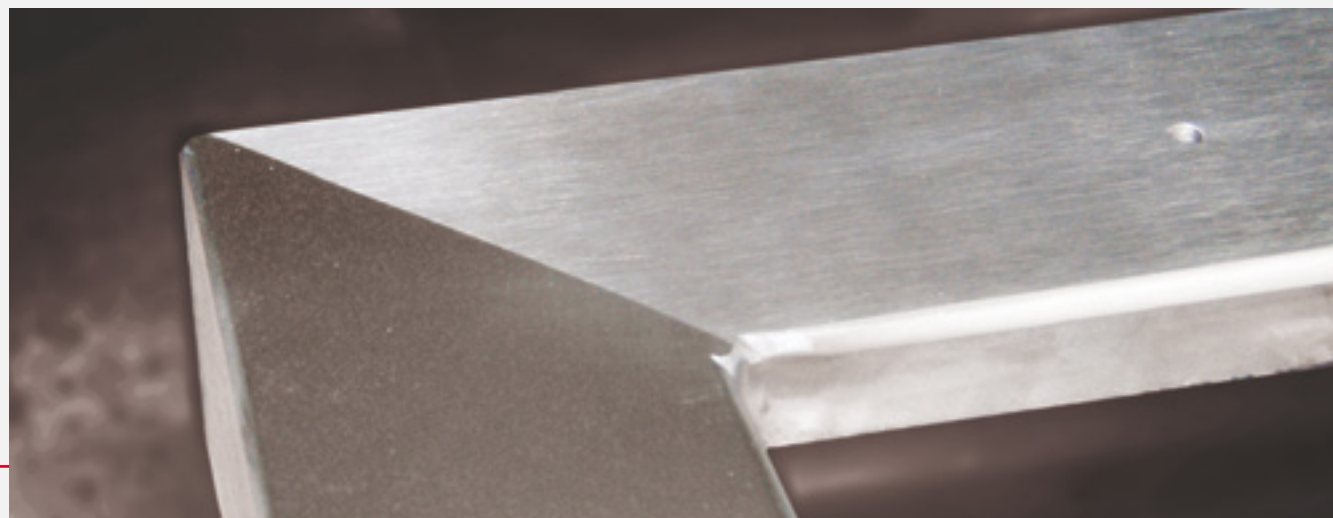

Suitable for

SLEEVES Ø 90 mm

POLY-PTX[®] Expansion Roller



The patented triple-segment expansion roller is a special innovation. It ensures optimum adjustment to the workpiece, improving all grinding and polishing results. Changing the sleeve is particularly easy with the patented triple-segment system.

Technical data:

Dimensions (Diameter x width x drill bore in mm)	Maximum speed (rpm)	Packaging unit	Article number
Ø 90 x 100 x 19	5,000	1	42002
Ø 90 x 50 x 19	5,000	1	42001

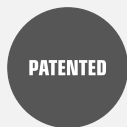

Suitable for

SLEEVES Ø 90 x 100 mm

POLY-PTX[®] Inflatable Expansion Roller



The **individual "hardness adjustment"** of the respective zirconium, ceramic, SC fleece, Trizact™, SuperPolish, BRIGHTEX®, and felt **sleeves** makes this inflatable expansion roller a good idea. It is particularly well-suited to grinding flat surfaces and edges. It can also be inflated with a bicycle pump or similar device (for individual pressure adjustment, adapter included).

Technical data:

Dimensions (Diameter x width x drill bore in mm)	Maximum speed (rpm)	Packaging unit	Article number
Ø 90 x 100 x 19	5,000	1	42003



Suitable for

ALL METALS

Ceramic Sleeve

Grinding sleeves made from high-quality ceramic cloth with a service life multiples of that of a conventional grinding sleeve. For removing deep scratches, rust, scale, and weld seams. Generates bright, strong surface structures (for the coarse decorative finish).

ONLY IN CONNECTION WITH AN EXPANSION ROLLER (SEE PAGES 175 AND FOLLOWING).



Technical data:

Dimensions (Diameter x width in mm)	Material	Packaging unit	Grit (K)	Article number
Ø 90 x 100	Ceramic cloth	10	40	42440
			60	42460
			80	42480

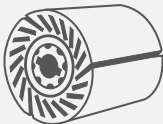

EISENBLÄTTER Ceramic self-sharpening process

The existing grinding force breaks off sintered microcrystals, continuously giving the grit new, sharp cutting edges.

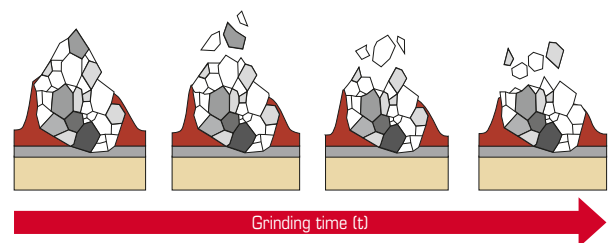

Suitable for

STEEL · STAINLESS STEEL

Zirconium Sleeve

Grinding sleeves of high-quality zirconium cloth for removing deep scratches, rust, scale, and weld seams (for a powerful line finish).

ONLY IN CONNECTION WITH AN EXPANSION ROLLER (SEE PAGES 175 AND FOLLOWING).



Technical data:

Dimensions (Diameter x width in mm)	Material	Packaging unit	Grit (K)	Article number
Ø 90 x 100	Zirconium cloth	10	40	42040
			60	42060
			80	42080
			120	42120
			150	42150
			180	42180
Ø 90 x 50	Zirconium cloth	10	40	42301
			60	42302
			80	42303
			120	42304
			150	42305
			180	42306

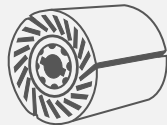

Suitable for

STEEL · STAINLESS STEEL

Trizact™ Sleeve

New type of **abrasive cloth** with **pyramid-shaped grit structure**. **Saves** on several **operating steps** and has high material removal with very **fine results while removing scratches and spot welds**. Ideal pre-polishing for subsequent mirror-finish polishing. Leaves **very minor surface roughness**.

ONLY IN CONNECTION WITH AN EXPANSION ROLLER (SEE PAGE 175).



Technical data:

Dimensions (Diameter x width in mm)	Packaging unit	Grit (Trizact™)	Grit (K)	Material removal (like approx. K)	Article number
Ø 90 x 100	10	A160	120	24	42280
		A100	220	36	42270
		A65	280	40	42265
		A45	400	50	42245
		A30	600	60	42230
		A16	1,200	80	42216
		A06	2,000	120	42206
Ø 90 x 50	10	A160	120	24	42327
		A100	220	36	42326
		A65	280	40	42325
		A45	400	50	42324
		A30	600	60	42323
		A16	1,200	80	42322
		A06	2,000	120	42321

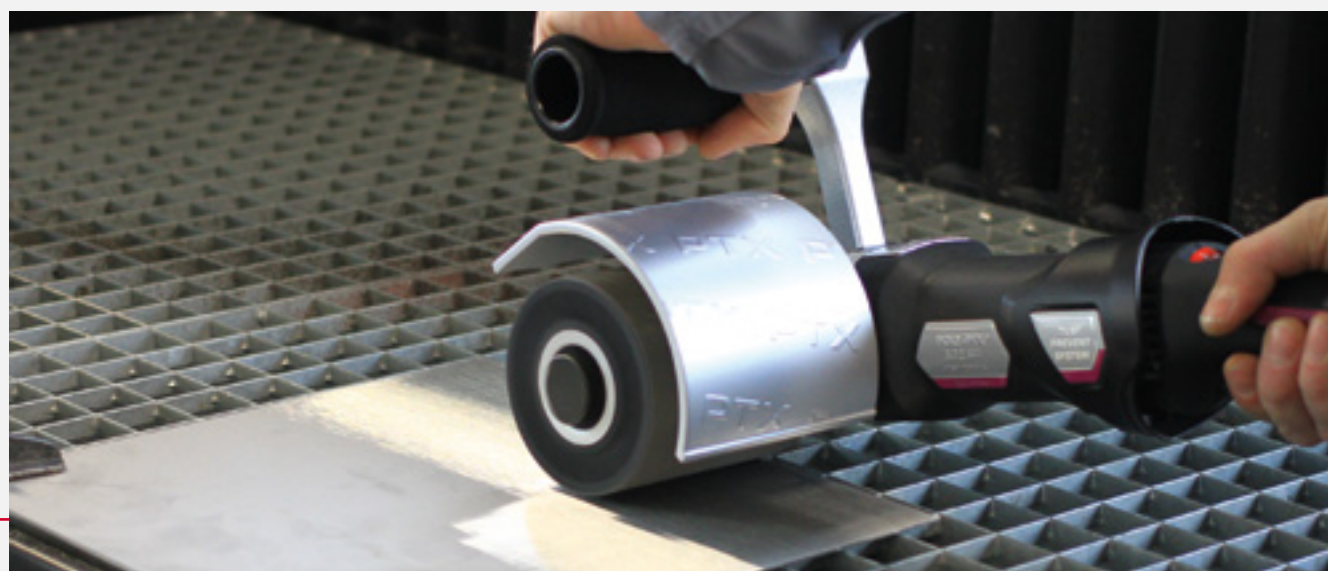
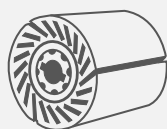

EISENBLÄTTER QUALITY

Balancing

The balancing process is used only on linear grinding rollers from Eisenblätter

The quality of the surface finish crucially depends on whether the grinding rollers run perfectly. The individual grinding rollers are often out of balance due to factors relating to production and raw materials which result in imbalance and vibration. This is transmitted to the workpiece, resulting in chatter marks and shadows and producing results that are not clean. Eisenblätter offers this exclusive advantage all over the world for a number of products.

Eisenblätter wheels are balanced with a machine designed specially for the purpose (similar to the machine used for car tyres). Imbalances are compensated for with counterweights.

The result: The roller rotates perfectly. This ensures high quality for grinding and satin finishing. Surfaces can be machined perfectly, and there is no costly, time-consuming rework as there is with grinding rollers that have not been balanced.



Balanced products are all marked with the 'Balanced' icon.



Suitable for

ALL METALS · WOOD

Flap Wheel

Abrasive flap wheel for surface grinding

For **removing rust, oxide layers, paint, and scratches** and for **satin finishing and applying strong structures** to metals. With a vibration-damping sleeve for single, double, and quadruple spline shafts, ensuring the wheel runs perfectly.



Technical data:

Dimensions (Diameter x width x drill bore in mm)	Ideal speed (rpm)	Maximum speed (rpm)	Material	Pkg. unit	Grit (K)	Article number
Ø 105 x 100 x 19	1,000-2,000	5,000	High-quality corundum cloth	4	40	41440
					60	41460
					80	41480
					120	41490
					180	41491
Ø 105 x 50 x 19	1,000-2,000	5,000	High-quality corundum cloth	4	24	41024
					40	41040
					60	41060
					80	41080
					120	41120
					180	41180
					240	41240

Suitable for

STEEL · STAINLESS STEEL · NON-FERROUS METALS

Gum Wheel

Especially **soft gum wheel** with silicon grit for **improved workpiece adjustment**. For **eliminating minor scratches** and **removing scale**.

The result is a brightly gleaming, powerfully textured **decorative linear grind** on stainless steel and non-ferrous metals. Also used for smoothing wood fibre.



Technical data:

Dimensions (Diameter x width x drill bore in mm)	Ideal speed (rpm)	Maximum speed (rpm)	Packaging unit	Grit (K)	Article number
Ø 105 x 100 x 19	1,000-2,000	2,000	2	60	45061
				180	45181
Ø 105 x 50 x 19	1,000-2,000	2,000	4	60	45060
				180	45180



Suitable for

STAINLESS STEEL · NON-FERROUS METALS

Cut & Polish Fleece Wheel (S/C)



The extremely high grit content combined with a silicon carbide grit mix allows this well-known satin finish (**industrial grinding K240-280**) to be achieved extremely quickly on stainless steel. A satin finish can be achieved without prep work **even on untreated, scratch-free stainless steel surfaces**.

Recommendation when there are scratches: Prep work with a 60 grit fleece wheel. **Oxide layers are quickly removed** by the high grit content. The bright finish produces a very **attractive effect**.

Technical data:

Dimensions (Diameter x width x drill bore in mm)	Ideal speed (rpm)	Maximum speed (rpm)	Material	Pkg. unit	Grit (K)	Article number
Ø 115 x 100 x 19	1,000-2,000	5,000	Silicon carbide fleece	2	240-280	43004



Generate an industrial finish without prep work – even scale is quickly removed.



NEW

Suitable for

ALL METALS

CERAMIC Flap Wheel

Powerful material removal with a decorative sheen effect



A newly developed ceramic abrasive flap wheel of ceramic grit ensures a **previously unachieved glossy look, especially on stainless steel**. The powerful, **high-gloss linear structures** allow completely new **decorative effects!**

Especially attractive for small visible surfaces. The ceramic grit has a significantly more aggressive impact and easily **removes scratches of medium severity** in a single work step. Can also be used for cleaning and removing rust and scale. The results come significantly quicker than with conventional flap wheels of aluminium oxide cloth. With a vibration-damping sleeve for single, double, and quadruple spline shafts, ensuring the wheel runs perfectly.

Technical data:

Dimensions (Diameter x width x drill bore in mm)	Ideal speed (rpm)	Maximum speed (rpm)	Material	Pkg. unit	Grit (K)	Article number
Ø 105 x 100 x 19	1,000-2,000	5,000	Ceramic cloth	4	40	41540
					60	41560
					80	41580

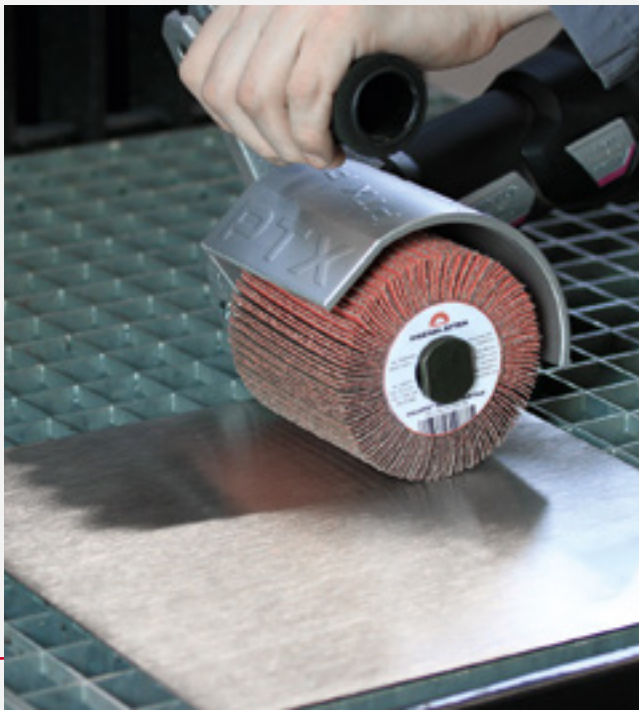

EISENBLÄTTER Ceramic self-sharpening process

The existing grinding force breaks off sintered microcrystals, continuously giving the grit new, sharp cutting edges.

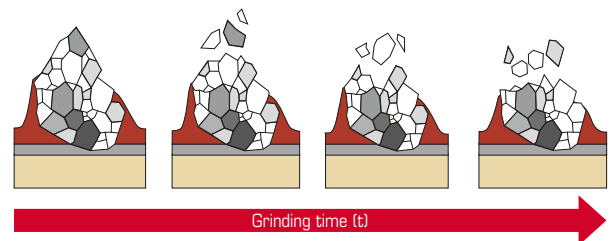

NEW

Suitable for

ALL METALS · WOOD

CERAMIC Mix Wheel

Remove scratches with a very attractive sheen effect



A completely new and **especially attractive surface appearance on stainless steel** can be achieved with this newly developed grinding roller. A special **ceramic flap formulation** was used, as was our refined fleece cloth with grit 60.

The wear behaviour between fleece and ceramic cloth is critical here if uniform grinding results are to be achieved over the grinding roller's service life.

The CERAMIC mix wheel meets these requirements and generates a previously unachieved, **glossy linear structure**, which achieves a special effect, especially on visible surfaces. The result is a lighter, slightly **glittering sheen**, completely without shadows. At the same time, minor damage to the sheet or **light scratches** are also **removed**. With a vibration-damping sleeve for single, double, and quadruple spline shafts, ensuring the wheel runs perfectly.

Technical data:

Dimensions (Diameter x width x drill bore in mm)	Ideal speed (rpm)	Maximum speed (rpm)	Material	Pkg. unit	Grit (K)	Article number
Ø 115 x 100 x 19	1,000-2,000	5,000	Ceramic cloth	4	60	44561

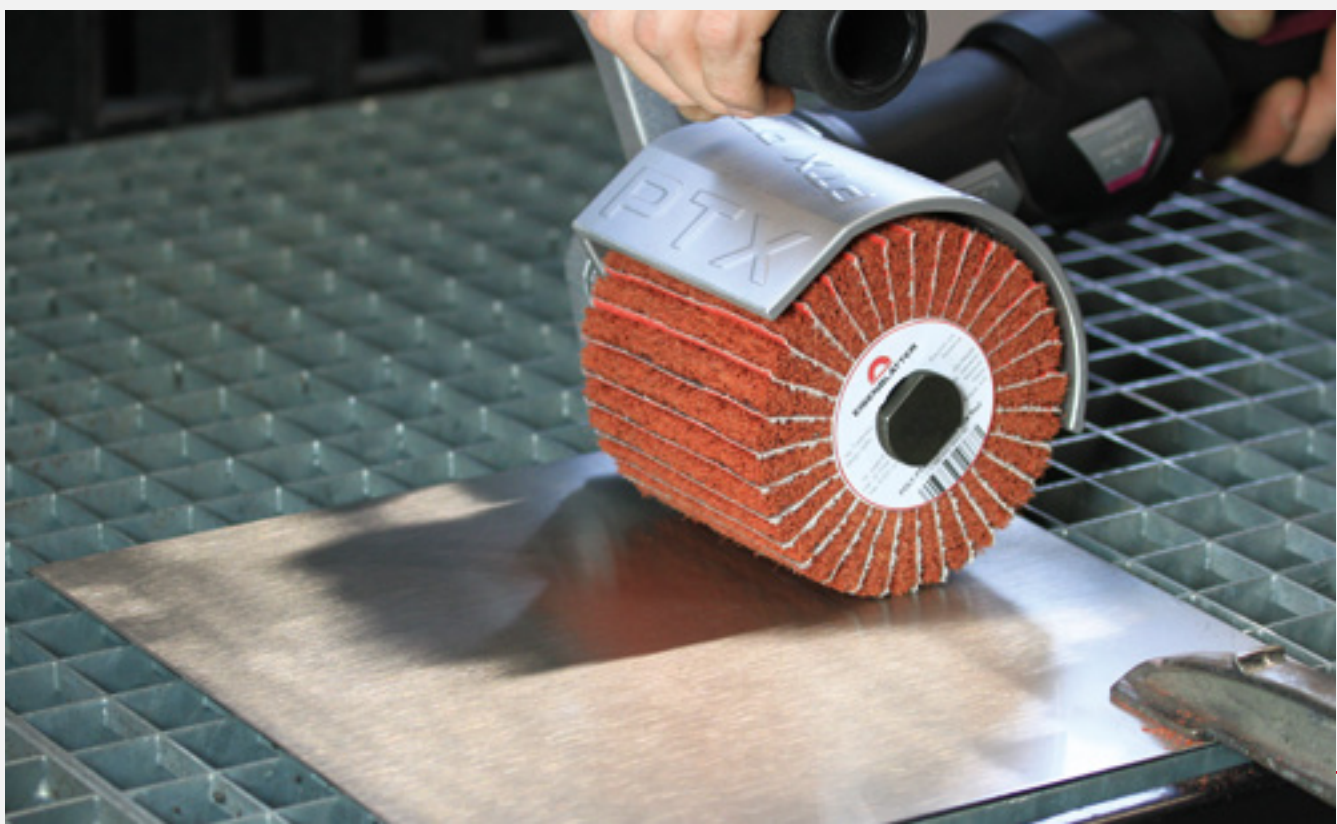

Suitable for

STEEL · STAINLESS STEEL · NON-FERROUS METALS · WOOD · HARD PLASTICS

SC Fleece Sleeve

Technical surface conditioning fleece ideally suited to deburring, fine grinding, and **removing oxide layers**. Also works very well for **decorative satin finishing and linear grinding** while removing minor scratches (you may want to do rework with a POLY-PTX® fleece wheel to neutralise grinding transitions).

ONLY IN CONNECTION WITH AN EXPANSION ROLLER (SEE PAGE 175).



Technical data:

Dimensions (Diameter x width in mm)	Material	Pkg. unit	Grit (K)	Colour (fleece)	Grit (fleece)	Article number
Ø 90 x 100	SC nylon fleece with reinforcing fabric	4	80	brown	coarse	42010
			180	red	medium	42011
			280	blue	fine	42012
			400	grey	very fine	42009
Ø 90 x 50	SC nylon fleece with reinforcing fabric	4	80	brown	coarse	42311
			180	red	medium	42312
			280	blue	fine	42313
			400	grey	very fine	42314



Suitable for

STEEL · STAINLESS STEEL · WOOD

Mix Wheel

Fleece abrasive flap combination wheel



High-quality grit-impregnated nylon fleece with versatile **high-quality corundum abrasive cloth** for uniform wear over its entire service life. It is more abrasive than pure fleece wheels. With a vibration-damping sleeve for single, double, and quadruple spline shafts, ensuring the wheel runs perfectly.

Metal: Matt finishing; satin finishing; removing minor scratches, oxide, and paint; etc.

Wood: Smoothing surfaces and removing old paint, dirt, etc.

Technical data:

Dimensions (Diameter x width x drill bore in mm)	Ideal speed (rpm)	Maximum speed (rpm)	Material	Pkg. unit	Grit (K)	Article number
Ø 115 x 100 x 19	1,000-2,000	5,000	High-quality corundum cloth	4	60	44061
					80	44101
					120	44121
					180	44181
Ø 115 x 50 x 19	1,000-2,000	5,000	High-quality corundum cloth	4	60	44060
					80	44100
					120	44120
					180	44180
Ø 105 x 100 x 19	1,000-2,000	5,000	High-quality corundum cloth	4	60	44061a
					80	44101a
					120	44121a
					180	44181a
Ø 105 x 50 x 19	1,000-2,000	5,000	High-quality corundum cloth	4	60	44060a
					80	44100a
					120	44120a
					180	44180a

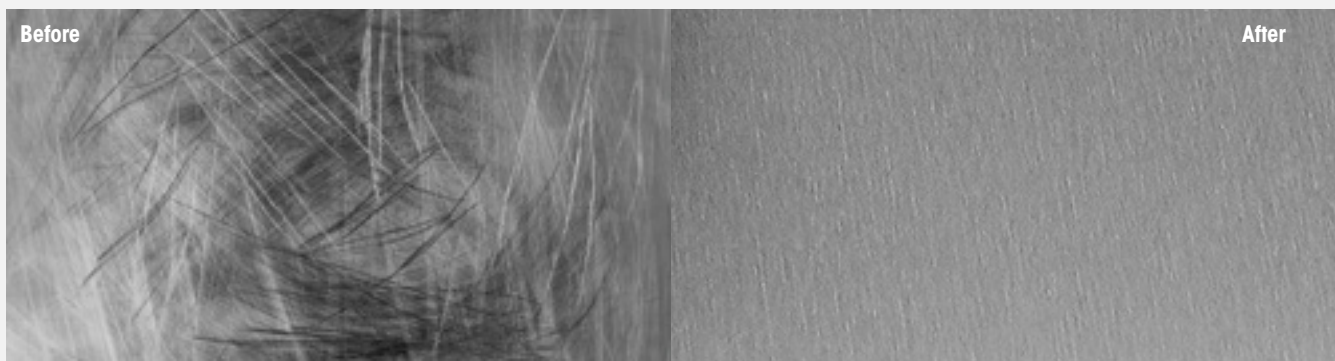

Suitable for

STAINLESS STEEL · NON-FERROUS METALS · WOOD

Fleece Wheel

Compact high-tech fleece wheel made from compressed nylon grit fleece for industrial grinding



Very **high-quality fleece fabric** for especially **long service life**. Generates a **shadow-free industrial finish** (matt finish, satin finish). Can also be used for pre-polishing, **removing oxide layers**, **blending "pre-ground" sheet metal**, and smoothing surfaces. With a vibration-damping sleeve for single, double, and quadruple spline shafts, ensuring the wheel runs perfectly. Provides the **option** of achieving a **working width of 110 mm** (fits all satin-finish tools) with 60, 80, and 180 grits and a diameter of **115 mm**. The tightening screw is sunk into the wheel, allowing grinding up to the edge.

Technical data:

Dimensions (Diameter x width x drill bore in mm)	Ideal speed (rpm)	Maximum speed (rpm)	Material	Pkg. unit	Grit (K)	Article number
Ø 115 x 110 x 19 (an extra 10 mm wide for corner grinding)	1,000-2,500	5,000	Nylon fleece fabric	4	60	43061
					80	43101
					180	43181
Ø 115 x 100 x 19	1,000-2,500	5,000	Nylon fleece fabric	4	60	43061c
					80	43101c
					180	43181c
					280	43281
					400	43401
					600	43601
					900	43901
Ø 115 x 50 x 19	1,000-2,500	5,000	Nylon fleece fabric	4	60	43060
					80	43100
					180	43180
					280	43280
					400	43400
					600	43600
Ø 105 x 100 x 19	1,000-2,500	5,000	Nylon fleece fabric	4	60	43061a
					80	43101a
					180	43181a
					280	43281a
					400	43401a
					600	43601a
Ø 105 x 50 x 19	1,000-2,500	5,000	Nylon fleece fabric	4	60	43060a
					80	43100a
					180	43180a
					280	43280a



Suitable for

ALL METALS · WOOD

Fleece Top Wheel

Fleece wheel compressed with polyurethane foam. **Multiple times the service life** of pure fleece wheels. **Generates strong linear structures with a decorative sheen** and performs fine deburring of **perforated sheet metal**. With a vibration-damping sleeve for single, double, and quadruple spline shafts, ensuring the wheel runs perfectly.



Technical data:

Dimensions (Diameter x width x drill bore in mm)	Ideal speed (rpm)	Maximum speed (rpm)	Material	Pkg. unit	Grit (K)	Article number
Ø 112 x 100 x 19	1,000-3,000	5,000	Foamed nylon fleece fabric	2	80	43102
					180	43103
					400	43105



Suitable for

ALL METALS · WOOD

Scrubby Wheel

The sophisticated solution for uneven surfaces



Highly flexible high-quality corundum wheel for abrasive cloth with flaps with multiple slits. For all sheet metal, including with punches and drill bores, it quickly produces linear grinding while deburring all punch or bore edges. The large number of pre-slitted cloth flaps mean that the individual flap sections are able to get perfectly into all uneven spots and round all interior edges.

This wheel can be used with many materials, such as steel, stainless steel, non-ferrous metals, hard plastics, and wood. With a vibration-damping core for single, double, and quadruple spline shafts, ensuring the wheel runs perfectly.

Technical data:

Dimensions (Diameter x width x drill bore in mm)	Ideal speed (rpm)	Maximum speed (rpm)	Material	Pkg. unit	Grit (K)	Article number
Ø 115 x 100 x 19	1,000-2,000	5,000	High-quality corundum	2	120	41314



GRINDING AND BLENDING

POLY-PTX® ECO SMART

Suitable for

ECO SMART TOOLS

POLY-PTX® Eco Smart Adapter

The fastest and cheapest mount for grinding rollers

The low-cost, innovative, **tool-free linear grinding quick-release system** for use on the 100 mm POLY-PTX® coupling shaft. Just push tool rollers onto the Eco Smart adapter – they will be fixed in place with the machine's running motions without any further effort. Whether the components are extra-wide rollers with a 150-mm working depth or narrow wheels with a 50-mm working depth – they will all be quickly and reliably fixed with the Eco Smart adapter. Wheels that are 50 mm wide can be fixed at any position on the shaft without spacer rings.



FEATURES

- Can be used with POLY-PTX® and all linear grinding machines with Ø 19 mm spline shaft.
- Innovative tool mount for quick roller change.
- The simple Eco Smart system can be used with Eco Smart tools such as **mix and fleece wheels** with working widths of up to 150 mm.
- Finned rigid rubber sleeve ensures completely **vibration-free work** and **keeps the tools running perfectly**.
- Simply slide the adapter onto the spline shaft and you're ready to use Eco Smart tools.
- Guarantees immediate, **secure fixing of tools**.

Technical data:

Dimensions (Diameter x width x drill bore in mm)	Maximum speed (rpm)	Packaging unit	Article number
Ø 45 x 100 x 19	6,000	1	42004

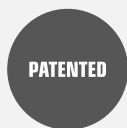

Simply mount the Eco Smart adapter on the linear grinding machine's Ø 19 mm spline shaft to start using Eco Smart tools.

The counter-rotating rubber flaps allow Eco Smart wheels to be secured in seconds without tools.



Suitable for

ALL METALS · WOOD

Eco Smart Flap Wheel

Abrasive flap wheel for surface grinding in the Eco Smart version (eliminating the cost of the inner core, inner sleeves, or cast resin) for **removing rust, oxide layers, and scratches** and for **applying a textured and satin finish on all metals**. **Easy-to-use quick-release function** for Eco Smart rollers in any position on the Eco Smart adapter.

ONLY IN CONNECTION WITH AN ECO SMART ADAPTER (SEE PAGE 188).



Technical data:

Dimensions (Diameter x width x drill bore in mm)	Material	Ideal speed (rpm)	Maximum speed (rpm)	Pkg. unit	Grit (K)	Article number
Ø 105 x 100 x 45	High-quality corundum cloth	1,000-2,000	5,000	4	40	47211
					60	47212
					80	47213
					120	47214
					180	47215
Ø 105 x 50 x 45	High-quality corundum cloth	1,000-2,000	5,000	4	40	47202
					60	47204
					80	47205
					120	47206
					180	47207

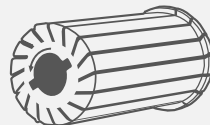
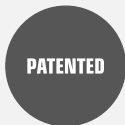

FINISHING AND FINE GRINDING

POLY-PTX® ECO SMART

Suitable for

STEEL · STAINLESS STEEL · WOOD

Eco Smart Mix Wheel

Fleece abrasive flap combination wheel

High-quality grit-impregnated nylon fleece with **high-quality corundum abrasive cloth** for uniform fleece and abrasive cloth wear in an Eco Smart design (eliminating costs for inner core, inner sleeves, or cast resin; working width of up to 150 mm). It is more abrasive than pure fleece wheels.

Metal: Matt finishing; satin finishing; removing minor scratches, oxide, and paint; etc.

Wood: Smoothing surfaces and removing old paint, dirt, etc.

ONLY IN CONNECTION WITH AN ECO SMART ADAPTER (SEE PAGE 188).



Technical data:

Dimensions (Diameter x width x drill bore in mm)	Ideal speed (rpm)	Maximum speed (rpm)	Material	Pkg. unit	Grit (K)	Article number
Ø 105 x 150 x 45	1,000-2,000	5,000	High-quality corundum cloth	2	80	47322
					180	47323
Ø 105 x 100 x 45	1,000-2,000	5,000	High-quality corundum cloth	4	60	47311
					80	47312
					180	47313
Ø 105 x 50 x 45	1,000-2,000	5,000	High-quality corundum cloth	4	60	47301
					80	47302
					180	47303



The Eco Smart system allows ideal grinding all the way to corners (sheet metal upstands) since all Eco Smart tools can be placed anywhere on the Eco Smart adapter without spacer rings.

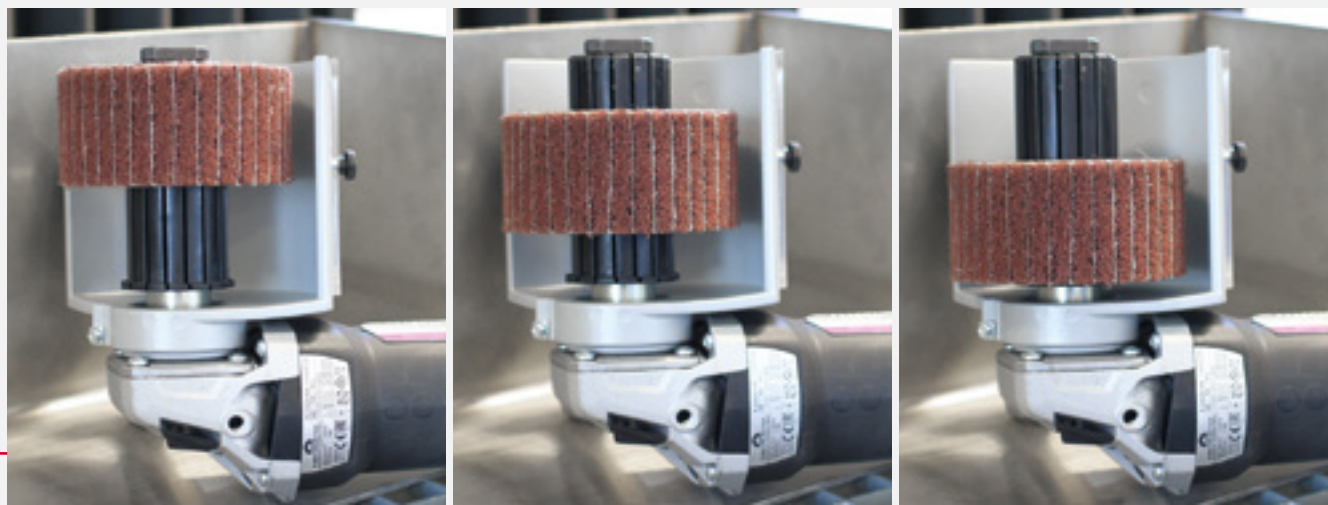

Suitable for

STAINLESS STEEL · NON-FERROUS METALS · WOOD

Eco Smart Fleece Wheel



Compact high-tech fleece wheel of compressed nylon grit fleece for an industrial finish

High-tech fleece wheel in an Eco Smart design (eliminating costs for inner core, inner sleeves, or cast resin; working width of up to 150 mm). Generates a **shadow-free industrial finish** (matt finish, satin finish). Can also be used for pre-polishing, removing oxide layers, **blending "pre-ground" sheet metal, and smoothing surfaces.**

CAN BE USED ONLY WITH THE ECO SMART ADAPTER (SEE PAGE 188).

Technical data:

Dimensions (Diameter x width x drill bore in mm)	Ideal speed (rpm)	Maximum speed (rpm)	Material	Pkg. unit	Grit (K)	Article number
Ø 105 x 150 x 45	1,000-2,000	5,000	Nylon fleece	2	80	47422
					180	47423
Ø 105 x 100 x 45	1,000-2,000	5,000	Nylon fleece	4	60	47411
					80	47412
					180	47413
					280	47414
					400	47415
Ø 105 x 50 x 45	1,000-2,000	5,000	Nylon fleece	4	80	47402
					180	47403
					280	47404

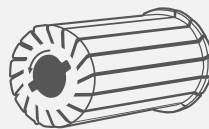

The Eco Smart system also allows working widths of up to 150 mm!



Suitable for

ALL METALS

BRIGHTEX® Polishing Sleeve

Berry & Sun



Polishing material that is already impregnated with **BRIGHTEX® polishing paste** removes the time-consuming hassle of applying pastes and creams to give untreated metal a **shadow-free mirror finish. For immediate use** without additional pastes and creams!

ONLY IN CONNECTION WITH AN EXPANSION ROLLER (SEE PAGE 175).

FEATURES

Step 1: BRIGHTEX® Berry (pre-polishing):

- For applying a rapid high-gloss polish to all metals.
- Pre-polish and main polish in one – save on additional operations.

Step 2: BRIGHTEX® Sun (main polish):

- A mirror finish that's almost like chrome plating – perfect finish!
- For a final high-gloss shine on polished metals.
- For removing any residual clouding and smears from all metals.
- **Please Note:**
After changing pastes, always remove the polish residue from the workpiece! As necessary, the backing can be rewetted with BRIGHTEX® pastes.

- For reconditioning high-gloss surfaces which have been polished mechanically.
- Ideal for use with polishing machines and hand-held polishing tools.
- For the best results, use **Eisenblätter care and cleaning products** for removing polish residues (BRIGHTEX® Softclean Powder, Power Cleaner).
- Completely new **high-tech paste formulation** for metals.
- For immediate use without additional pastes and creams!

Technical data:

Version	Dimensions (Diameter x width in mm)	Ideal speed (rpm)	Maximum speed (rpm)	Application	Pkg. unit	Article number
Berry (pink)	Ø 90 x 100	1,000-3,000	5,000	High-gloss polishing	2	42014
Berry (pink)	Ø 90 x 50	1,000-3,000	5,000	High-gloss polishing	4	42332
Sun (yellow)	Ø 90 x 100	1,000-3,000	5,000	Mirror-finish polishing	2	42015
Sun (yellow)	Ø 90 x 50	1,000-3,000	5,000	Mirror-finish polishing	4	42333



Suitable for

ALL METALS

SuperPolish Sleeve



Revolutionary special fleece. Used with polishing pastes and creams for a **shiny mirror finish** on stainless steel and non-ferrous metals which leaves **no smears or shadows**.

ONLY IN CONNECTION WITH AN EXPANSION ROLLER (SEE PAGE 175) AND POLISHING PASTES (SEE PAGES 196/198) OR CREMES (PAGE 198).

Please Note: Always use a separate sleeve for each paste and cream – it is important not to mix different grit sizes.

Technical data:

Dimensions (mm)	Material thickness (Diameter x width in mm)	Ideal speed (rpm)	Maximum speed (rpm)	Material	Pkg. unit	Article number
Ø 90 x 100	5	1,000-3,000	5,000	Polishing fleece	4	42013n
Ø 90 x 50	5	1,000-3,000	5,000	Polishing fleece	4	42331

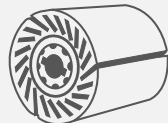

Suitable for

ALUMINIUM · NON-FERROUS METALS · HARD PLASTICS

Felt Sleeve



First-rate Merino felt sleeve, continuous throughout with no joins. For rapid mirror finish using polishing pastes and creams that leave no scratches or smears.

ONLY IN CONNECTION WITH AN EXPANSION ROLLER (SEE PAGE 175) AND POLISHING PASTES (SEE PAGES 196/198) OR CREMES (PAGE 198).

Please Note: Always use a separate felt disc for each paste and cream – it is important not to mix different grit sizes.

Technical data:

Dimensions (mm)	Material thickness (Diameter x width in mm)	Ideal speed (rpm)	Maximum speed (rpm)	Material	Pkg. unit	Article number
Ø 90 x 100	5	1,000-3,000	5,000	Merino felt	4	42013



Suitable for

ALUMINIUM · NON-FERROUS METALS · HARD PLASTICS

Felt Wheel

For **pre-polishing and high gloss polishing** of small to medium even surfaces, from non-ferrous metals to stainless steel. **First-class Merino felt wheel of continuous felt material** with a vibration-damping sleeve for single, double, and quadruple spline shafts; ensures that the wheel runs perfectly. Can be used with great contact pressure.

ONLY IN CONNECTION WITH POLISHING PASTES (SEE PAGES 196/198) OR CREMES (PAGE 198).

Please Note: Do not use different pastes or creams on the same felt wheel.



Technical data:

Dimensions (Diameter x width x drill bore in mm)	Material	Ideal speed (rpm)	Maximum speed (rpm)	Packaging unit	Article number
Ø 100 x 50 x 19	Merino felt	1,000-3,000	5,000	4	40017



Suitable for

NON-FERROUS METALS

Cotton Ring

Fine **cotton rings** for polishing. **Impregnated version for non-ferrous metals.** Ideal for **high-gloss polishing** of non-ferrous metals, such as aluminium and brass. Ideal for uneven workpieces and chequered plate. The spline shaft hole allows it to be slipped directly onto the POLY-PTX® 802 HT. Eight units fit perfectly on the 100-mm POLY-PTX® shaft.

ONLY IN CONNECTION WITH POLISHING PASTES (SEE PAGES 196/198) OR CREMES (PAGE 198).

Please Note: Do not use different pastes or creams on the same cotton ring.

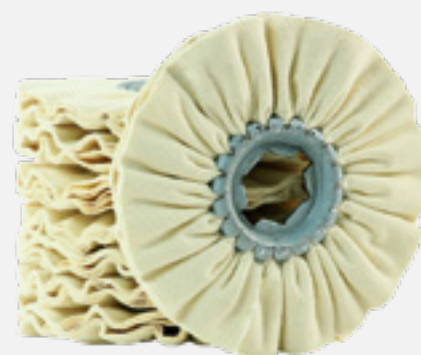

Technical data:

Dimensions (Diameter x width x drill bore in mm)	Material	Ideal speed (rpm)	Maximum speed (rpm)	Pkg. unit	Article number
Ø 100 x 10 x 19	Cotton ring (impregnated)	1,000-3,000	5,000	8	40019



Suitable for

STAINLESS STEEL

Mirror Finishing Ring, Medium



Fine polishing rings of technical fleece material, **impregnated for stainless steel**. For **main polish** on narrow or uneven stainless steel surfaces and chequered plate. The spline shaft hole allows it to be slipped directly onto the POLY-PTX® 802 HT. Eight units fit perfectly on the 100-mm POLY-PTX® shaft.

ONLY IN CONNECTION WITH POLISHING PASTES (SEE PAGES 196/198) OR CREMES (PAGE 198).

Please Note: Do not use different pastes or creams on the same mirror finishing ring.

Technical data:

Dimensions (Diameter x width x drill bore in mm)	Material	Ideal speed (rpm)	Maximum speed (rpm)	Pkg. unit	Article number
Ø 100 x 10 x 19	Technicaler fleece material (impregnated)	1,000-3,000	5,000	8	40019m



Suitable for

STAINLESS STEEL · NON-FERROUS METALS

Mirror Finishing Ring, Soft



Fine, soft polishing rings of technical fleece material. **Excellent mirror finishing effect** (final polish for metals from stainless steel to non-ferrous metals) with the same result as buff wheels. The spline shaft hole allows it to be slipped directly onto the POLY-PTX® 802 HT. Eight units fit perfectly on the 100-mm POLY-PTX® shaft.

ONLY IN CONNECTION WITH POLISHING PASTES (SEE PAGES 196/198) OR CREMES (PAGE 198).

Please Note: Do not use different pastes or creams on the same mirror finishing ring.

Technical data:

Dimensions (Diameter x width x drill bore in mm)	Material	Ideal speed (rpm)	Maximum speed (rpm)	Pkg. unit	Article number
Ø 100 x 10 x 19	Technicaler fleece material	1,000-3,000	5,000	8	40019t



Suitable for

ALL METALS

NEW FORMULATION

BRIGHTEX® High-performance Polishing Pastes

The fastest way to a mirror finish

For the first time, the **pre-polishing and main polishing steps can be completed with just one paste (BRIGHTEX® Berry)**! This has been made possible by a completely new formulation. For instance, stainless steel can be polished to a mirror finish in only a few moments. This saves **several working steps**. The yellow **BRIGHTEX® Sun paste** creates an **even brighter high gloss shine** – almost as if it's **chrome plated**. Both pastes can be used on SuperPolish discs and belts and on felt discs, belts, and sleeves. The pastes are applied to the polishing disc, belt, or sleeve while it is running at a low speed so that it is completely covered. This process can be repeated several times. The pastes can also be used for the new BRIGHTEX® polishing system (pre-impregnated polishing discs, belts, and sleeves) to “top up” the polishing fleeces as required.



FEATURES

Step 1: BRIGHTEX® Berry (pre-polishing):

- For applying a rapid high-gloss polish to all metals.
- Pre-polish and main polish in one – save on additional working steps.

Step 2: BRIGHTEX® Sun (main polish):

- A mirror finish that's almost like chrome plating – perfect finish.
- For a final high-gloss shine on polished metals.
- For removing any residual clouding and smears from all metals.
- **Please Note:**
After changing pastes, always remove the polish residue from the workpiece!

- For reconditioning high-gloss surfaces which have been polished mechanically.
- For use with felt, cotton, fleece discs, wheels, sleeves, belts, etc.
- Ideal for use with polishing machines and hand-held polishing tools (POLY-PTX®).
- For the best results, use Eisenblätter care and cleaning products to remove polish residues (BRIGHTEX® Softclean Powder, Power Cleaner).
- Completely new high-tech paste formulation for metals.

Technical data:

Paste	Contents (g)	Application	Packaging unit	Article number
BRIGHTEX® Berry pre- and main polish (pink)	about 1,100	High-gloss polishing	1	40025
BRIGHTEX® Berry mini paste (pink)	about 140	High-gloss polishing	1	40025m
BRIGHTEX® Sun post-polishing paste (yellow)	about 1,300	Mirror-finish polishing	1	40026
BRIGHTEX® Sun mini paste (yellow)	about 140	Mirror-finish polishing	1	40026m

Suitable for

ALL METALS

BRIGHTEX® Softclean Powder

A **new**, much improved **cleaning powder** removes all cream and paste residue after every polish, giving all metals a polished, completely scratch-free shine. Simply apply a little using the shaker, as you would powdered sugar, and wipe it off with a **clean microfibre cloth** without applying any pressure. The powder consists of **ultra-fine micro-particles** with a large surface area for the **best possible absorbency**.



Technical data:

Packaging	Contents (g)	Packaging unit	Article number
Resealable bag	about 1,000	1	40028
Aluminium shaker	about 200	1	40029

Suitable for

ALL MATERIALS

BRIGHTEX® Microfibre Cloths



Much improved, **ultra-soft microfibre cloth**, free of seams for completely **scratch-free cleaning** of **stainless steel surfaces** and other **decorative metals**. Particularly soft and absorbent. Can be washed repeatedly.

Technical data:

Dimensions (mm)	Quality	Packaging unit	Article number
400 x 400	360 g/m ²	5	40031



Suitable for

ALL METALS

Power Cleaner

Universal cleaner in its most environmentally-friendly form

Clean and preserve – especially for the removal of grease-based polish residue (BRIGHTEX® pastes).

YOU CAN FIND MORE DETAILS ON PAGE 276.

Technical data:

Packaging	Contents	Packaging unit	Article number
Spray bottle	50 ml	1	40057
	500 ml	1	40055
Can (including spray bottle)	5 litres	1	40056



Suitable for

ALL METALS

Polishing Pastes (Classic)

Mirror-finish polishing for all metals (including aluminium).

White for pre-polishing, blue for final polish.

Technical data:

Paste	Contents (g)	Pkg. unit	Article number
Pre-polishing paste (white)	about 650	1	40013
Polishing paste (blue)	about 650	1	40014
White and blue mini paste	approx. 120 (60 each)	1	40009



Suitable for

ALL METALS

Pink Polishing Cream

For final polishing, with Classic polishing pastes, for example, it produces a flawless mirror finish on all metals when applied with SuperPolish, felt, and polishing rings. Brings a quick shine – also suitable for manual application with polishing cloths. Ideal for moulded parts as well.

Technical data:

Packaging	Contents	Packaging unit	Article number
Can	about 1,000 g	1	40015
Mini-tube	approx. 60 ml	1	40015t



NEW

Suitable for

ALL METALS · WOOD

CLEAN-MIX Wheel

Cleaning wheel with intermediate abrasive flap layers for a quick cleaning effect and long service life



Newly designed **cleaning wheel with intermediate abrasive flap layers**. For an enhanced cleaning effect and longer service life. The stabilizing abrasive flaps prevent the CLEAN material from dissipating early.

The **improved grinding effect** thus achieved makes removing scales, rust, burrs, and paint **much more effective**.

The intermediate abrasive cloth layers wear uniformly with the cleaning fleece so that no disparities between the grinding components arise. The open, elastic cloth pores of the CLEAN material mean that **the product does not clog** and allows a **sand-blast-like effect on metal**.

Weld seams are made clean and bright, pore-deep. **Paint can be removed quickly** and effortlessly from wood, and weathered wooden beams or planks can be renewed in record time.

FEATURES

- **The quickest way to remove scales, rust, burrs, etc. from metals.**
- **Quick cleaning and renewing of metal and wooden surfaces.**
- The intermediate abrasive flap layers, tailored to the CLEAN material, ensure **uniform wear and therefore consistent grinding results.**
- With a vibration-damping sleeve for single, double, and quadruple spline shafts, ensuring the wheel runs perfectly.

Technical data:

Dimensions (Diameter x width x drill bore in mm)	Ideal speed (rpm)	Maximum speed (rpm)	Packaging unit	Article number
Ø 115 x 100 x 19	1,000-2,000	5,000	2	44018

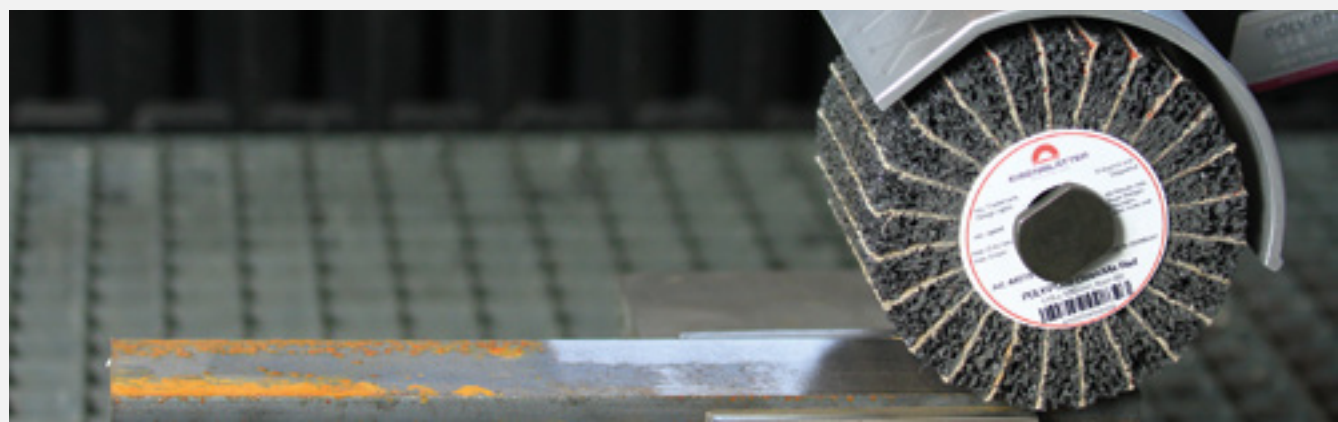

Suitable for

STEEL · STAINLESS STEEL · NON-FERROUS METALS · WOOD

POLY-PTX® Clean Wheel



Ultra-resistant nylon fleece cleaning wheel

Cleans and removes pore-deep paint, rust, scale, and dirt on all materials.

The effect is similar to that of sand-blasting: **cleans without removing material**. Ideal for car bodywork, the automotive industry, shipyards, and renovation work by commercial decorators and builders. At a width of 100 mm, the overhang provides a working width of 110 mm (fits all satin-finish tools). The tightening screw is sunk into the wheel, allowing grinding up to the edge. With a vibration-damping sleeve for single, double, and quadruple spline shafts, ensuring the wheel runs perfectly.

Technical data:

Dimensions (Diameter x width x drill bore in mm)	Ideal speed (rpm)	Maximum speed (rpm)	Packaging unit	Article number
Ø 115 x 110 x 19 (an extra 10 mm wide for corner grinding)	1,000-2,000	5,000	2	40018
Ø 115 x 50 x 19	1,000-2,000	5,000	4	40018a



Suitable for

STEEL · STAINLESS STEEL · NON-FERROUS METALS · WOOD

POLY-PTX® Clean Wheel Soft

Ultra-soft nylon fleece cleaning wheel

Cleans and removes pore-deep paint, rust, scale, and dirt on all materials. Effect is similar to that of sand-blasting; cleans without removing material. Ideal for car bodywork, the automotive industry, shipyards, and renovation work by commercial decorators and builders. Can also be used for a coarse satin finish (grit 60).

Tip: Ideal for targeted elimination without rework of scratches from surfaces that have already been satin finished.

Technical data:

Dimensions (Diameter x width x drill bore in mm)	Ideal speed (rpm)	Maximum speed (rpm)	Packaging unit	Article number
Ø 115 x 100 x 19	1,000-2,000	5,000	2	40018w
Ø 115 x 50 x 19	1,000-2,000	5,000	4	40018wa



Professional tip: Ideal for removing scratches and pre-polishing for mirror-finish polishing.



Suitable for

STEEL · WOOD

Wire Wheel

Braided steel brush, corrugated, for greater wire stability

Metal: For removing rust, deburring, rough grinding, and cleaning steel.

Wood: For brushing out soft growth rings on hardwoods and creating coarse, rustic effects.



Technical data:

Dimensions (Diameter x width x drill bore in mm)	Material	Wire thickness (mm)	Maximum speed (rpm)	Packaging unit	Article number
Ø 100 x 25 x 19	Steel	0.27	8,000	4	46302n
Ø 100 x 70 x 19	Steel	0.27	8,000	1	46301



Suitable for

STAINLESS STEEL

Stainless Steel Wire Wheel

Durable stainless steel brush (spring steel)

For cleaning weld seams, deburring (rustproof), removing rust, rough grinding, and removing lacquer, paint, and impurities on such items as perforated stainless steel sheets.



Technical data:

Dimensions (Diameter x width x drill bore in mm)	Material	Wire thickness (mm)	Maximum speed (rpm)	Packaging unit	Article number
Ø 100 x 12 x 19	Stainless steel 1.4310	0.2	8,000	8	46202
Ø 100 x 25 x 19	Stainless steel 1.4310	0.2	8,000	4	46202n
Ø 100 x 70 x 19	Stainless steel 1.4310	0.2	8,000	1	46201



Suitable for

ALL METALS · WOOD

Bristle Wheel

Grit-impregnated, flexible plastic brush



Metal: For rough grinding and deburring.

Wood: For generating rustic effects with soft growth ring transitions in soft wood.

Technical data:

Dimensions (Diameter x width x drill bore in mm)	Material	Maximum speed (rpm)	Bristle thickness (mm)	Packaging unit	Article number
Ø 100 x 12 x 19	Grit-impregnated nylon	8,000	1.27	8	46102
Ø 100 x 25 x 19	Grit-impregnated nylon	8,000	1.27	4	46102n
Ø 100 x 70 x 19	Grit-impregnated nylon	8,000	1.27	1	46101



Suitable for

WOOD

Fibre Wheel

Flexible fibre brush for polishing stained wood surfaces to create a matt sheen effect and for pore-deep dust removal and cleaning.



Technical data:

Dimensions (Diameter x width x drill bore in mm)	Material	Maximum speed (rpm)	Bristle thickness (mm)	Packaging unit	Article number
Ø 100 x 100 x 19	Fibre	8,000	0.4	1	46400



Working with wood:

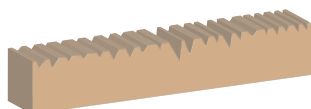

In combination with the wire wheel, the POLY-PTX® is eminently suitable for brushing out soft growth rings in coniferous woods. A coarse rustic effect is easy to produce due to the materials used (wire brush for steel).

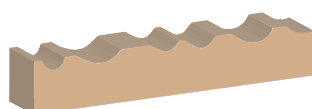

Used with the bristle wheel, a flexible, grit-impregnated plastic brush, the POLY-PTX® is the ideal tool for producing a rustic effect with a soft growth ring transition.

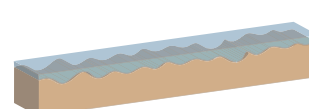

The fibre wheel guarantees stained wood surfaces are polished easily and yet with a top-quality finish. The flexible fibre brush guarantees a perfect matt sheen effect and is ideal for pore-deep cleaning and removal of dust.

Suitable for

POLY-PTX® 802 HT · POLY-PTX® AKKU HT · POLY-PTX® 800

POLY-PTX® Grinding Belt Roller

for belts of up to 30 mm width

Grinding belt roller of **wear-resistant**, soft, fluted **Vulculan plastic** for a better grip and **no-slip work** with lateral stainless steel flanges. With a vibration-damping sleeve for single, double, and quadruple spline shafts, ensuring the wheel runs perfectly.

YOU CAN FIND SUITABLE BELTS ON PAGES 205 AND FOLLOWING.

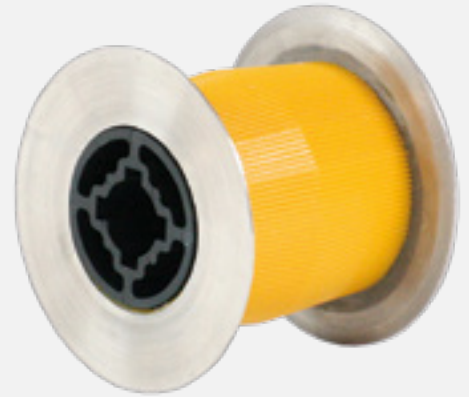

Technical data:

Dimensions (Diameter x width x drill bore in mm)	Material	Maximum speed (rpm)	Packaging unit	Article number
Ø 85 x 70 x 19	Vulculan polyurethane with stainless steel flanges	6,500	1	40006va

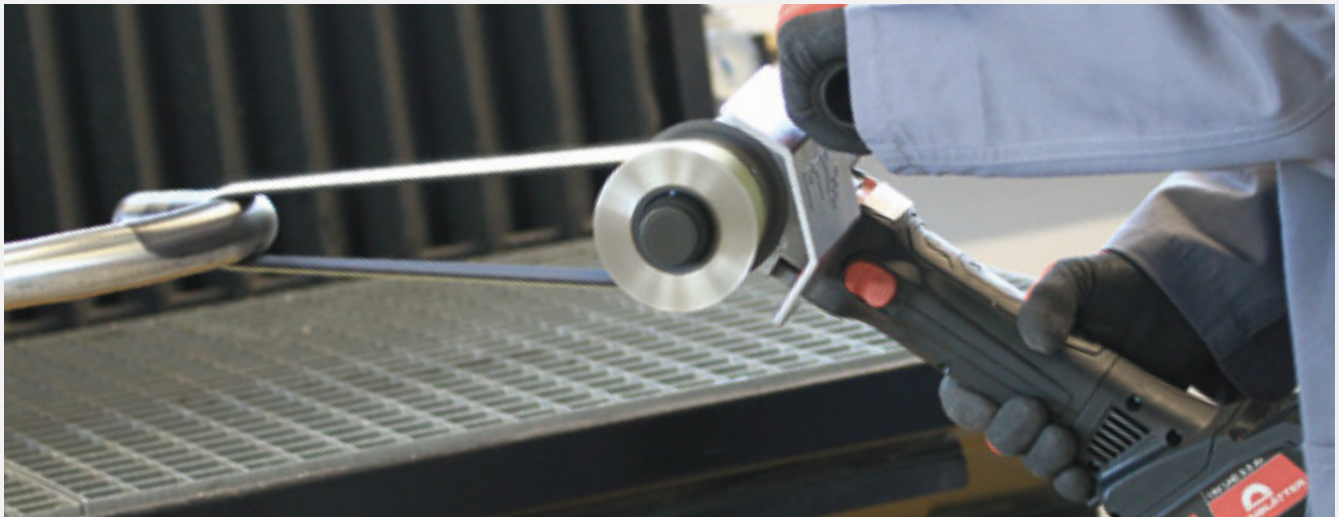

TIP:

Closed grinding belts, such as the grinding belt or Trizact™ belt, are cut open for work on closed pipe constructions, placed across the pipe and taped around in an overlapping pattern (about 370°) along their entire length with our specially developed adhesive tape.



Suitable for

GRINDING BELTS · TRIZACT™ BELTS

POLY-PTX® Special Adhesive Tape



Heat-resistant adhesive tape with linear reinforcement for a tear-resistant hold on grinding belts. For resealing high-quality corundum and Trizact™ belts for work on closed pipe systems with contact wheels.

Technical data:

Width (mm)	Length (m)	Material	Packaging unit	Article number
25	50	High-quality corundum cloth	1	49000

Suitable for

ALL METALS

High-quality Corundum Grinding Belt



Elastically flexed high-quality corundum grinding belt for a variety of grinding work, even on tight radii. For coarse grinding, pre-grinding, smoothing, and removing burrs and rust from round pipes.

ONLY IN CONNECTION WITH A GRINDING BELT ROLLER (POLY-PTX®, PAGE 204, AND VARILEX®, PAGE 138).

Technical data:

Dimensions (mm)	Material	Packaging unit	Grit (K)	Article number
30 x 600	High-quality corundum cloth	10	40	49040
			60	49060
			80	49080
			120	49120
			150	49150
			180	49180
			240	49240

Please Note: Special adhesive tape for resealing (see page 205).



Suitable for

STEEL · STAINLESS STEEL

Trizact™ Belt

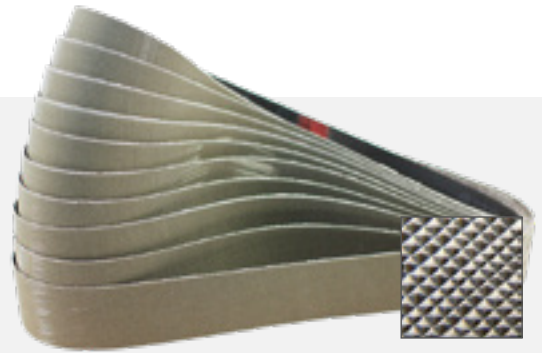

Ideal for removing scratches and pre-polishing for mirror-finish polishing

New type of **abrasive cloth** with **pyramid-shaped grit structure**. **Saves** on several **operating steps** and has high material removal with very **fine results while removing scratches and spot welds**. Ideal pre-polishing for subsequent mirror-finish polishing. Leaves **very minor surface roughness**.

ONLY IN CONNECTION WITH A GRINDING BELT ROLLER (POLY-PTX®, PAGE 204, AND VARILEX®, PAGE 138).

Technical data:

Dimensions (mm)	Packaging unit	Grit (Trizact™)	Grit (K)	Material removal (like approx. K)	Article number
30 x 600	10	A100	220	36	49370
		A65	280	40	49365
		A45	400	50	49345
		A30	600	60	49330
		A16	1200	80	49316
		A06	2000	120	49306

Please Note: Special adhesive tape for resealing (see page 205).



Suitable for

ALL METALS · WOOD · HARD PLASTICS

SC Fleece Belt (T-lock)



Resealable with T-lock

Technical Surface Conditioning fleece belt with the patented T-lock (resealable).

For removing minor scratches and oxide layers, matt finishing, satin finishing, and deburring "closed" pipe constructions and railings.

ONLY IN CONNECTION WITH A GRINDING BELT ROLLER (POLY-PTX®, PAGE 204, AND VARILEX®, PAGE 138).

Technical data:

Dimensions (mm)	Material	Packaging unit	Grit (K)	Colour (fleece)	Grit (fleece)	Article number
30 x 660	SC nylon fleece with reinforcing fabric	5	80	brown	coarse	49001
			180	red	medium	49002
			280	blue	fine	49003
			400	grey	very fine	49007



Suitable for

ALL METALS

BRIGHTEX® Polishing Belts

Berry & Sun



**NEW – NOW AVAILABLE
WITH T-LOCK!**

Polishing material that is already impregnated with **BRIGHTEX® polishing paste** removes the time-consuming hassle of applying pastes and creams to give untreated metal a **shadow-free mirror finish**.

For immediate use without additional pastes and creams!

ONLY IN CONNECTION WITH A GRINDING BELT ROLLER (POLY-PTX®, PAGE 204, AND VARILEX®, PAGE 138).

FEATURES

Step 1: BRIGHTEX® Berry (pre-polishing):

- For applying a rapid high-gloss polish to all metals.
- Pre-polish and main polish in one – save on additional operations.

Step 2: BRIGHTEX® Sun (main polish):

- A mirror finish that's almost like chrome plating – perfect finish.
- For a final high-gloss shine on polished metals.
- For removing any residual clouding and smears from all metals.

• Please Note:

After changing pastes, always remove the polish residue from the workpiece! As necessary, the backing can be rewetted with BRIGHTEX® pastes.

- For freshening up surfaces with a mechanical high-gloss polish.

- Ideal for use with polishing machines and hand-held polishing tools.

- For the best results, use **Eisenblätter care and cleaning products** for removing polish residues (BRIGHTEX® Softclean Powder, Power Cleaner).

- Completely new **high-tech paste formulation** for metals.

NEW: Now available as a re-closable belt with T-lock for working on "closed pipe constructions".

Technical data:

Dimensions (mm)	Version	Variant	Material thickness (mm)	Application	Pkg. unit	Article number
30 x 650	Berry (pink)	Closed	5	High-gloss polishing	4	49005
		T-lock, resealable	5	High-gloss polishing	4	49005t
30 x 650	Sun (yellow)	Closed	5	Mirror-finish polishing	4	49006
		T-lock, resealable	5	Mirror-finish polishing	4	49006t

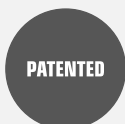

Suitable for

ALL METALS

SuperPolish Belts



Revolutionary special fleece. Used with polishing pastes and creams for a **shiny mirror finish** on stainless steel and non-ferrous metals which leaves **no smears or shadows**.

NEW: Now available as a re-closable belt with T-lock for working on “closed pipe constructions”.

ONLY IN CONNECTION WITH POLISHING PASTES (SEE PAGES 196/198) OR CREMES (PAGE 198).

ONLY IN CONNECTION WITH A GRINDING BELT ROLLER (POLY-PTX®, PAGE 204, AND VARILEX®, PAGE 138).

Please Note: Always use a separate belt for each paste and cream – it is important not to mix different grit sizes.

Technical data:

Dimensions (mm)	Variant	Material thickness (mm)	Material	Pkg. unit	Article number
30 x 650	Closed	5	Polishing fleece	5	49004n
30 x 650	T-lock, resealable	5	Polishing fleece	5	49004t



Suitable for

ALUMINIUM · NON-FERROUS METALS · HARD PLASTICS

Felt Belt (T-lock)



Resealable with T-lock

First-class Merino felt belt with patented **T-lock (re-closable)**, can be used on both sides.

For quick **mirror finishing of “closed” pipe constructions** and railings, from non-ferrous metals to stainless steel.

Suitable for hard plastics as well.

ONLY IN CONNECTION WITH POLISHING PASTES (SEE PAGES 196/198) OR CREMES (PAGE 198).

ONLY IN CONNECTION WITH A GRINDING BELT ROLLER (POLY-PTX®, PAGE 204, AND VARILEX®, PAGE 138).

Please Note: Do not use different pastes or creams on the same felt belt.

Technical data:

Dimensions (mm)	Material thickness (mm)	Material	Packaging unit	Article number
30 x 660	5	Merino felt	5	49004



Pipe grinding made easy!

BELT GRINDING

BELT GRINDING

APPLICATION OVERVIEW 212

SECTION HIGHLIGHTS 213

BELT DIMENSIONS 40 x 780 mm . . 214

POWER TOOLS

NEW PIPE MAX 802 HT 214
NEW PIPE SNIPER 802 HT 218
NEW GLADIUS® 1802 HT 222
NEW GLADIUS® 1802 HT, interchangeable angular
 stop with belt cover 226
NEW Pipe machining accessory set 227

GRINDING AND BLENDING

Zirconium grinding belt 228

FINISHING AND FINE GRINDING

SC fleece belt 229
 Trizact™ belt 230

POLISHING

SuperPolish belts 230
 BRIGHTEX® Berry & Sun polishing belts 231

BELT DIMENSIONS 30 x 533 mm . . 232

POWER TOOLS

NEW PIPE MAX HT MINI 232
NEW PIPE MAX AKKU 236
NEW PIPE MAX AKKU accessories 238
NEW PIPE MAX HT MINI accessory set 239

GRINDING AND BLENDING

NEW Zirconium grinding belt 240

FINISHING AND FINE GRINDING

NEW SC fleece belt 240
NEW Trizact™ belt 241

POLISHING

NEW BRIGHTEX® Berry & Sun polishing belts 242
NEW SuperPolish belt 243

BELT DIMENSIONS 9 x 533 mm . . . 244

POWER TOOLS

NEW BAND-IT flat filing machine 244
NEW BAND-IT AKKU 246
NEW BAND-IT AKKU accessories 248
NEW BAND-IT accessory set 249

GRINDING AND BLENDING

High-quality corundum grinding belt 250

FINISHING AND FINE GRINDING

SC fleece belt 250
 Trizact™ belt 251

POLISHING

Felt belt 251

BRIGHTEX® high-performance polishing pastes . . . 253

BRIGHTEX® Softclean Powder 254

BRIGHTEX® microfibre cloths 254

NEW Power Cleaner 255

Polishing pastes (Classic) 255

Pink polishing cream 255

APPLICATION OVERVIEW

VARILEX® 1000 · VARILEX® POLISHER HT · VARILEX® POLISHER AKKU

Belt dimensions:
30 x 600 mm
30 x 660 mm (T-lock)
Page 136/78/82

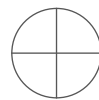

Ø 10-130 mm pipe diameter



POLY-PTX® 802 HT · POLY-PTX® AKKU HT · POLY-PTX® 800

Belt dimensions:
30 x 600 mm
30 x 660 mm (T-lock)
Page 158/162/170



Ø 10-130 mm pipe diameter



PIPE MAX 802 HT

Belt dimensions:
40 x 780 mm
Page 214



Ø 40-130 mm pipe diameter

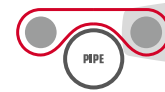

PIPE SNIPER 802 HT

Belt dimensions:
40 x 780 mm
Page 218



Ø 25-70 mm pipe diameter

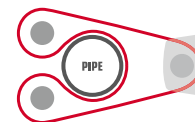

GLADIUS® 1802 HT

Belt dimensions:
40 x 780 mm
Page 222



all sizes flat surfaces



PIPE MAX HT MINI · PIPE MAX AKKU

Belt dimensions:
30 x 533 mm
Page 232/236



Ø 20-80 mm pipe diameter

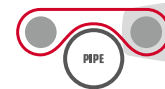

BAND-IT · BAND-IT AKKU

Belt dimensions:
9 x 533 mm
Page 244/246



all sizes flat surfaces



BELT DIMENSIONS 40 x 780 mm

Zirconium grinding belt p. 228

Trizact™ belt p. 230

BRIGHTEX® polishing belts p. 231



SC fleece belt p. 229

SuperPolish belt p. 230

214

BELT DIMENSIONS 30 x 533 mm

Zirconium grinding belt p. 240

Trizact™ belt p. 241

BRIGHTEX® polishing belts p. 242



SC fleece belt p. 240

SuperPolish belt p. 243

232

BELT DIMENSIONS 9 x 533 mm

SC fleece belt p. 250

Felt belt p. 251



High-quality corundum grinding belt p. 250

Trizact™ belt p. 251

244

PIPE MAX 802 HT **NEW**

THE PERFECT FINISH FOR ANY PIPE-GRINDING TASK

MULTI-PURPOSE PIPE GRINDING TOOL WITH GAS PRESSURE DAMPING FOR PERFECT GRINDING AND POLISHING ON CLOSED AND OPEN PIPE CONSTRUCTIONS. FROM SMALL TO LARGE PIPE DIAMETERS.

Effective immediately, the newly developed planetary gear distributes traction across three additional gear wheels in a sophisticated arrangement. This dramatically improves durability and pulling power. Significantly improved airflow technology with turbofan, strongly enclosed rotor and field coil, and the new DUST PREVENT SYSTEM add up to a powerhouse in search of an equal.

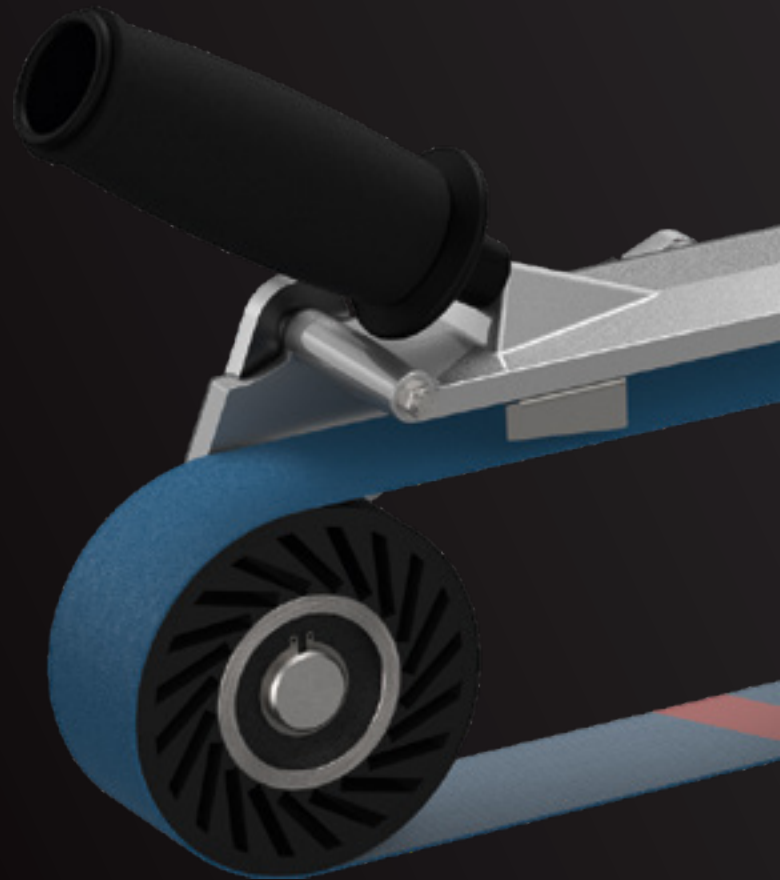

NEW 1,750-WATT MOTOR – EVEN MORE POWER

A refined motor with very high power density and a number of new features ensures completely new standards of torque, productivity, and service life.



POWER TRANSMISSION WITH A PLANETARY GEAR

A high-quality planetary gear has been designed for grinding machines in the low speed range. It ensures wear-resistant power transmission with enormous additional torque.





Compact version (PIPE MAX MINI HT) also available – ideal for pipes Ø 20-80 mm (see page 232).



DUST PREVENT SYSTEM FROM EISENBLÄTTER

The new DUST PREVENT SYSTEM (patent pending) effectively provides protection from coarse swarf and metal particles without impairing the cooling ventilation. A protective cap effectively reduces dust entering the lateral ventilation grilles. Particles bounce off the protective cap. Fresh air intake is only from the air in the rear, which is largely free of particles.



Without DUST PREVENT SYSTEM:

Coarse dust particles are taken into the ventilation grilles without any intervening protection.



With DUST PREVENT SYSTEM:

Coarse dust particles bounce off the protective cap, and air with few particles is taken in from the rear.



Alternative:

For particulate matter (with aluminium, etc.), we recommend, as an alternative to the DUST PREVENT SYSTEM, the particulate matter protection cap (see page 29).

PIPE MAX 802 HT

THE PERFECT FINISH FOR ANY PIPE-GRINDING TASK

OVERVIEW OF PRODUCT ADVANTAGES

- **Extremely powerful, durable motor (1,750 W)** and new HT (high torque) transmission mechanics for wear-resistant power transmission – made entirely in Germany.
- **Planetary gear provides maximum torque throughout the speed range (820 to 3,000 rpm, belt speed 4-14 m/sec)** with a tacho-generator for constant speed, even under load.
- Especially robust and kink-proof cable ensures long service life.
- **Homogeneous, uniform grinding and polishing results for all pipe diameters, large and small.**
- **Patented gas pressure damping concept allows** the grinding and polishing belts to **fit around the pipes to maximum effect with no great effort.**
- **New drive roller** with replaceable rubber O rings guarantees no-slip belts running.
- The contact wheel made from soft polyurethane material ensures **particularly soft contact and permanent elasticity.** It also allows flat surfaces to be ground longitudinally to remove spot welds and eliminate deep scratches, for instance.
- **Quick, simple belt replacement.**
- **No more adjustments required.** Ideal belt guide thanks to the **lateral stainless steel flanges.**
- **Balanced, multi-adjustable handle** allows optimum adjustment to the job in hand.
- Can be set up for **right and left-handed use** or for side and overhead work.
- The **belt unit of gravity die-cast aluminium** is particularly robust and resistant.
- Especially flexible and easy use.

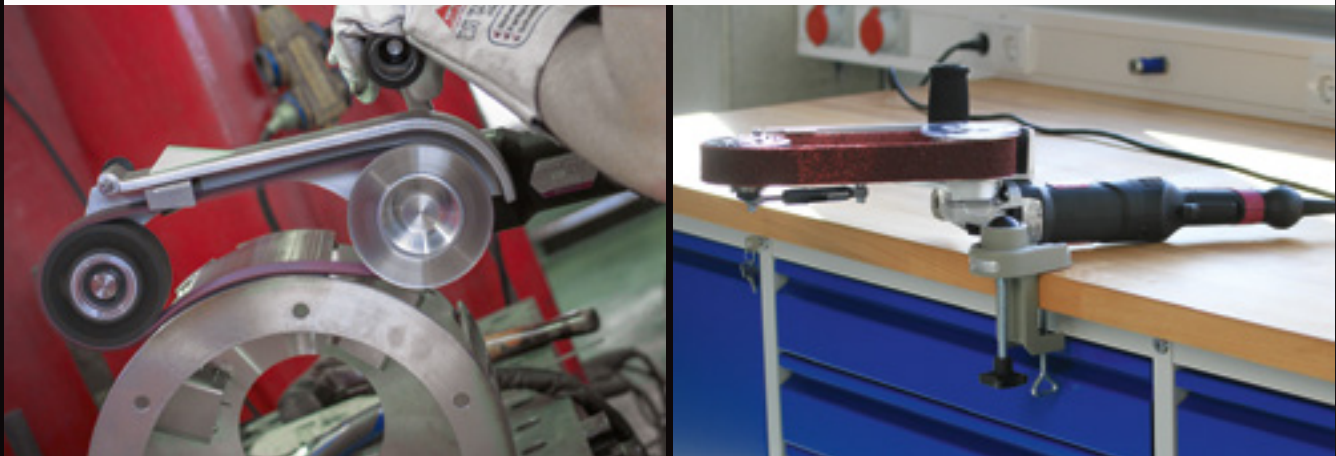

Optional ball joint mount for stationary fixing on workbenches, etc. (see page 289)

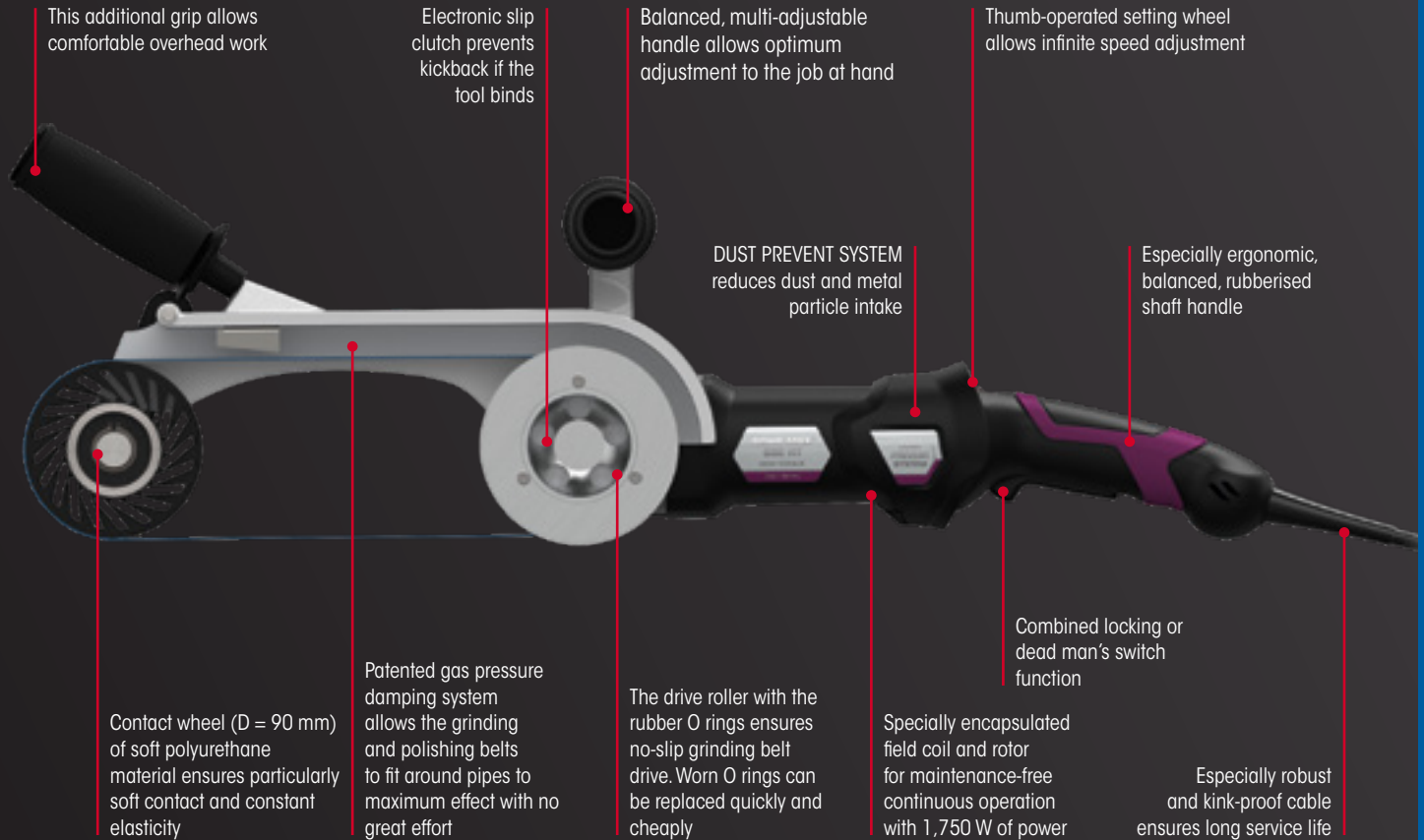

Belt dimensions:
40 x 780 mm

Ø 40-130 mm
pipe diameter

Technical data PIPE MAX 802 HT basic set

Plug type	Cable type	Mains connection (V – Hz)	Power (W)	Belt dimensions (W x L mm)	Speed (rpm)	Belt speed (m/sec)	Weight (kg)	Pkg. unit	Article number
EU (C+F)	Permanent connection	220-240 ~ 50-60	1,750	40 x 780	820-3,000	4.0-13.5	4.7	1	38701
CH (J)	Permanent connection	220-240 ~ 50-60	1,750	40 x 780	820-3,000	4.0-13.5	4.7	1	38701s
US (B)	Permanent connection	110-120 ~ 50-60	1,750	40 x 780	820-3,000	4.0-13.5	4.7	1	38701u
UK (G)	Permanent connection	110-120 ~ 50-60	1,750	40 x 780	820-3,000	4.0-13.5	4.7	1	38701a



- Set contents:**
- 1 PIPE MAX 802 HT machine
 - 1 DUST PREVENT SYSTEM
 - 1 particulate matter protection cap
 - 3 special zirconium belts, 40 x 780 mm
 - 1 special SC fleece belt, 40 x 780 mm
 - 3 replacement rubber O rings

Please Note: We urgently recommend that if you buy this machine, you also order the extremely stable carrying case (see page 285, Art. No. 50104) for the pipe grinder! (Otherwise, the machine will be delivered in a box)

For the practical accessory set, see page 227.

PIPE SNIPER 802 HT **NEW**

360° PIPE MACHINING FROM A SINGLE POSITION

Robust, balanced hand-held machine for quick pipe machining with a high-quality, milled lever system that immediately encloses 2/3 of the diameter of the pipe to be machined! This means that, for the first time, the entire pipe diameter can be ground and polished from a single working position! Very precise, stable mechanism of high-quality milled aluminium.

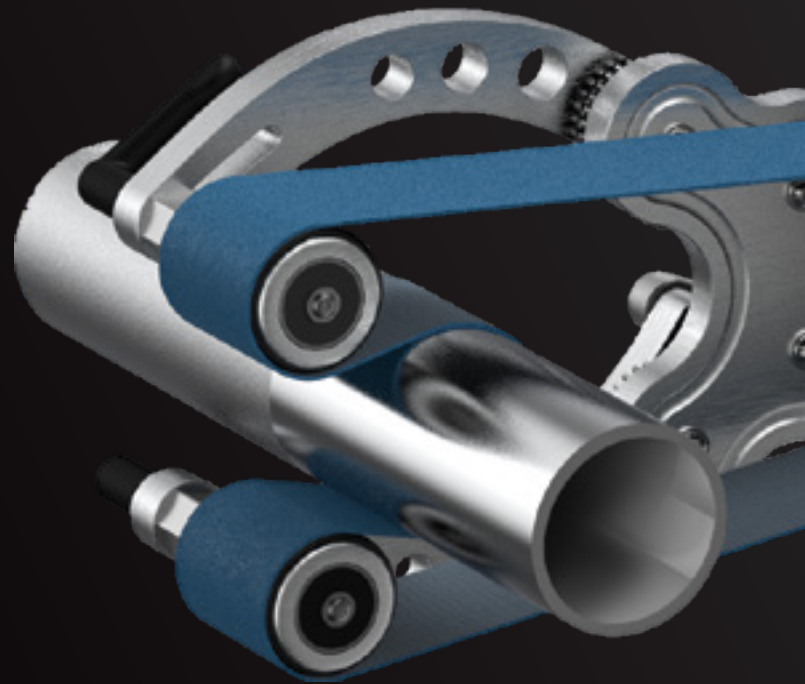

NEW 1,750-WATT MOTOR – EVEN MORE POWER

A refined motor with very high power density and a number of new features ensures completely new standards of torque, productivity, and service life.



POWER TRANSMISSION WITH A PLANETARY GEAR

A high-quality planetary gear has been designed for grinding machines in the low speed range. It ensures wear-resistant power transmission with enormous additional torque.



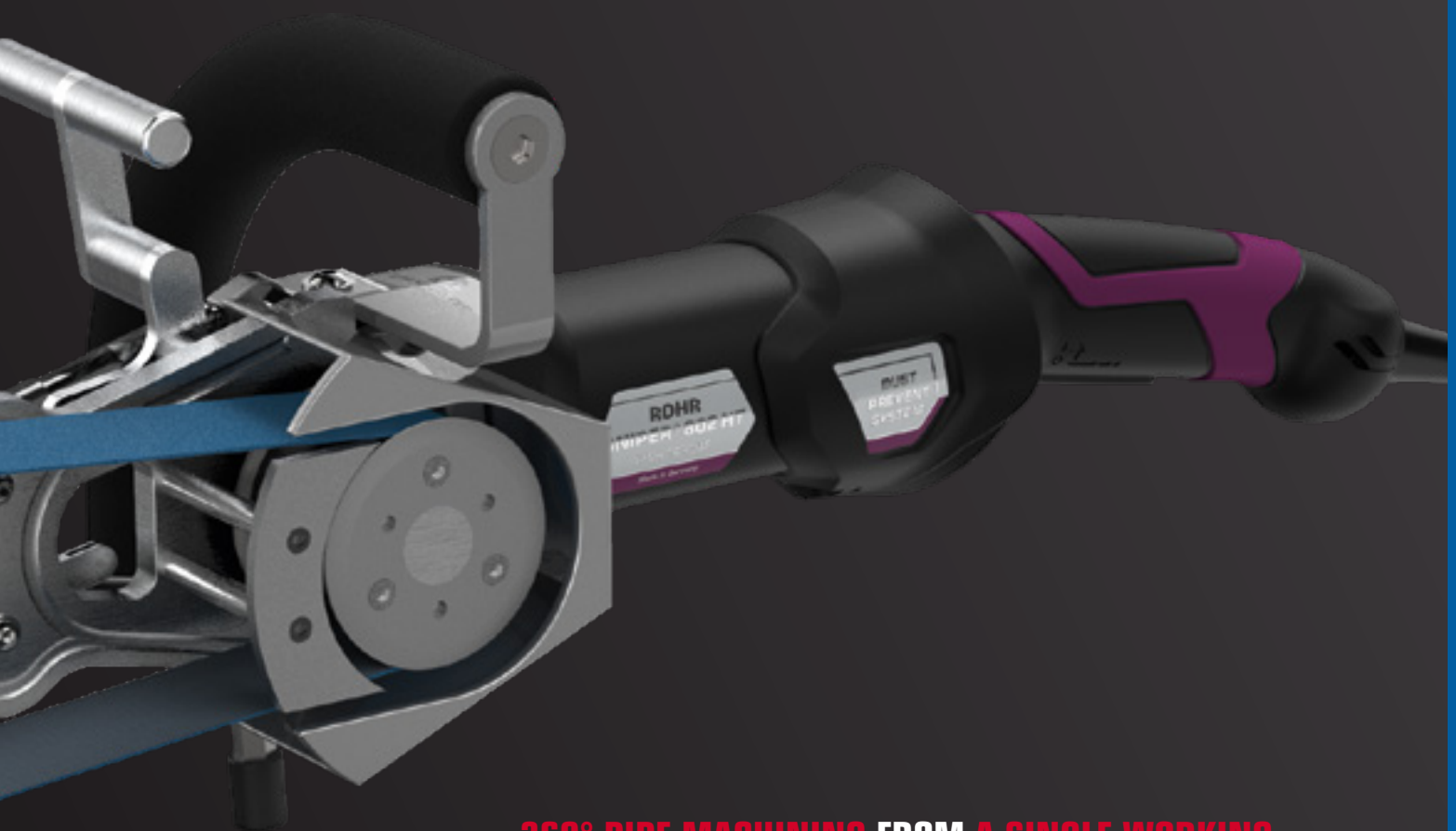

360° PIPE MACHINING FROM A SINGLE WORKING POSITION. REVOLUTION IN PIPE MACHINING RESULTING FROM THE NEW LEVER ENCLOSURE SYSTEM!

DUST PREVENT SYSTEM FROM EISENBLÄTTER

The new DUST PREVENT SYSTEM (patent pending) effectively provides protection from coarse swarf and metal particles without impairing the cooling ventilation. A protective cap effectively reduces dust entering the lateral ventilation grilles. Particles bounce off the protective cap. Fresh air intake is only from the air in the rear, which is largely free of particles.



Without DUST PREVENT SYSTEM:

Coarse dust particles are taken into the ventilation grilles without any intervening protection.



With DUST PREVENT SYSTEM:

Coarse dust particles bounce off the protective cap, and air with few particles is taken in from the rear.



Alternative:

For particulate matter (with aluminium, etc.), we recommend, as an alternative to the DUST PREVENT SYSTEM, the particulate matter protection cap (see page 29).

PIPE SNIPER 802 HT

360° PIPE MACHINING FROM A SINGLE POSITION

OVERVIEW OF PRODUCT ADVANTAGES

- **Minimal force required due to the revolutionary, sophisticated enclosure system.**
- The true 2/3 enclosure (for diameters of 30 to 42 mm) allows machining pipes **through 360 degrees** from a single position. The arms are closed by pulling a lever.
- **Ideal for pipe diameters of 25-70 mm.**
- Innovative technology: **Gas pressure damping system** reduces force required and allows pipe to be **gently enclosed**.
- The balanced shaft handle with non-slip rubber inserts allows the tool to be **operated easily in any conceivable position.**
- **Extremely powerful, durable motor (1,750 W) and new HT (high torque) transmission mechanics** for wear-resistant power transmission – made entirely in Germany.
- **Planetary gear provides maximum torque throughout the speed range (820 to 3,000 rpm, belt speed 3-9 m/sec)** with a tacho-generator for constant speed, even under load.
- New, optimised milled aluminium building components for **reduced weight.**
- **Robust lever mechanism** of high-quality milled materials for professional use and especially long service life (patented).



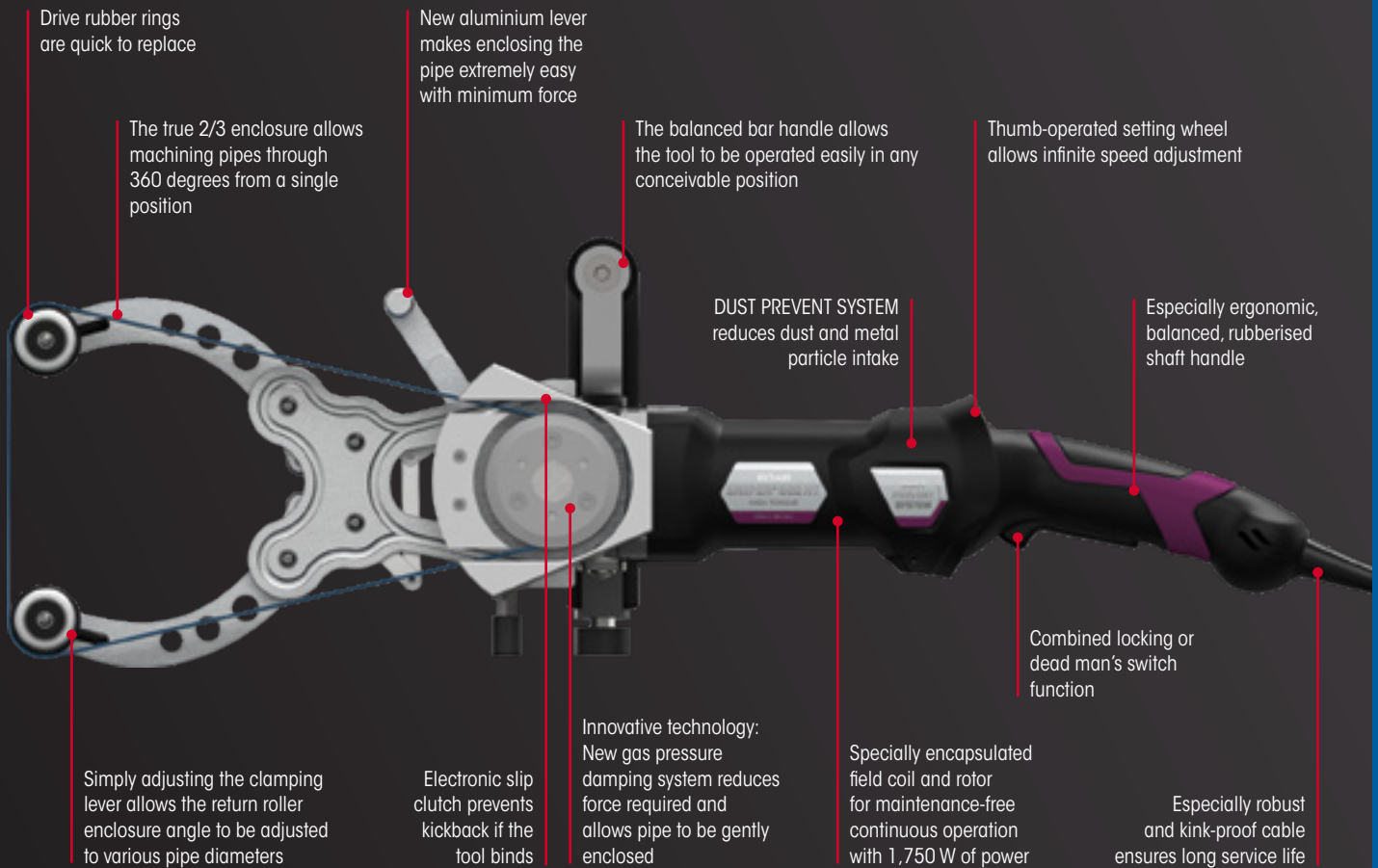

Technical data PIPE SNIPER 802 HT basic set

Plug type	Cable type	Mains connection (V ~ Hz)	Power (W)	Belt dimensions (W x L mm)	Speed (rpm)	Belt speed (m/sec)	Weight (kg)	Pkg. unit	Article number
EU (C+F)	Permanent connection	220-240 ~ 50-60	1,750	40 x 780	820-3,000	2.5-9.2	5.3	1	38801
CH (J)	Permanent connection	220-240 ~ 50-60	1,750	40 x 780	820-3,000	2.5-9.2	5.3	1	38801s
US (B)	Permanent connection	110-120 ~ 50-60	1,750	40 x 780	820-3,000	2.5-9.2	5.3	1	38801u
UK (G)	Permanent connection	110-120 ~ 50-60	1,750	40 x 780	820-3,000	2.5-9.2	5.3	1	38801a



- Set contents:**
- 1 PIPE SNIPER 802 HT machine
 - 1 DUST PREVENT SYSTEM
 - 1 particulate matter protection cap
 - 3 special zirconium belts, 40 x 780 mm
 - 1 special SC fleece belt, 40 x 780 mm
 - 10 replacement drive rubber rings

Please Note: We urgently recommend that if you buy this machine, you also order the extremely stable carrying case (see page 285, Art. No. 50104) for the pipe grinder! (Otherwise, the machine will be delivered in a box)

For the practical accessory set, see page 227.

GLADIUS® 1802 HT **NEW**

THE MULTI-PURPOSE GRINDING SWORD

UNIQUE GRINDING SWORD WITH UNIVERSAL GRINDING PROPERTIES, ATTACHABLE GUIDE SYSTEM FOR GRINDING ANGLES AND RADII PRECISELY. THE NEW OPTIONAL BALL JOINT MOUNT MEANS THAT IT CAN BE USED AS A HAND-HELD MACHINE OR A STATIONARY MACHINE.

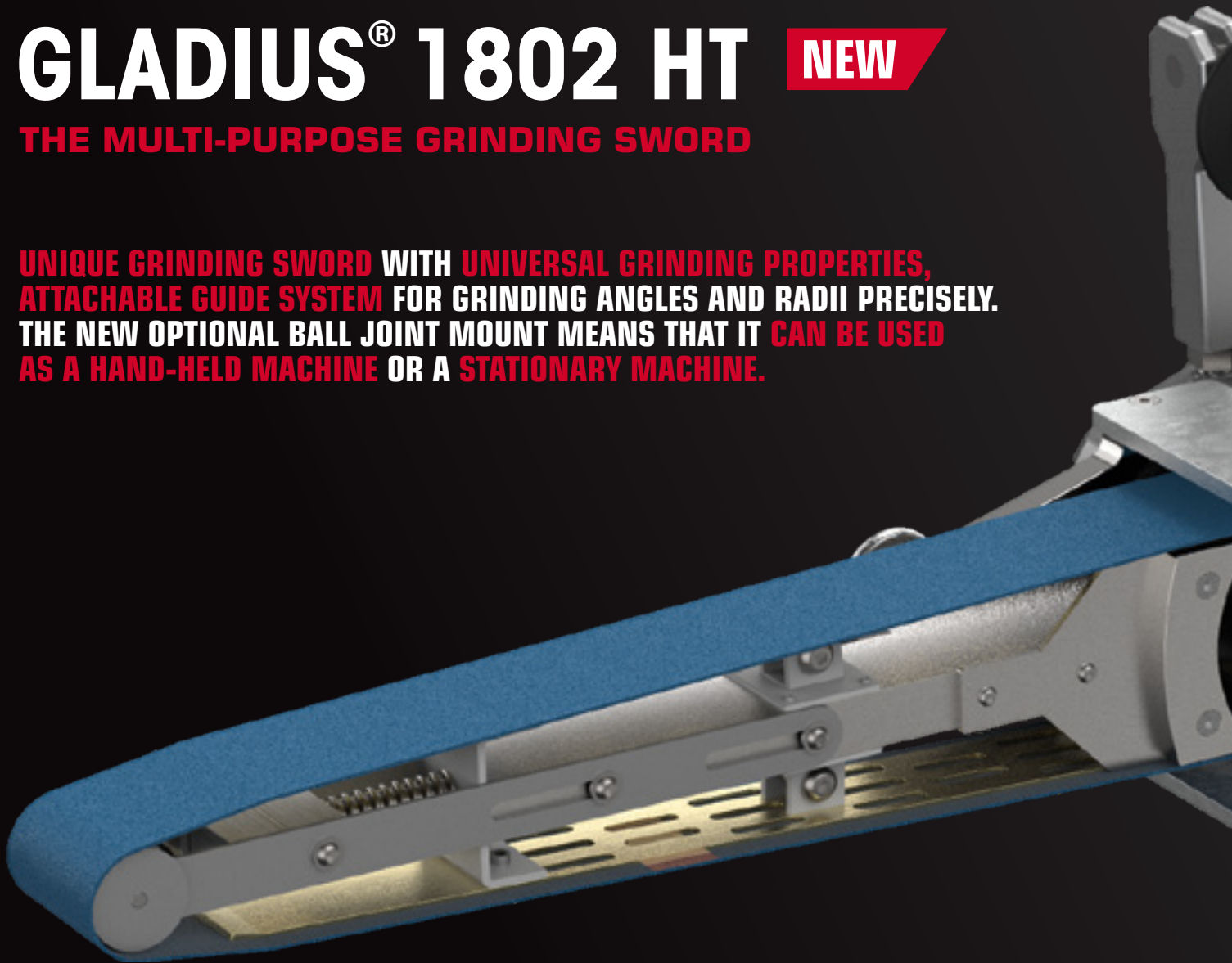

NEW 1,750-WATT MOTOR – EVEN MORE POWER

A refined motor with very high power density and a number of new features ensures completely new standards of torque, productivity, and service life.



POWER TRANSMISSION WITH A PLANETARY GEAR

A high-quality planetary gear has been designed for grinding machines in the low speed range. It ensures wear-resistant power transmission with enormous additional torque.





The optional ball joint mount allows the GLADIUS® 1802 HT function as a stationary belt grinder for blade sharpening, etc.

Precise smoothing and deburring of saw parts



Now you can grind, smooth, deburr, polish, and remove rust and scales quickly with the new, easy-to-use “grinding sword”. Extra-long work area allows machining on one or both sides, even for difficult-to-reach workpieces.

Belt replacement is very simple, meaning that almost any metal, from stainless steel to non-ferrous metals and other materials, from plastic to stone to wood, can be machined quickly.

The GLADIUS® is ideally balanced and can do the work of many common stationary grinding machines without any trouble. Its versatility makes it usable in a workshop or very tight spaces.

GLADIUS® 1802 HT

THE MULTI-PURPOSE GRINDING SWORD

OVERVIEW OF PRODUCT ADVANTAGES

- **For mobile and stationary use:** extremely versatile, can be used for nearly any flat grinding and polishing work with the entire belt arm surface.
- **Optional angle attachment** for grinding work at a fixed angle, replaceable for the belt direction and the opposite direction, for such tasks as sharpening blades and tools.
- Optional table ball joint mount allows stationary use at any angle or position.
- Belt guide extension arm consists of a new, **specially developed alloy for greatly reduced grinding temperatures.**
- Very easy **belt replacement takes only seconds;** the drive roller has low-cost, replaceable rubber rings and lateral stainless steel guides.
- **The drive motor's revolutionary planetary gear makes it durable with great pulling power** at 1,750 watts and 800-3,100 rpm (belt speed: 3-10 m/sec).
- It has a tacho-generator for constant speed, even under load.



Wood grooves



Round bar flat surface

Grind precise flat surfaces and pipe ends

Grinding, smoothing, and deburring in notches, penetrations, etc.

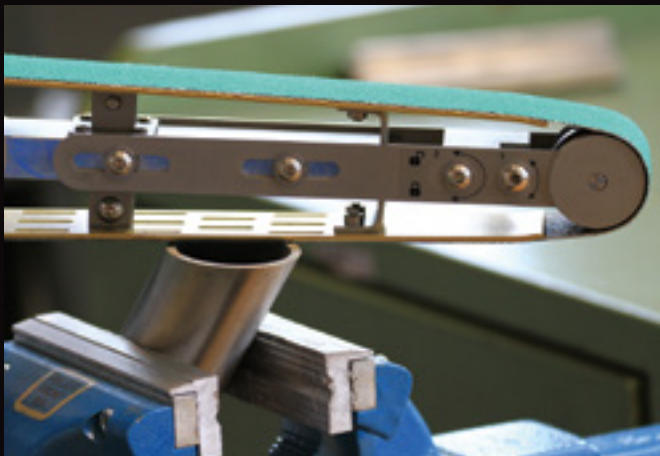

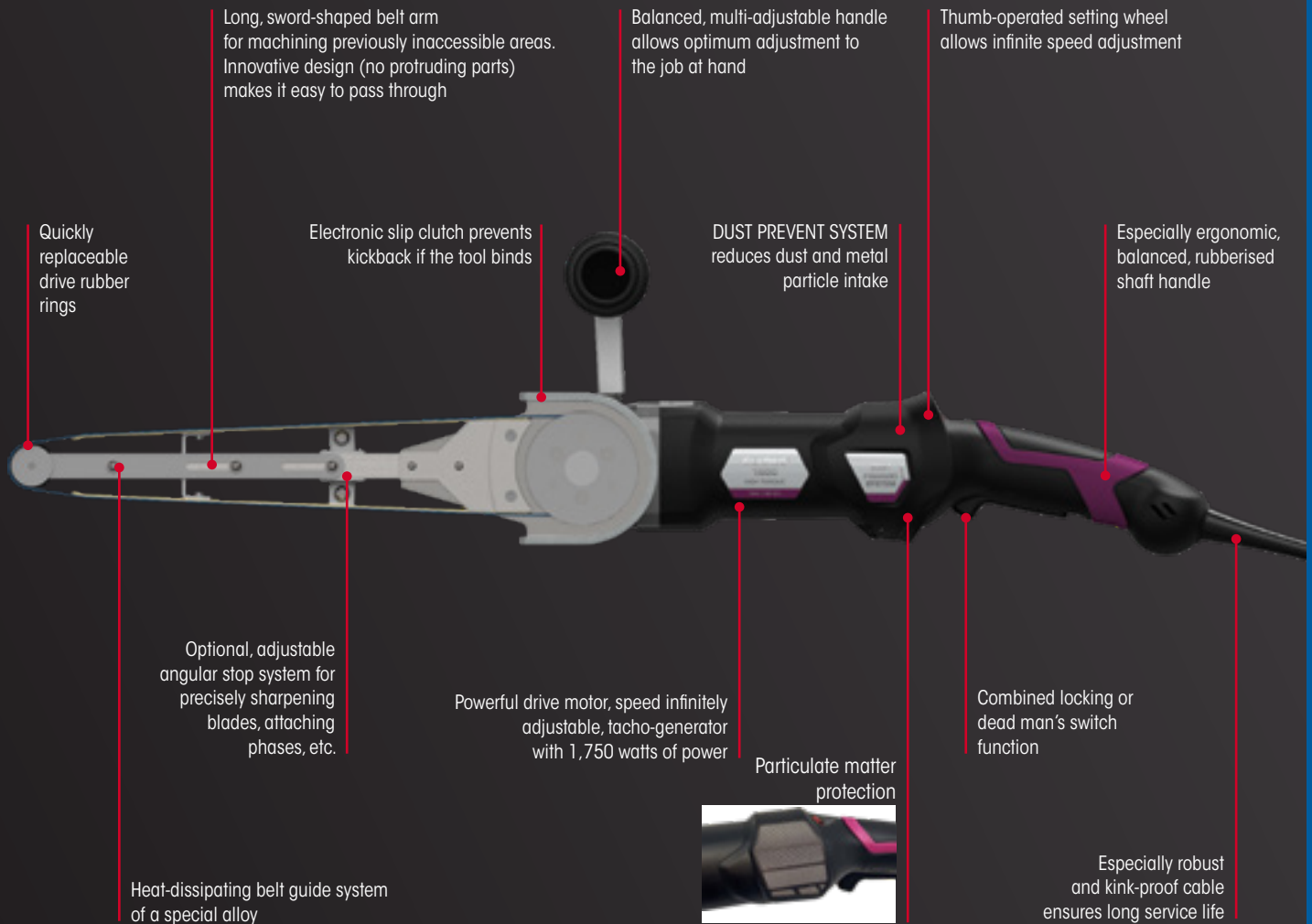

Long, sword-shaped belt arm for machining previously inaccessible areas. Innovative design (no protruding parts) makes it easy to pass through

Balanced, multi-adjustable handle allows optimum adjustment to the job at hand

Thumb-operated setting wheel allows infinite speed adjustment

Quickly replaceable drive rubber rings

Electronic slip clutch prevents kickback if the tool binds

DUST PREVENT SYSTEM reduces dust and metal particle intake

Especially ergonomic, balanced, rubberised shaft handle

Optional, adjustable angular stop system for precisely sharpening blades, attaching phases, etc.

Powerful drive motor, speed infinitely adjustable, tacho-generator with 1,750 watts of power

Combined locking or dead man's switch function

Particulate matter protection



Heat-dissipating belt guide system of a special alloy

Especially robust and kink-proof cable ensures long service life

BELT GRINDING

Technical data GLADIUS® 1802 HT basic set

Plug type	Cable type	Mains connection (V ~ Hz)	Power (W)	Belt dimensions (W x L mm)	Speed (rpm)	Belt speed (m/sec)	Weight (kg)	Pkg. unit	Article number
EU (C+F)	Permanent connection	220-240 ~ 50-60	1,750	40 x 780	800-3,000	2.5-9.2	4.6	1	38901
CH (J)	Permanent connection	220-240 ~ 50-60	1,750	40 x 780	800-3,000	2.5-9.2	4.6	1	38901s
US (B)	Permanent connection	110-120 ~ 50-60	1,750	40 x 780	800-3,000	2.5-9.2	4.6	1	38901u
UK (G)	Permanent connection	110-120 ~ 50-60	1,750	40 x 780	800-3,000	2.5-9.2	4.6	1	38901a



- Set contents:**
- 1 GLADIUS® 1802 HT machine
 - 1 DUST PREVENT SYSTEM
 - 1 particulate matter protection cap
 - 4 special zirconium belts, 40 x 780 mm
 - 3 replacement drive rubber rings

Please Note: We urgently recommend that if you buy this machine, you also order the extremely stable carrying case (see page 285, Art. No. 50104) for the pipe grinder! (Otherwise, the machine will be delivered in a box)

For the practical accessory set, see page 227.

POWER TOOLS

BELT DIMENSIONS 40 x 780 mm

Suitable for

GLADIUS®

NEW

Interchangeable Angular Stop With Belt Cover

For high-precision work such as tool grinding from a wide range of angles and of a wide range of radii, sharpening and polishing of metals of any kind, right up to precise knife grinding

The interchangeable, robust angular stop with belt cover immediately allows precise, stationary work such as sharpening tools (knives, trowels, chocks, and much more). Either belt direction, and a precise angle, can be selected. The optional ball joint table mount transforms the GLADIUS® into a perfect mini-workshop for anyone.

The associated stable belt protection eliminates any risk of injury due to inadvertent contact with moving belts. The selection of a wide variety of grinding and polishing belts allows quick, precise coarse, fine grinding as well as polishing.

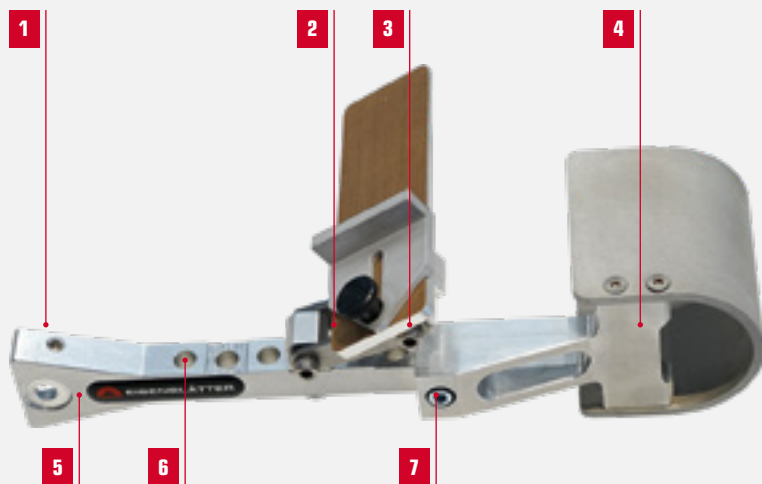

- 1** Mounting bolt for a secure connection
- 2** Laterally adjustable longitudinal angular hand guide (45-90°)
- 3** Infinitely adjustable angular support table (15-90°) (in the belt's running direction and the opposite direction)
- 4** Stable aluminium protective cover with an extension arm
- 5** Sturdy attachment arm milled from solid aluminium with surface protection
- 6** Six positioning holes for flexible placement of the angular support table
- 7** Docking station for connecting the protective cover

Technical data:

Can be used with:	Adjustable angular stop of:	Pkg. unit	Article number
GLADIUS® 1802 HT, GLADIUS® 1800	15-90°	1	38902

Allows high-precision work such as tool grinding from a wide range of angles and of a wide range of radii, sharpening and polishing of metals of any kind, right up to precise knife grinding



Suitable for

PIPE MAX · GLADIUS® · PIPE SNIPER

NEW

Pipe Machining Accessory Set

Belt dimensions 40 x 780 mm



The pipe machining accessory set means that the right tools are always handy. The ideal addition to your machine. Suitable for many tasks ranging from coarse and fine grinding (industrial finish) to perfect mirror finishing – all safely stowed in the stable carrying case.

Technical data:

Function	Can be used with:	Pkg. unit	Article number
Coarse and fine grinding to a mirror finish	PIPE MAX, GLADIUS®, PIPE SNIPER	1	38702

Contents:

- | | | |
|---|---|---|
| <ul style="list-style-type: none"> 1 basic carry case 8 special zirconium belts 6 special SC fleece belts 6 special Trizact™ belts 4 special BRIGHTEX® Berry polishing belts | <ul style="list-style-type: none"> 4 special BRIGHTEX® Sun polishing belts 2 BRIGHTEX® microfibre cloths 1 BRIGHTEX® Softclean Powder 1 BRIGHTEX® Berry mini pre-polishing paste 1 BRIGHTEX® Sun mini post-polishing paste | <ul style="list-style-type: none"> 1 BRILLIANCE CLEAN 50 ml 1 Power Cleaner 50 ml 1 INOX PROTECT 50 ml |
|---|---|---|

THE IDEAL ADDITION FOR THESE EISENBLÄTTER MACHINES:

PIPE MAX 802 HT p. 214

GLADIUS® 1802 HT p. 222

PIPE SNIPER 802 HT p. 218



GRINDING AND BLENDING

BELT DIMENSIONS 40 x 780 mm

Suitable for

STEEL · STAINLESS STEEL

Zirconium Grinding Belt



High-quality, flexible zirconium grinding belt with cooling agents for **removing material from weld seams; eliminating deep scratches, rust, and scale;** and performing coarse industrial finishing work. Prevents discolouration.

Suitable for: PIPE MAX · PIPE SNIPER · GLADIUS®

Technical data:

Dimensions (mm)	Material	Packaging unit	Grit (K)	Article number
40 x 780	Zirconium cloth with highly active cooling agents	10	40	38524
			60	38526
			80	38528
			120	38529



Suitable for

STEEL · STAINLESS STEEL · NON-FERROUS METALS · WOOD · HARD PLASTICS

SC Fleece Belt

Technical surface conditioning fleece belt for grinding, matt finishing, satin finishing, deburring, and **removing minor scratches** and **oxide layers** on **pipe constructions** and railings.

Suitable for: **PIPE MAX · PIPE SNIPER · GLADIUS®**



Technical data:

Dimensions (mm)	Material	Packaging unit	Grit (K)	Colour (fleece)	Grit (fleece)	Article number
40 x 780	SC nylon fleece with reinforcing fabric	4	80	brown	coarse	38531
			180	red	medium	38532
			280	blue	fine	38533
			400	grey	very fine	38534



FINISHING AND FINE GRINDING, POLISHING

BELT DIMENSIONS 40 x 780 mm

Suitable for

STEEL · STAINLESS STEEL

Trizact™ Belt

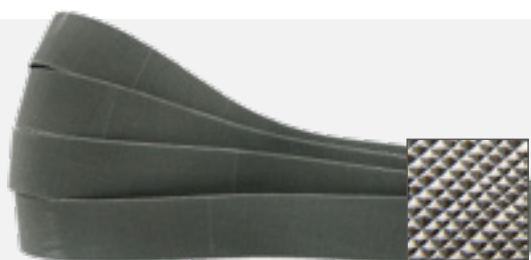

Ideal for removing scratches and pre-polishing for mirror-finish polishing

New type of **abrasive cloth** with **pyramid-shaped grit structure**. **Saves** on several **operating steps** and has high material removal with very **fine results while removing scratches and spot welds**. Ideal pre-polishing for subsequent mirror-finish polishing. Leaves **very minor surface roughness**.

Suitable for: PIPE MAX · PIPE SNIPER · GLADIUS®

Technical data:

Dimensions (mm)	Packaging unit	Grit (Trizact™)	Grit (K)	Material removal (like approx. K)	Article number
40 x 780	10	A100	220	36	38544
		A65	280	40	38545
		A45	400	50	38546
		A30	600	60	38547
		A16	1200	80	38548



Suitable for

ALL METALS

SuperPolish Belt

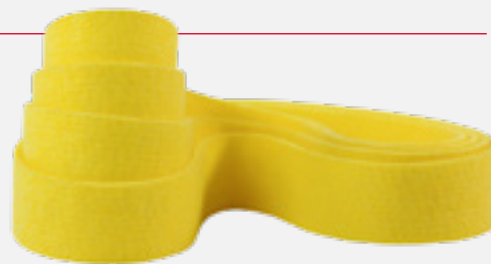

Revolutionary special fleece. Used with polishing pastes and creams for a **shiny mirror finish** on stainless steel and non-ferrous metals which leaves **no smears or shadows**.

ONLY IN CONNECTION WITH POLISHING PASTES (SEE PAGES 253/255) OR CREMES (PAGE 255).

Please Note: Always use a separate SuperPolish belt for each paste and cream – it is important not to mix different grit sizes.

Suitable for: PIPE MAX · PIPE SNIPER · GLADIUS®

Technical data:

Dimensions (mm)	Material thickness (mm)	Material	Packaging unit	Article number
40 x 780	5	Polishing fleece	4	38550



Suitable for

ALL METALS

BRIGHTEX® Polishing Belts



Berry & Sun

Polishing material that is already impregnated with **BRIGHTEX® polishing paste** removes the time-consuming hassle of applying pastes and creams to give untreated metal a **shadow-free mirror finish. For immediate use** without additional pastes and creams!

FEATURES

Step 1: BRIGHTEX® Berry (pre-polishing):

- For applying a rapid high-gloss polish to all metals.
- Pre-polish and main polish in one – save on additional operations.

Step 2: BRIGHTEX® Sun (main polish):

- A mirror finish that's almost like chrome plating – perfect finish.
- For a final high-gloss shine on polished metals.
- For removing any residual clouding and smears from all metals.
- **Please Note:**
After changing pastes, always remove the polish residue from the workpiece! As necessary, the backing can be rewetted with BRIGHTEX® pastes.

- For reconditioning high-gloss surfaces which have been polished mechanically.
- Ideal for use with polishing machines and hand-held polishing tools.
- For the best results, use **Eisenblätter care and cleaning products** for removing polish residues (BRIGHTEX® Softclean Powder, Power Cleaner).
- Completely new **high-tech paste formulation** for metals.

Suitable for: PIPE MAX · PIPE SNIPER · GLADIUS®

Technical data:

Dimensions (mm)	Version	Material thickness (mm)	Application	Packaging unit	Article number
40 x 780	Berry (pink)	5	High-gloss polishing	4	38551
40 x 780	Sun (yellow)	5	Mirror-finish polishing	4	38552



PIPE MAX HT MINI **NEW**

THE PERFECT FINISH FOR ANY PIPE-GRINDING TASK

MULTI-PURPOSE PIPE GRINDING TOOL WITH GAS PRESSURE DAMPING, ESPECIALLY COMPACT FOR PERFECT GRINDING AND POLISHING ON CLOSED AND OPEN PIPE CONSTRUCTIONS. FROM SMALL TO LARGE PIPE DIAMETERS.



PIPE MAX CAN BE DELIVERED AS A BATTERY-POWERED TOOL!

See pages 236–237

NEW 1,750-WATT MOTOR – EVEN MORE POWER

A refined motor with very high power density and a number of new features ensures completely new standards of torque, productivity, and service life.



POWER TRANSMISSION WITH A PLANETARY GEAR

A high-quality planetary gear has been designed for grinding machines in the low speed range. It ensures wear-resistant power transmission with enormous additional torque.





DUST PREVENT SYSTEM FROM EISENBLÄTTER

The new DUST PREVENT SYSTEM (patent pending) effectively provides protection from coarse swarf and metal particles without impairing the cooling ventilation. A protective cap effectively reduces dust entering the lateral ventilation grilles. Particles bounce off the protective cap. Fresh air intake is only from the air in the rear, which is largely free of particles.



Without DUST PREVENT SYSTEM:

Coarse dust particles are taken into the ventilation grilles without any intervening protection.



With DUST PREVENT SYSTEM:

Coarse dust particles bounce off the protective cap, and air with few particles is taken in from the rear.



Alternative:

For particulate matter (with aluminium, etc.), we recommend, as an alternative to the DUST PREVENT SYSTEM, the particulate matter protection cap (see page 29).

PIPE MAX HT MINI

THE PERFECT FINISH FOR ANY PIPE-GRINDING TASK

OVERVIEW OF PRODUCT ADVANTAGES

- The pipe grinding machine, which is **easy to use, manageable, and well-balanced**, has a **new gas pressure damping system**. Delivers clean, **homogeneous grinding results**.
- Automatically adapts to all **round and curved surfaces, pipes, etc.**
- **Belt can be replaced in seconds, extremely versatile**, grinds and polishes **all metals**, depending on belt selection and accessories.
- **Extremely powerful, durable drive motor with 1,750 watts** of power and new type of **planetary gear** for wear-resistant power transmission. The belt unit of **die-cast aluminium** is **particularly robust** and resistant.
- **Planetary gear provides maximum torque throughout the speed range (820 to 3,000 rpm, belt speed 3-9.5 m/sec)** with a tacho-generator for constant speed, even under load.
- Drive roller with a lateral **stainless steel frame** and **replaceable rubber drive rings** for unlimited tool use.
- **Contact wheel** of soft **polyurethane material**, can also be used to remove **weld seams, spot welds, and scratches** during the **linear grinding finish process** (facilitates further satin finishing).
- **Vibration-damping handle** can be adjusted to five positions and used by **right- and left-handers**.
- **100% made in Germany.**



Optional ball joint mount for stationary fixing on workbenches, etc. (see page 289)

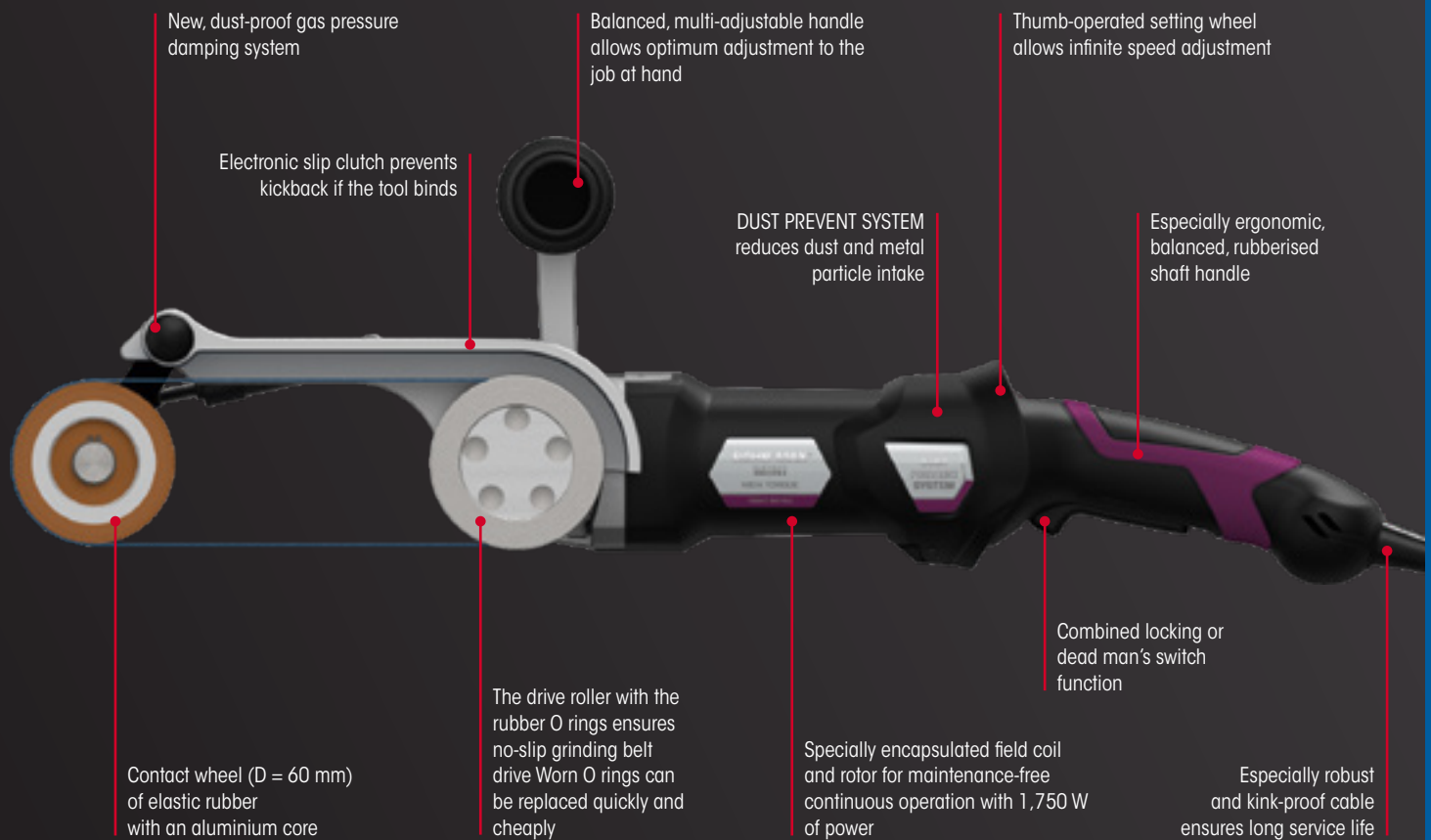

Technical data PIPE MAX HT MINI basic set

Plug type	Cable type	Mains connection (V ~ Hz)	Power (W)	Belt dimensions (W x L mm)	Speed (rpm)	Belt speed (m/sec)	Weight (kg)	Pkg. unit	Article number
EU (C+F)	Permanent connection	220-240 ~ 50-60	1,750	30 x 533	820-3,000	3.0-9.5	3.9	1	38031
CH (J)	Permanent connection	220-240 ~ 50-60	1,750	30 x 533	820-3,000	3.0-9.5	3.9	1	38031s
US (B)	Permanent connection	110-120 ~ 50-60	1,750	30 x 533	820-3,000	3.0-9.5	3.9	1	38031u
UK (G)	Permanent connection	110-120 ~ 50-60	1,750	30 x 533	820-3,000	3.0-9.5	3.9	1	38031a



- Set contents:**
- 1 PIPE MAX HT machine
 - 1 DUST PREVENT SYSTEM
 - 1 particulate matter protection cap
 - 3 special zirconium belts, 30 x 533 mm
 - 3 replacement rubber O rings

Please Note: We urgently recommend that if you buy this machine, you also order the extremely stable carrying case (see page 285, Art. No. 50104) for the pipe grinder! (Otherwise, the machine will be delivered in a box)

For the practical accessory set, see page 239.

PIPE MAX AKKU

NEW

PIPE MACHINING WHILE ON THE GO



THE IDEAL CORDLESS PIPE BELT GRINDER WITH THE POWER OF A PLUG-IN MACHINE. PERFECT FOR CONSTRUCTION SITES, SHIPYARDS (FOR RAILING WORK, FOR EXAMPLE), BALUSTRADE AND HAND-RAIL PRODUCTION, AND MUCH MORE!



OVERVIEW OF PRODUCT ADVANTAGES

- **Homogeneous, uniform grinding and polishing results for all pipe diameters**, large and small.
- **Planetary gear delivers maximum torque.**
- **Patented gas pressure damping concept allows the grinding and polishing belts to fit around the pipes to maximum effect** with no great effort.
- **New drive roller** with replaceable rubber O rings guarantees no-slip belts running.
- **Ideal belt guide thanks to the lateral stainless steel flanges.**
No more adjustments required.
- **Quick, simple belt replacement.**
- **Available for the first time with planetary gear**, giving it the power of a plug-in machine of ~1,600 watts.
- The contact wheel made from soft polyurethane material ensures **particularly soft contact and permanent elasticity**. It also allows flat surfaces to be ground longitudinally to remove spot welds and eliminate deep scratches, for instance.
- **Balanced, multi-adjustable handle** allows optimum adjustment to the job in hand.
- Can be set up for **right and left-handed use** or for side and overhead work.
- The **belt unit of gravity die-cast aluminium** is particularly robust and resistant.



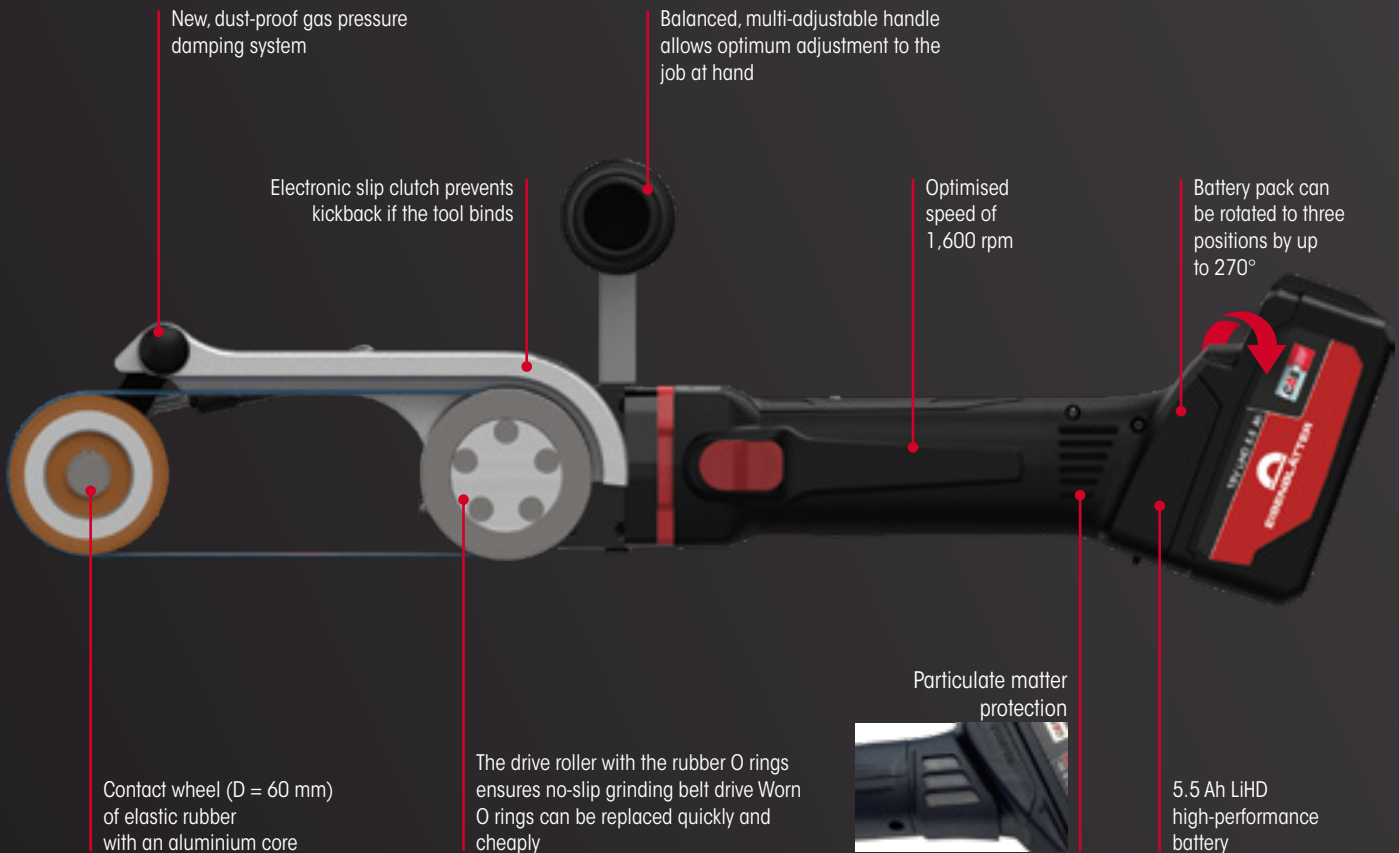

Tip: Especially well-suited for use in hotel facility preparation teams or shipbuilding (railings, etc.)

BELT GRINDING

Technical data PIPE MAX AKKU basic set

Plug type	Cable type	Mains connection (V ~ Hz)	Power (V)	Belt dimensions (mm)	Speed (rpm)	Belt speed (m/sec)	Weight (kg)	Pkg. unit	Article number
EU (C+F)	Permanent connection	220-240 ~ 50-60	18	30 x 533	1,600	5.3	3.24	1	38041



- Set contents:**
- 1 PIPE MAX AKKU machine
 - 1 robust, impact-resistant plastic case for machine and accessories
 - 1 particulate matter protection battery
 - 2 LiHD batteries (5.5 Ah)
 - 1 high-speed charging device including cable
 - 3 special zirconium belts, 30 x 533 mm
 - 3 replacement rubber O rings

Please Note: For the practical accessory set, see page 239.

POWER TOOLS

CORDLESS ALLIANCE SYSTEM

Suitable for

ALL CORDLESS ALLIANCE BATTERIES



High-speed Charging Device

NEW



For quick charging of all sliding-fit Li-ion and LiHD battery packs from 14.4 to 36 volts.

FEATURES

- **Patented "AIR COOLED" charging technology:** Batteries are cooled during charging for a much shorter charging time.
- High charging current ensures that the **battery packs are charged quickly.**
- Very **low stand-by power consumption.**
- Maximum charging current: 6.5 A.
- **Process-controlled charge management** for gentle charging and the greatest possible number of charging cycles.
- One charger for charging all battery packs from our CAS partner: www.cordless-alliance-system.de

Technical data:

Plug type	Cable type	Mains connection (V ~ Hz)	Maximum charging current (A)	Pkg. unit	Article number
EU (C+F)	Permanent connection	220-240 ~ 50-60	6.5	1	50474

Suitable for

ALL CORDLESS ALLIANCE SYSTEM DEVICES



5.5/8.0 Ah Battery

NEW



18 volts, LiHD technology

Powerful high-tech 18-volt battery (LiHD) for all battery-powered tools in the CAS group.

Technical data:

Article	Power (V)	Battery capacity (Ah)	Suitable for	Weight (kg)	Pkg. unit	Article number
5.5 Ah CAS battery	18	5.5	CAS devices	0.89	1	50463
8.0 Ah CAS battery	18	8.0	CAS devices	0.98	1	50473

Suitable for

PIPE MAX HT MINI · PIPE MAX AKKU

NEW

PIPE MAX HT MINI Accessory Set

Belt dimensions 30 x 533 mm



The pipe machining accessory set means that the right tools are always handy. The ideal addition to your machine. Suitable for many tasks ranging from coarse and fine grinding (industrial finish) to perfect mirror finishing – all safely stowed in the stable carrying case.

Technical data:

Function	Can be used with:	Pkg. unit	Article number
Coarse and fine grinding to a mirror finish	PIPE MAX HT MINI, PIPE MAX AKKU	1	38032

Contents:

- | | | |
|---|--|--------------------------|
| 1 basic carry case | 4 special BRIGHTEX® Sun polishing belts | 1 BRILLIANCE CLEAN 50 ml |
| 8 special grinding belts | 2 BRIGHTEX® microfibre cloths | 1 Power Cleaner 50 ml |
| 6 special SC fleece belts | 1 BRIGHTEX® Softclean Powder | 1 INOX PROTECT 50 ml |
| 6 special Trizact™ belts | 1 BRIGHTEX® Berry mini pre-polishing paste | |
| 4 special BRIGHTEX® Berry polishing belts | 1 BRIGHTEX® Sun mini post-polishing paste | |

THE IDEAL ADDITION FOR THESE EISENBLÄTTER MACHINES:

PIPE MAX HT MINI p. 232

PIPE MAX AKKU p. 236



GRINDING AND BLENDING/FINISHING AND FINE GRINDING

BELT DIMENSIONS 30 x 533 mm

Suitable for

STEEL · STAINLESS STEEL

Zirconium Grinding Belt

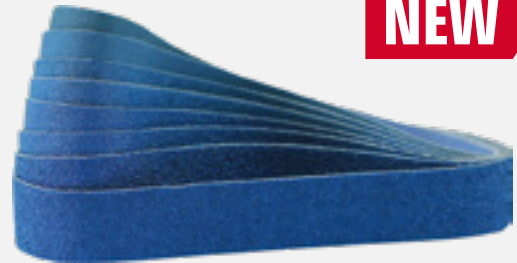

High-quality zirconium grinding belt for **removing material from weld seams; eliminating deep scratches, rust, and scale;** and performing coarse industrial finishing work. Prevents discolouration.

Technical data:

Dimensions (mm)	Material	Packaging unit	Grit (K)	Article number
30 x 533	Zirconium cloth with highly active cooling agents	10	40	38074
			60	38076
			80	38078
			120	38079



Suitable for

STEEL · STAINLESS STEEL · NON-FERROUS METALS · WOOD · HARD PLASTICS

SC Fleece Belt

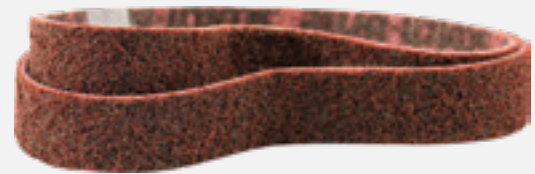

Technical surface conditioning fleece belt for grinding, matt finishing, satin finishing, deburring, and **removing minor scratches** and **oxide layers** on **pipe constructions** and railings.

Technical data:

Dimensions (mm)	Material	Packaging unit	Grit (K)	Colour (fleece)	Grit (fleece)	Article number
30 x 533	SC nylon fleece with reinforcing fabric	4	80	brown	coarse	38081
			180	red	medium	38082
			280	blue	fine	38083



Suitable for

STEEL · STAINLESS STEEL

Trizact™ Belt



Ideal for removing scratches and pre-polishing for mirror-finish polishing

New type of **abrasive cloth** with **pyramid-shaped grit structure**. **Saves** on several **operating steps** and has high material removal with very **fine results while removing scratches and spot welds**.

Ideal pre-polishing for subsequent mirror-finish polishing. Leaves **very minor surface roughness**.

Technical data:

Dimensions (mm)	Packaging unit	Grit (Trizact™)	Grit (K)	Material removal (like approx. K)	Article number
30 x 533	10	A100	220	36	38085
		A65	280	40	38086
		A45	400	50	38087
		A30	600	60	38088
		A16	1200	80	38089



POLISHING

BELT DIMENSIONS 30 x 533 mm

Suitable for

ALL METALS

NEW

BRIGHTEX[®] Polishing Belts



Berry & Sun

Polishing material that is already impregnated with **BRIGHTEX[®] polishing paste** removes the time-consuming hassle of applying pastes and creams to give untreated metal a **shadow-free mirror finish**.

For immediate use without additional pastes and creams!

FEATURES

Step 1: BRIGHTEX[®] Berry (pre-polishing):

- For applying a rapid high-gloss polish to all metals.
- Pre-polish and main polish in one – save on additional operations.

Step 2: BRIGHTEX[®] Sun (main polish):

- A mirror finish that's almost like chrome plating – perfect finish.
- For a final high-gloss shine on polished metals.
- For removing any residual clouding and smears from all metals.
- **Please Note:**
After changing pastes, always remove the polish residue from the workpiece! As necessary, the backing can be rewetted with BRIGHTEX[®] pastes.

- For reconditioning high-gloss surfaces which have been polished mechanically.
- Ideal for use with Eisenblätter pipe belt grinding machines.
- For the best results, use **Eisenblätter care and cleaning products** for removing polish residues (BRIGHTEX[®] Softclean Powder, Power Cleaner).
- Completely new **high-tech paste formulation** for metals.

Technical data:

Dimensions (mm)	Version	Material thickness (mm)	Application	Packaging unit	Article number
30 x 533	Berry (pink)	5	High-gloss polishing	4	38091
30 x 533	Sun (yellow)	5	Mirror-finish polishing	4	38092



Suitable for

ALL METALS

NEW

SuperPolish Belt



Revolutionary special fleece. Used with polishing pastes and creams for a **shiny mirror finish** on stainless steel and non-ferrous metals which leaves **no smears or shadows**.

ONLY IN CONNECTION WITH POLISHING PASTES (SEE PAGES 253/255) OR CREMES (PAGE 255).

Please Note: Always use a separate SuperPolish belt for each paste and cream – it is important not to mix different grit sizes.

Technical data:

Dimensions (mm)	Material thickness (mm)	Material	Packaging unit	Article number
30 x 533	5	Polishing fleece	4	38090



BAND-IT **NEW**

**FINE MACHINING
WITH PRECISION**



**BAND-IT CAN BE DELIVERED
AS A BATTERY-POWERED TOOL!**

See pages 246-247

EISENBLÄTTER introduces the newly developed, especially compact, powerful, high-quality flat filing machine equipped with a new damping system. A dust-protected, enclosed gas pressure damping system ensures quick belt tension and especially easy belt replacement.

OVERVIEW OF PRODUCT ADVANTAGES

- The **slim, compact design** is ideal for **work even in tight spots** – edges, grooves, corners, etc. Especially interesting for work in building **railings, equipment, and tools and in metal construction generally**.
- For **grinding and polishing belts** between **5 and 9 mm** width. Belt replacement in seconds. Quick-change **brass contact wheel** with high-quality needle bearings, and rubberised running surfaces.
- **Grinding and polishing belts** are **automatically** guided and **adjusted**. A knurled screw allows pretension to be locked firmly for greater contact pressure and extremely precise work.
- Balanced, powerful machine, **900 watts**, variable-speed, **1,900-7,900 rpm**. **Dust-proof gas pressure damping system** provides elasticity. For mobile or **stationary use** e.g. with a ball joint table mount.
- **100% made in Germany.**



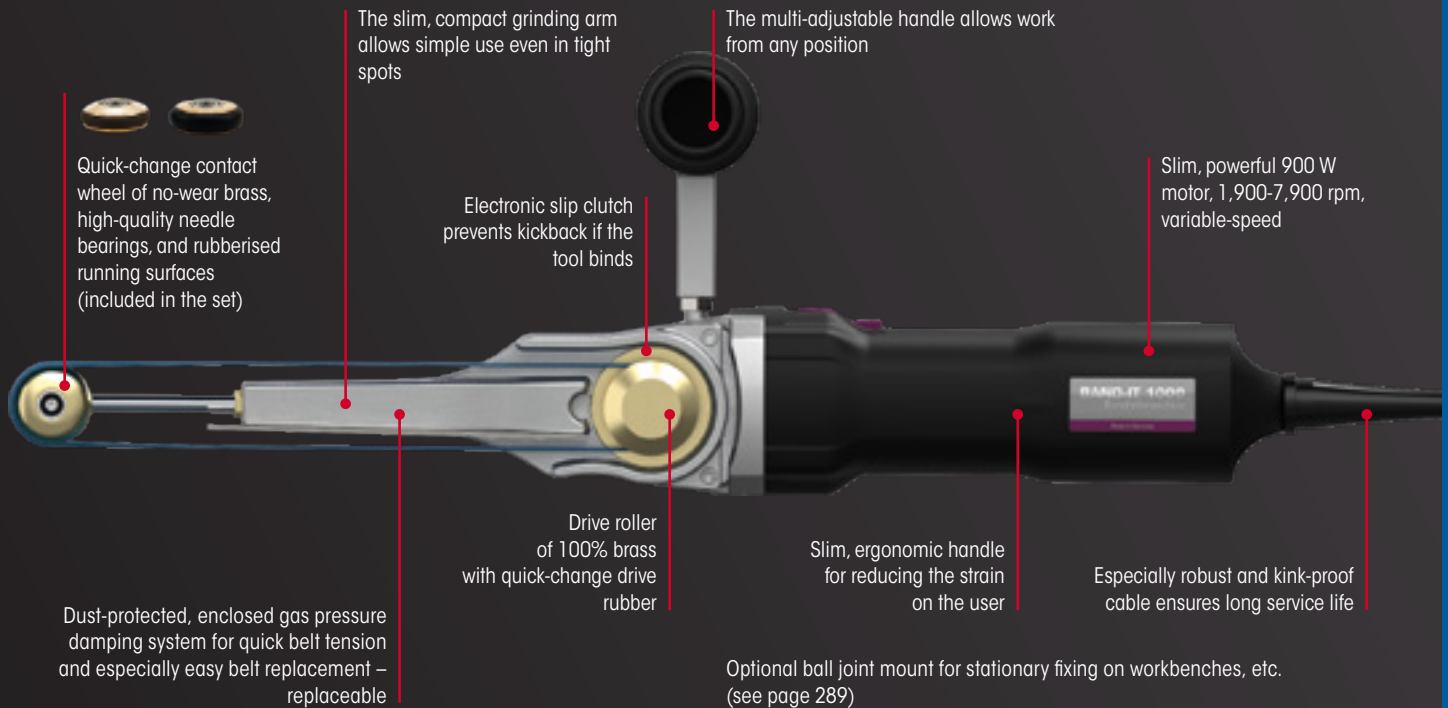

Optional ball joint mount for stationary fixing on workbenches, etc. (see page 289)



Belt dimensions:
3/5/9 x 533 mm

all sizes flat surfaces

Technical data Band-It basic set

Plug type	Cable type	Mains connection (V ~ Hz)	Power (W)	Belt dimensions (mm)	Speed (rpm)	Belt speed (m/sec)	Weight (kg)	Pkg. unit	Article number
EU (C+F)	Permanent connection	220-240 ~ 50-60	900	5/9 x 533	1,900-7,900	3-12	3.9	1	38061



- Set contents:**
- 1 Band-It machine
 - 1 robust, impact-resistant plastic case for the machine and accessories
 - 1 interchangeable roller for 9 x 533 mm fleece and polishing belts
 - 8 grinding belts 9 x 533 mm
 - 1 interchangeable roller for 5 x 533 mm grinding belts

Please Note: For the practical accessory set, see page 249.

BAND-IT AKKU **NEW**

FINE MACHINING WITH CORDLESS FREEDOM



OVERVIEW OF PRODUCT ADVANTAGES

- The **slim, compact design** is ideal for work even in **tight spots** – edges, grooves, corners, etc. Especially interesting for work in building **railings, equipment, and tools** and in **metal construction generally**.
- For **grinding and polishing belts** between **5 and 9 mm width**. Belt replacement in seconds. Quick-change **brass contact wheel** with high-quality needle bearings, and rubberised running surfaces.
- **Grinding and polishing belts** are **automatically** guided and **adjusted**. A knurled screw allows pretension to be locked firmly for greater contact pressure and extremely precise work.
- **High-performance battery-powered motor with 18-volt LiHD technology**, as powerful as plug-in devices, **5.5 Ah of battery power (two batteries** in the basic set). **Option** of adding **8.0 Ah** batteries or a **high-speed charger**.
- **Dust-proof gas pressure damping system** provides elasticity. For mobile or **stationary use** e.g. with a **ball joint table mount**.
- **100% made in Germany.**



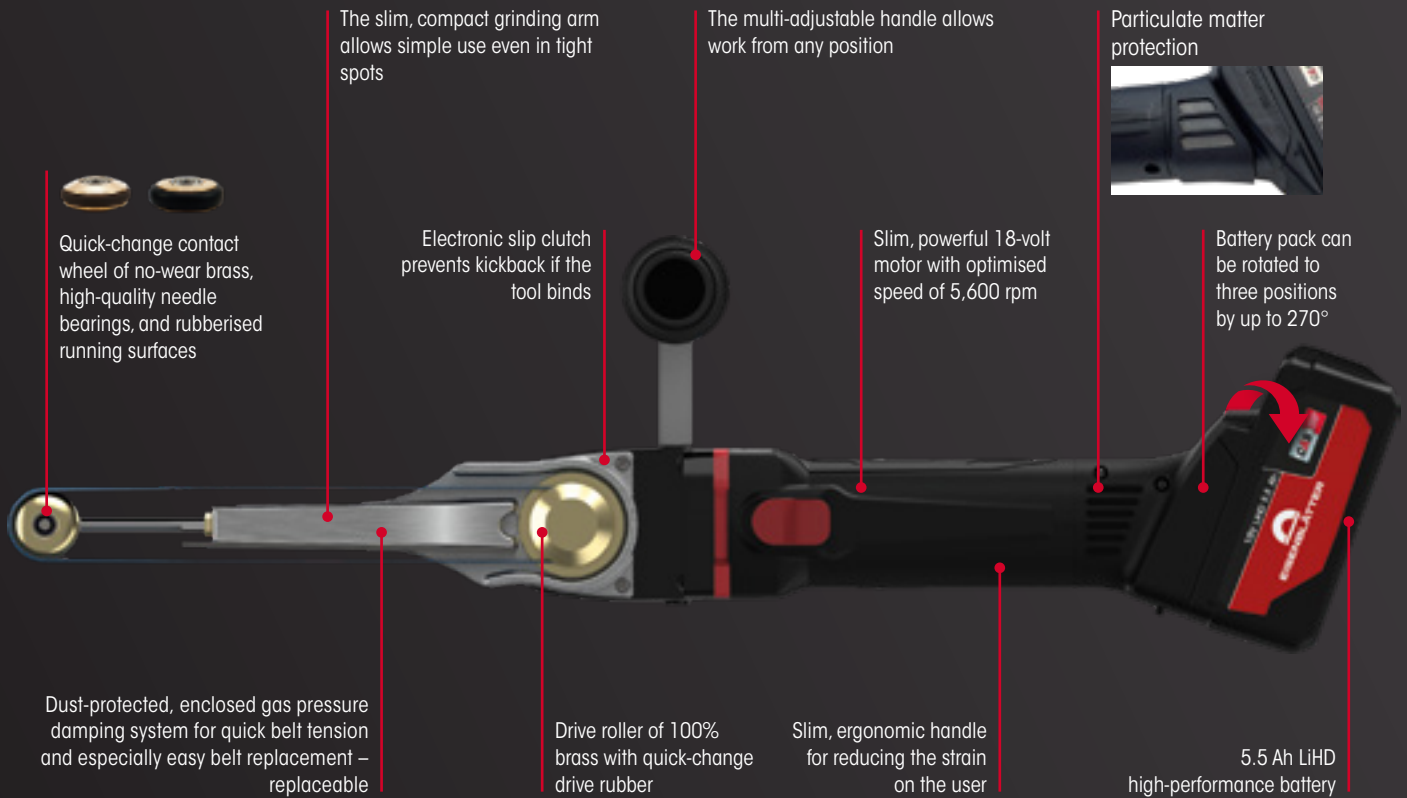

EISENBLÄTTER introduces the newly developed, especially compact, powerful, high-quality flat filing machine equipped with a new damping system – with all the properties and power of plug-in machines. The sturdy LiHD-battery-powered motor makes it possible.

Technical data BAND-IT AKKU basic set

Plug type	Cable type	Mains connection (V ~ Hz)	Power (V)	Belt dimensions (mm)	Belt speed (m/sec)	Speed (rpm)	Weight (kg)	Pkg. unit	Article number
EU (C+F)	Permanent connection	220-240 ~ 50-60	18	5/9 x 533	8.75	5,600	2.2	1	38101



- Set contents:**
- 1 BAND-IT AKKU machine
 - 1 robust, impact-resistant plastic case for machine and accessories
 - 1 particulate matter protection battery
 - 2 LiHD batteries (5.5 Ah)
 - 1 high-speed charging device including cable
 - 1 interchangeable roller for 9 x 533 mm fleece and polishing belts
 - 1 interchangeable roller for 5 x 533 mm grinding belts
 - 8 grinding belts 9 x 533 mm

Please Note: For the practical accessory set, see page 249.

Suitable for

ALL CORDLESS ALLIANCE BATTERIES



High-speed Charging Device

NEW



For quick charging of all sliding-fit Li-ion and LiHD battery packs from 14.4 to 36 volts.

FEATURES

- **Patented "AIR COOLED" charging technology:** Batteries are cooled during charging for a much shorter charging time.
- High charging current ensures that the **battery packs are charged quickly.**
- Very **low stand-by power consumption.**
- Maximum charging current: 6.5 A.
- **Process-controlled charge management** for gentle charging and the greatest possible number of charging cycles.
- One charger for charging all battery packs from our CAS partner: www.cordless-alliance-system.de

Technical data:

Plug type	Cable type	Mains connection (V ~ Hz)	Maximum charging current (A)	Pkg. unit	Article number
EU (C+F)	Permanent connection	220-240 ~ 50-60	6.5	1	50474

Suitable for

ALL CORDLESS ALLIANCE SYSTEM DEVICES



5.5/8.0 Ah Battery

NEW



18 volts, LiHD technology

Powerful high-tech 18-volt battery (LiHD) for all battery-powered tools in the CAS group.

Technical data:

Article	Power (V)	Battery capacity (Ah)	Suitable for	Weight (kg)	Pkg. unit	Article number
5.5 Ah CAS battery	18	5.5	CAS devices	0.89	1	50463
8.0 Ah CAS battery	18	8.0	CAS devices	0.98	1	50473

Suitable for

BAND-IT · BAND-IT AKKU

NEW

BAND-IT Accessory Set



The ideal addition to your BAND-IT belt filer

The Band-It accessory set accessory set means that the right tools are always handy. The ideal addition to your machine. Suitable for many tasks ranging from coarse and fine grinding (industrial finish) to perfect mirror finishing – all safely stowed in the stable carrying case.

Technical data:

Function	Can be used with:	Pkg. unit	Article number
Coarse and fine grinding to a mirror finish	BAND-IT, BAND-IT AKKU	1	38062

Contents:

- 1 mobile tool case
- 40 narrow high-quality corundum belts (9 x 533 mm)
- 20 narrow high-quality corundum belts (5 x 533 mm)
- 6 narrow SC fleece belts (9 x 533 mm)
- 6 narrow Trizact™ belts (9 x 533 mm)
- 6 narrow felt belts (9 x 533 mm)
- 2 BRIGHTEX® microfibre cloths
- 1 BRIGHTEX® Softclean Powder
- 1 BRIGHTEX® Berry mini pre-polishing paste
- 1 BRIGHTEX® Sun mini post-polishing paste
- 1 BRILLIANCE CLEAN 50 ml
- 1 Power Cleaner 50 ml
- 1 INOX PROTECT 50 ml

THE IDEAL ADDITION FOR THESE EISENBLÄTTER MACHINES:

BAND-IT p. 244

BAND-IT AKKU p. 246



GRINDING AND BLENDING/FINISHING AND FINE GRINDING

BELT DIMENSIONS 9 x 533 mm

Suitable for

ALL METALS

High-quality Corundum Grinding Belt



Elastically flexed high-quality corundum grinding belt for a variety of grinding work, such as coarse grinding, pre-grinding, smoothing, and removal of scale and rust, even on tight radii.

Technical data:

Dimensions (mm)	Material	Packaging unit	Grit (K)	Article number
9 x 533	High-quality corundum cloth	10	40	49024
			60	49026
			80	49028
			120	49029
5 x 533	High-quality corundum cloth	10	40	49504
			60	49506
			80	49508
			120	49509



Suitable for

ALL METALS · WOOD · HARD PLASTICS

SC Fleece Belt

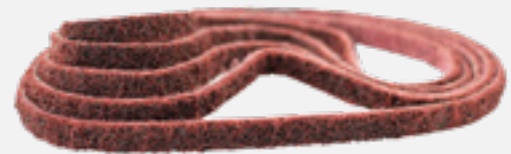

Technical surface conditioning fleece belt for grinding, matt finishing, satin finishing, deburring, and **removing minor scratches** and **oxide layers**.

Technical data:

Dimensions (mm)	Material	Packaging unit	Grit (K)	Colour (fleece)	Grit (fleece)	Article number
9 x 533	SC nylon fleece with reinforcing fabric	10	180	red	medium	49011s
			280	blue	fine	49012s



Suitable for

STEEL · STAINLESS STEEL

Trizact™ Belt



Ideal for removing scratches and pre-polishing for mirror-finish polishing

New type of **abrasive cloth** with **pyramid-shaped grit structure**. **Saves** on several **operating steps** and has high material removal with very **fine results while removing scratches and spot welds**. Ideal pre-polishing for subsequent mirror-finish polishing. Leaves **very minor surface roughness**.

Technical data:

Dimensions (mm)	Packaging unit	Grit (Trizact™)	Grit (K)	Material removal (like approx. K)	Article number
9 x 533	10	A100	220	36	49034
		A65	280	40	49035
		A45	400	50	49036
		A30	600	60	49037
		A16	1200	80	49038
		A06	2000	120	49039



Suitable for

ALUMINIUM · NON-FERROUS METALS · HARD PLASTICS

Felt Belt



Closed Merino felt belts for tasks from **main polishing to mirror finishing of stainless steel and non-ferrous metals**.

Suitable for hard plastics as well. **Please Note:** Do not use different pastes or creams on the same felt belt.

Technical data:

Dimensions (mm)	Material thickness (mm)	Material	Packaging unit	Article number
9 x 533	5	Merino felt	10	49015



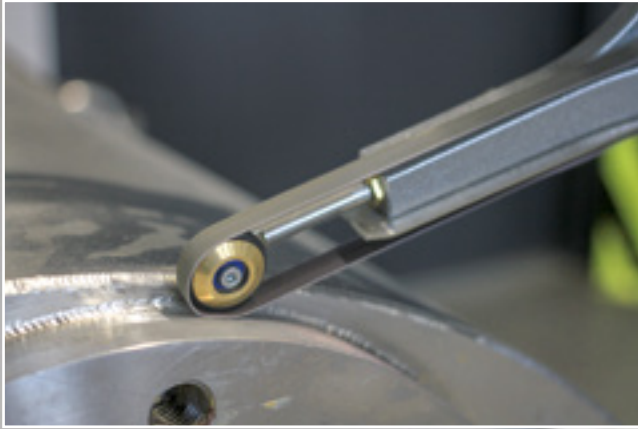

Adjusts perfectly to interior fillet welds.



Suitable for

ALL METALS

NEW FORMULATION

BRIGHTEX® High-performance Polishing Pastes

The fastest way to a mirror finish

For the first time, the **pre-polishing and main polishing steps can be completed with just one paste (BRIGHTEX® Berry)**! This has been made possible by a completely new formulation. For instance, stainless steel can be polished to a mirror finish in only a few moments. This saves **several working steps**. The yellow **BRIGHTEX® Sun** paste creates an **even brighter high gloss shine** – almost as if it's **chrome plated**. Both pastes can be used on SuperPolish discs and belts and on felt discs, belts, and sleeves. The pastes are applied to the polishing disc, belt, or sleeve while it is running at a low speed so that it is completely covered. This process can be repeated several times. The pastes can also be used for the new BRIGHTEX® polishing system (pre-impregnated polishing discs, belts, and sleeves) to “top up” the polishing fleeces as required.



FEATURES

Step 1: BRIGHTEX® Berry (pre-polishing):

- For applying a rapid high-gloss polish to all metals.
- Pre-polish and main polish in one – save on additional working steps.

Step 2: BRIGHTEX® Sun (main polish):

- A mirror finish that's almost like chrome plating – perfect finish.
- For a final high-gloss shine on polished metals.
- For removing any residual clouding and smears from all metals.
- **Please Note:**
After changing pastes, always remove the polish residue from the workpiece!

- For reconditioning high-gloss surfaces which have been polished mechanically.
- For use with felt, cotton, fleece discs, wheels, sleeves, belts, etc.
- Ideal for use with polishing machines and hand-held polishing tools (POLY-PTX®).
- For the best results, use Eisenblätter care and cleaning products to remove polish residues (BRIGHTEX® Softclean Powder, Power Cleaner).
- Completely new high-tech paste formulation for metals.

Technical data:

Paste	Contents (g)	Application	Packaging unit	Article number
BRIGHTEX® Berry pre- and main polish (pink)	about 1,100	High-gloss polishing	1	40025
BRIGHTEX® Berry mini paste (pink)	about 140	High-gloss polishing	1	40025m
BRIGHTEX® Sun post-polishing paste (yellow)	about 1,300	Mirror-finish polishing	1	40026
BRIGHTEX® Sun mini paste (yellow)	about 140	Mirror-finish polishing	1	40026m

Suitable for

ALL METALS

BRIGHTEX® Softclean Powder

A **new**, much improved **cleaning powder** removes all cream and paste residue after every polish, giving all metals a polished, completely scratch-free shine. Simply apply a little using the shaker, as you would powdered sugar, and wipe it off with a **clean microfibre cloth** without applying any pressure. The powder consists of **ultra-fine micro-particles** with a large surface area for the **best possible absorbency**.



Technical data:

Packaging	Contents (g)	Packaging unit	Article number
Resealable bag	about 1,000	1	40028
Aluminium shaker	about 200	1	40029

Suitable for

ALL MATERIALS

BRIGHTEX® Microfibre Cloths



Much improved, **ultra-soft microfibre cloth**, free of seams for completely **scratch-free cleaning** of **stainless steel surfaces** and other **decorative metals**. Particularly soft and absorbent. Can be washed repeatedly.

Technical data:

Dimensions (mm)	Quality	Packaging unit	Article number
400 x 400	360 g/m ²	5	40031



NEW



Suitable for

ALL METALS

Power Cleaner

Universal cleaner in its most environmentally-friendly form

Clean and preserve – especially for the removal of grease-based polish residue (BRIGHTEX® pastes).

YOU CAN FIND MORE DETAILS ON PAGE 276.

Technical data:

Packaging	Contents	Packaging unit	Article number
Spray bottle	50 ml	1	40057
	500 ml	1	40055
Can (including spray bottle)	5 litres	1	40056

Suitable for

ALL METALS

Polishing Pastes (Classic)

Mirror-finish polishing for all metals (including aluminium).

White for pre-polishing, blue for final polish.

Technical data:

Paste	Contents (g)	Pkg. unit	Article number
Pre-polishing paste (white)	about 650	1	40013
Polishing paste (blue)	about 650	1	40014
White and blue mini paste	approx. 120 (60 each)	1	40009



Suitable for

ALL METALS

Pink Polishing Cream

For final polishing, with Classic polishing pastes, for example, it produces a flawless mirror finish on all metals when applied with SuperPolish, felt, and polishing rings. Brings a quick shine – also suitable for manual application with polishing cloths. Ideal for moulded parts as well.

Technical data:

Packaging	Contents	Packaging unit	Article number
Can	about 1,000 g	1	40015
Mini-tube	approx. 60 ml	1	40015t



A man with a beard and safety glasses on his head, wearing a white tank top, is holding a rectangular metal block. He is standing in a factory or industrial setting, next to a metalworking machine. The machine has a red top and a yellow emergency stop button. The background shows a staircase and industrial structures.

**If you can't
stand sharp
burrs!**

DEBURRING AND BEVELLING

POWER TOOLS	258	STATIONARY MACHINES	262
ROLEI EF 115	258	ROLEI EF 165	262
ROLEI EF 115 accessories	260	ROLEI EF 165 accessories	264
ROLEI deburring system	261	ROLEI special flap discs	265
		ROLEI PEF 500	266
		ROLEI PEF 500 accessories	268
		ROLEI special flap discs	269
		ROLEI BE 5 sheet metal deburring machine	270
		ROLEI BE 5 accessories	272
		ROLEI BE 5 flap wheel	272
		EISENBLÄTTER DEMO CENTER	273

ROLEI EF 115

Manual deburring and bevelling tool



The **practical deburring tool** for cumbersome, large, heavy components such as machine tables, frame constructions, and large metal panels. **Easy to handle** with good edge control. The ROLEI EF 115 is also ideal for weld chamfering. Fixed bevel angle of 45°; **bevel width can be infinitely adjusted** from 0 to 10 mm. Now with a rubberised handle for excellent control! The handy ROLEI EF 115 can easily deburr and bevel large, heavy components. Precision edge guidance guarantees chamfers at 45° **with no counter-burr**.

FEATURES

- **Extremely powerful motor for continuous use.**
- **Particularly sturdy, wear-resistant, solid cast iron parts.**
- **Quick adjustment of bevel width.**
- **Balanced handle** reduces strain on the user.
- Quick, **uncomplicated disc change.**
- Various tool grit grades (coarse to fine) can be delivered.
- **Ideal for chamfering welds.** Also suitable for wide weld bevels.



Technical data ROLEI EF 115 machine

Plug type	Cable type	Mains connection (V ~ Hz)	Power (W)	Speed (rpm)	Bevel angle	Bevel width (mm)	Weight (kg)	Pkg. unit	Article number
EU (C+F)	QUICK-LOCK	220-240 ~ 50-60	1,750	2,000-7,600	45°	0-10	4.1	1	30115
UK (G)	Permanent connection	110 ~ 50-60	1,600	2,000-7,600	45°	0-10	4.1	1	30116

Delivery scope: 1 ROLEI EF 115 machine, 1 case, 1 QUICK-LOCK cable (4 m), 1 flap disc

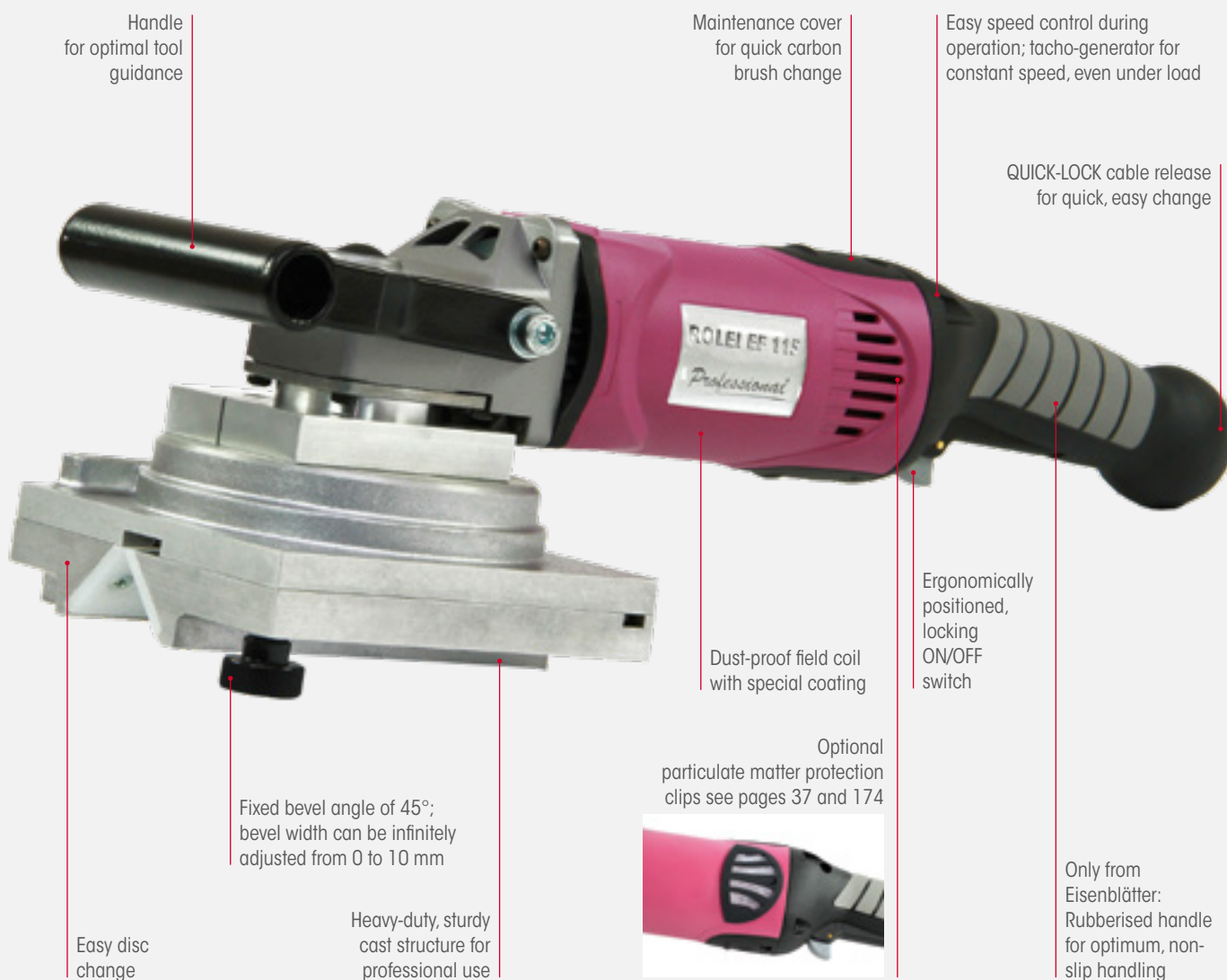

POWER TOOLS

QUICK-LOCK Cable

Suitable for VARILEX® WSF 900, 1600 & 1800, POLY-PTX® 300, 500 & 800, ROLEI EF 115, PIPE MAX, PIPE SNIPER, and GLADIUS® 1800.

Technical data:

Version	Cable length (m)	Voltage (V)	Packaging unit	Article number
EU (C+F)	4	220-240	1	52004-3
EU (C+F)	10	220-240	1	52005-3
CH (J)	4	220-240	1	52004-3s
AU	4	220-240	1	52004-3a
UK (G)	4	110	1	52004-3e
US (B)	4	120	1	52004-3u
Plug adapter – EU to UK	4		1	52004d



Suitable for

ROLEI EF 115

Plastic Replacement Guide Rails

Replacement guide rails for fitting to the ROLEI EF 115 (1 pack = 1 pair)

Technical data:

Packaging unit	Article number
1	30117



Suitable for

VARILEX® WSF 1800 · POLY-PTX® 800 · ROLEI EF 115

Particulate Matter Protection Clips

Greatly reduces the risk of an electronic short circuit due to metal dust

The new dust protection clips prevent dust and contamination particles from entering the machine's interior and thus increase its service life.

YOU CAN FIND MORE DETAILS ON PAGE 37 AND 174.



Suitable for

STEEL · STAINLESS STEEL · CAST IRON · NON-FERROUS METALS · ALUMINIUM

ZIRCOTEX® Nylon Flat

Hard compressed zirconium flap disc.

Replacement disc for ROLEI EF 115.

YOU CAN FIND MORE DETAILS ON PAGE 70.

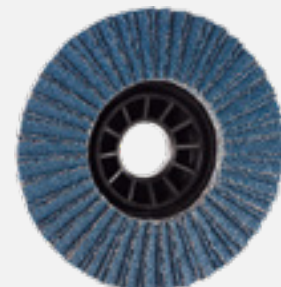

Basic principle of the ROLEI deburring system

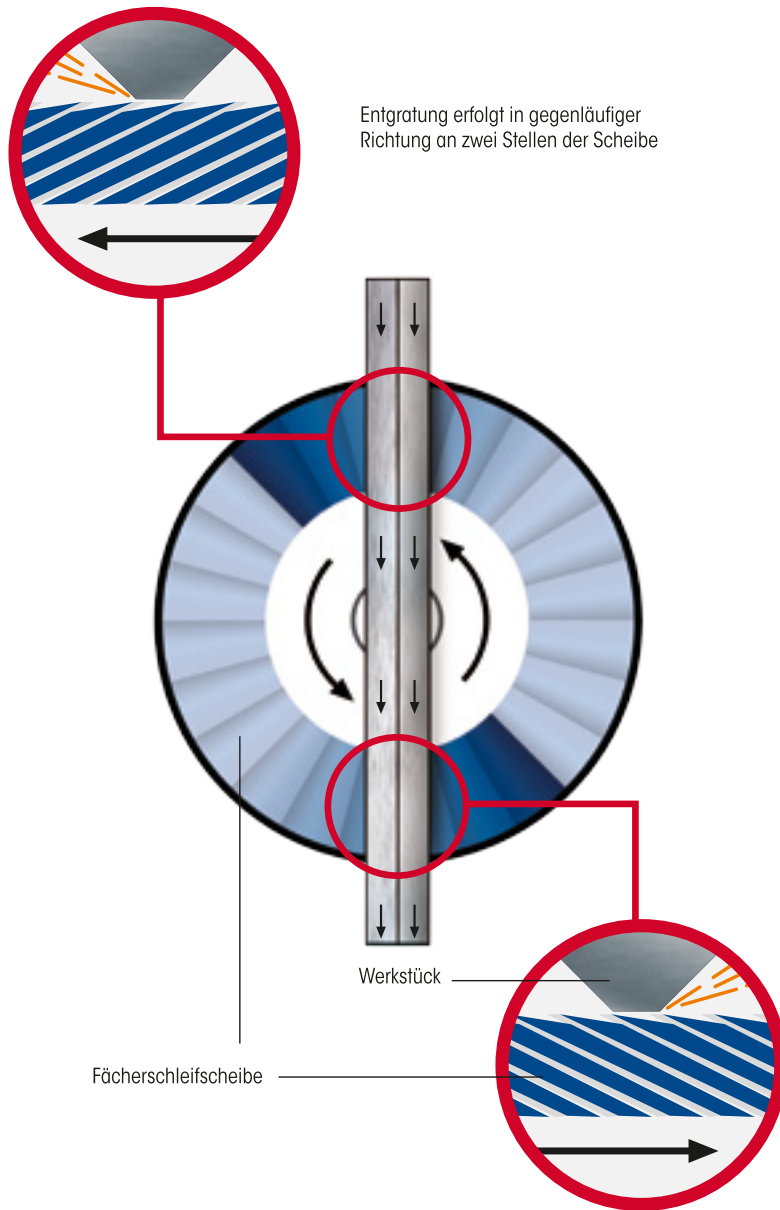

Grinding instead of milling saves a considerable amount of time and tool costs. Perfect cross-grinding in one operation guarantees edges with no counter-burr or chatter marks. All metals, including stainless steel, can be worked with this flexible deburring tool.

ROLEI deburring and bevelling machines work with flat flap discs (the BE 5 sheet metal deburring machine with flap wheels). The grinding tools are "self-sharpening" and have an extremely long service life.

The machines are easy and safe to operate and the grinding tools can be changed quickly and easily.

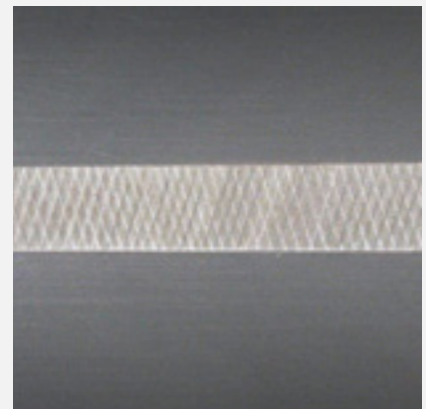
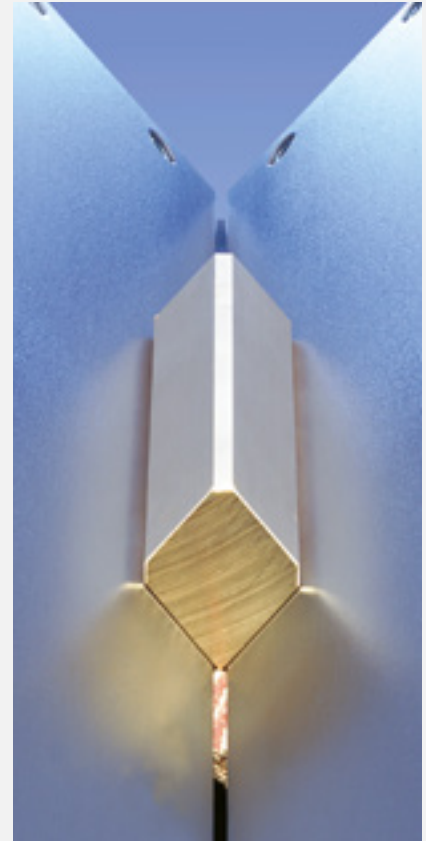

IMPROVED

ROLEI EF 165

for bevels of 45°

Bevelling and deburring machine with fixed bevel angle and infinitely adjustable bevel width for all metals from stainless steel to aluminium. A hand wheel provides infinite, precise bevel width setting. Eisenblätter was awarded the Bavarian State Prize for its deburring machine at the Internationale Handwerksmesse show in Munich.

FEATURES

- **Simple, safe operation.**
- **Low-cost replacement grinding disc** with an extremely long service life (one disc can often be used for months).
- **Bevelling of workpieces of 2.5 mm or more in thickness.**
- **Suction flange for industrial extractors supplied as standard (internal diameter 35 mm).**
- **Winner of the Bavarian State Prize.**

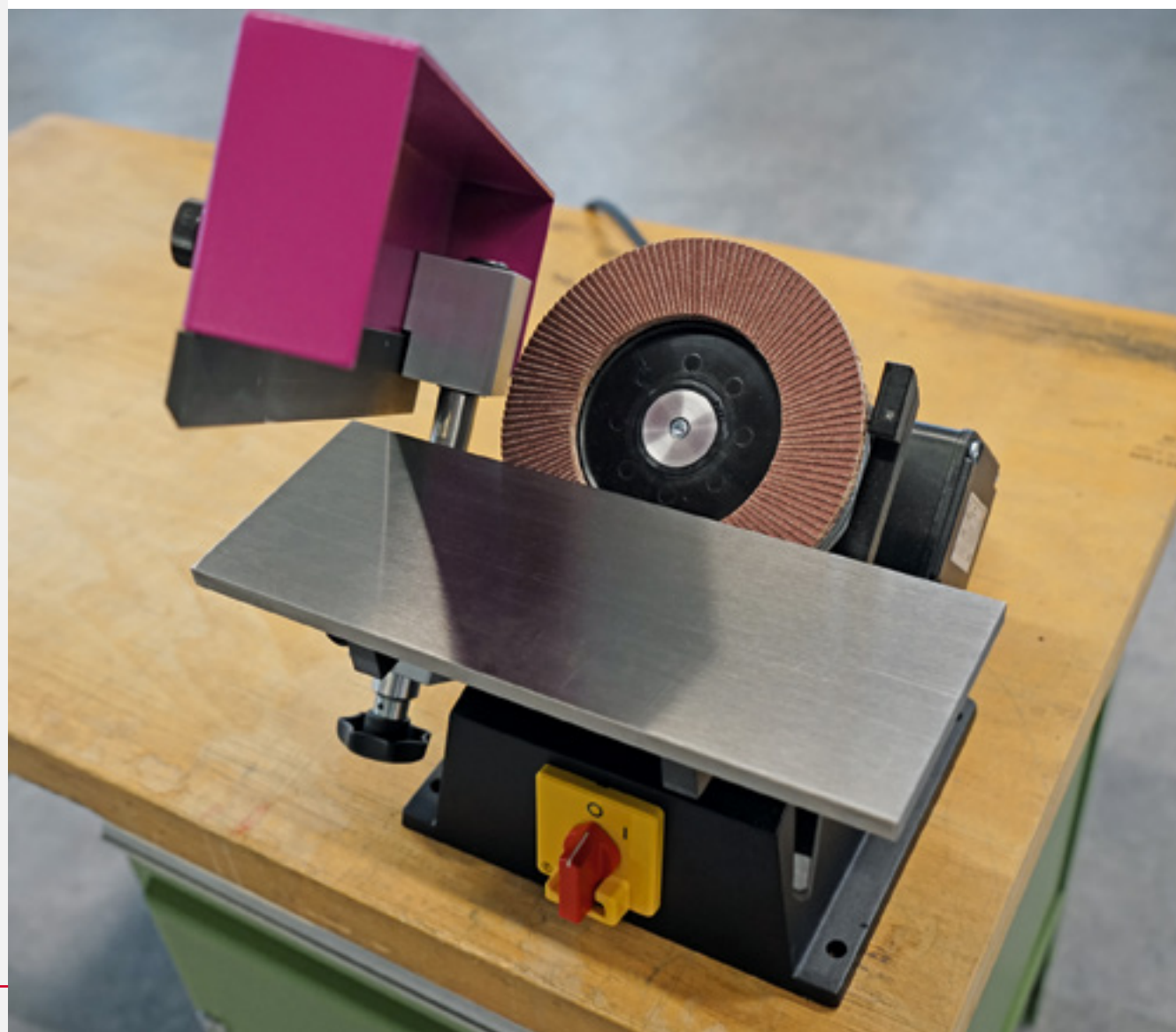

Technical data ROLEI EF 165 machine

Dimensions (mm)	Plug type	Mains connection (V ~ Hz)	Speed (rpm)	Bevel angle	Bevel width (mm)	Weight (kg)	Pkg. unit	Article number
360 x 320 x 300	3-phase	380 ~ 50	2,800	45°	0-10	18	1	30100
360 x 320 x 300	EU (C+F)	220-240 ~ 50-60	2,800	45°	0-10	18	1	30101

Delivery scope: ROLEI EF 165 machine, 1 ROLEI special flap disc

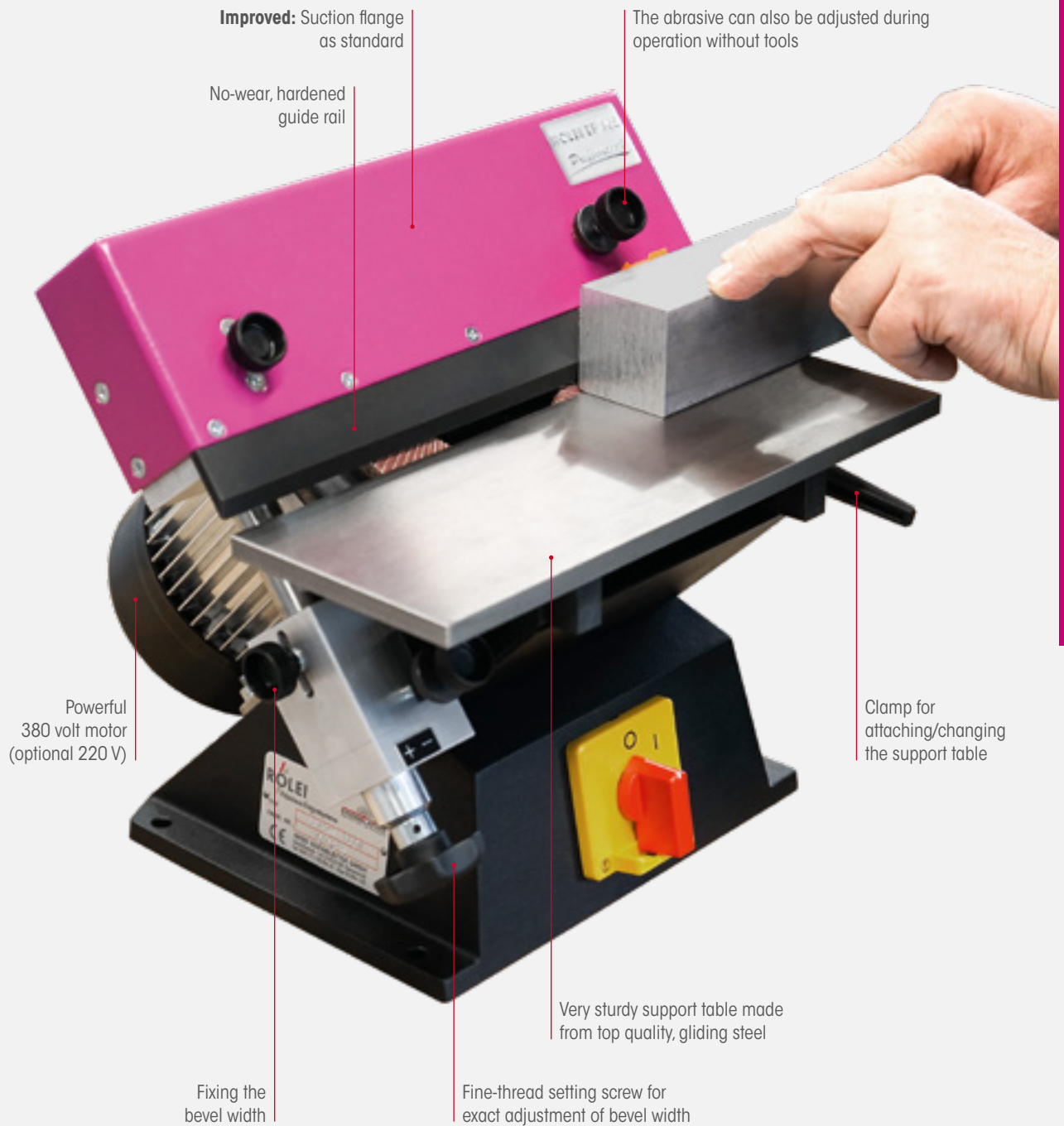

STATIONARY MACHINES

Suitable for

ROLEI EF 165

Extended Support Table

Made from gliding steel (1.2842).

Technical data:

Dimensions (mm)	Packaging unit	Article number
120 x 700	1	30110
Other dimensions available on request.		



Suitable for

ROLEI EF 165

ROLEI EF 165 Machine Stand

Sturdy steel machine stand including fixing bolts with black powder coating for working comfortably in a standing position.

Technical data:

Dimensions (L x W x H) (mm)	Weight (kg)	Packaging unit	Article number
245 x 215 x 660	about 20	1	30120



Suitable for

STEEL · STAINLESS STEEL · NON-FERROUS METALS

ROLEI Special Flap Disc

The flap disc with especially hard compression for deburring machines. Self-sharpening with an extremely long service life!



Technical data:

Dimensions (mm)	Suitable for	Packaging unit	Grit (K)	Article number
170 x 22	ROLEI EF 165, ROLEI PEF 500	1	50	36050
			60	36060
			80	36080
			120	36120

CHOOSE THE RIGHT GRIT/DISC:

Stainless steel, steel 50 grit/60 grit
Aluminium, copper, brass . . 80 grit/120 grit
Hard plastic 120 grit



Suitable for

ALL METALS

ROLEI HellFire® Special Flap Disc

Ceramic hybrid disc with hard compression for **particularly high rate of metal removal** in one operation. Suitable for larger bevel widths due to high disc aggressivity. **Coarse to medium application; grinds all metals** from steel to stainless steel to titanium to non-ferrous metals.



Technical data:

Dimensions (mm)	Suitable for	Packaging unit	Grit (K)	Article number
170 x 22	ROLEI EF 165, ROLEI PEF 500	1	Multigrain 40/60	36046

CHOOSE THE RIGHT GRIT/DISC:

All metals Multigrain 40/60



ROLEI PEF 500

for facets of 30° – 45° – 60°

Very **sturdy**, highly **precise deburring and bevelling tool** for all metals from stainless steel to aluminium. **Bevel angle** can be set and bevel width is **infinitely adjustable** (precision setting by means of knurled division). The bevel width can be adjusted precisely using a hand wheel. Parts are bevelled in **perfect cross-hatched grinding** with absolutely no **counter-burr**. Disc wear is adjusted with a hand wheel via a threaded spindle. The bevel angle is adjusted using a motorised system on the angled guide.



FEATURES

- **Simple, safe operation.**
- **Low-cost replacement grinding disc** with an extremely long service life (one disc can often be used for months).
- **Suction flange for industrial extractors** supplied as standard (internal diameter 35 mm).
- Bevelling of workpieces of 2.5 mm or more in thickness.

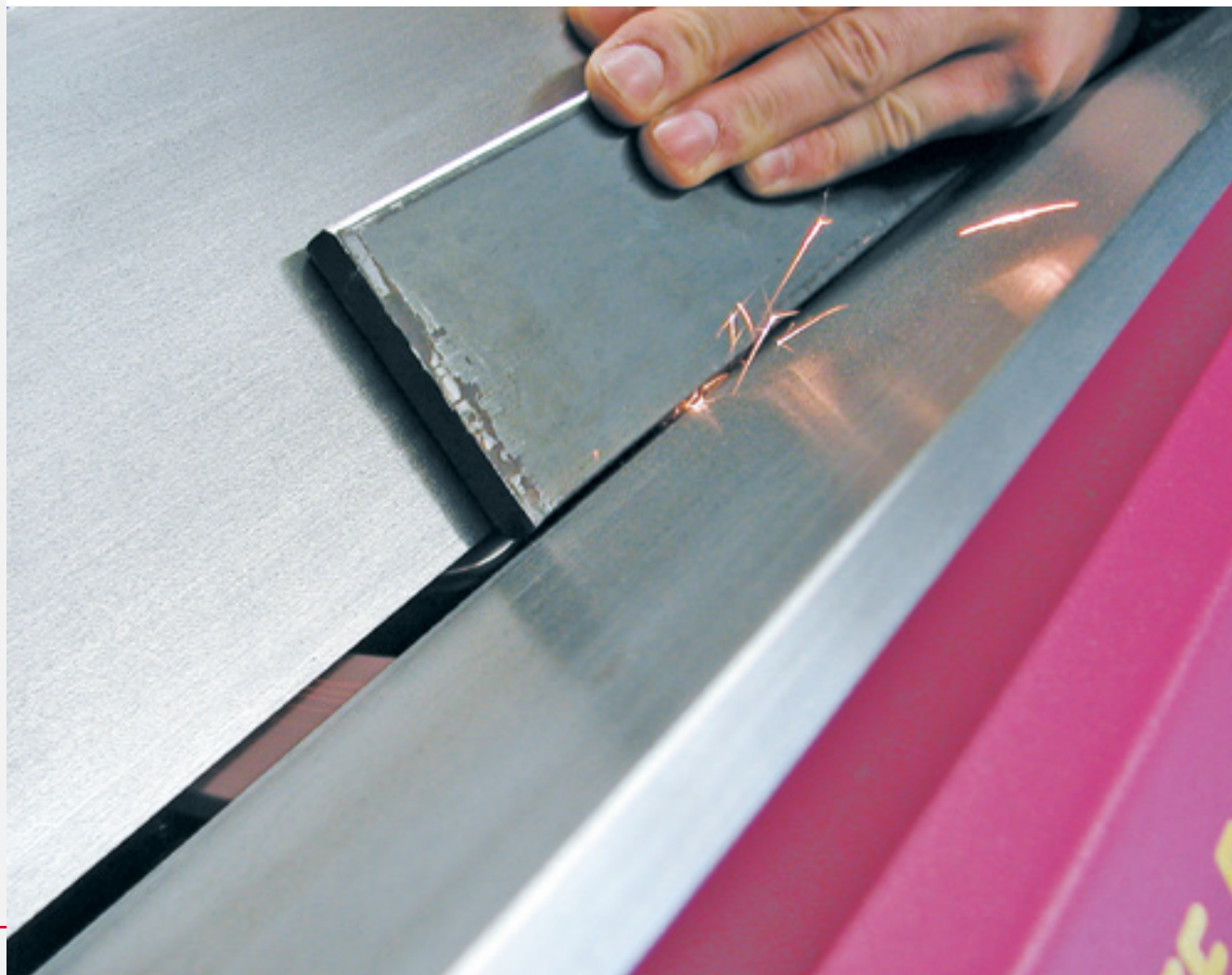

Technical data ROLEI PEF 500 machine

Dimensions (mm)	Plug type	Mains connection (V ~ Hz)	Speed (rpm)	Bevel angle	Bevel width (mm)	Weight (kg)	Pkg. unit	Article number
500 x 350 x 350	3-phase	380 ~ 50	2,800	30° – 45° – 60°	0-10	45	1	30200
500 x 350 x 350	EU (C+F)	220-240 ~ 50-60	2,800	30° – 45° – 60°	0-10	45	1	30201

Delivery scope: 1 ROLEI PEF 500 machine, 1 ROLEI special flap disc

Very sturdy 700-mm guide rail of high-quality, gliding steel specially hardened against corrosion including fastening bores for the thin sheet metal accessory package

Hard compression flat special flap disc with an extremely long service life

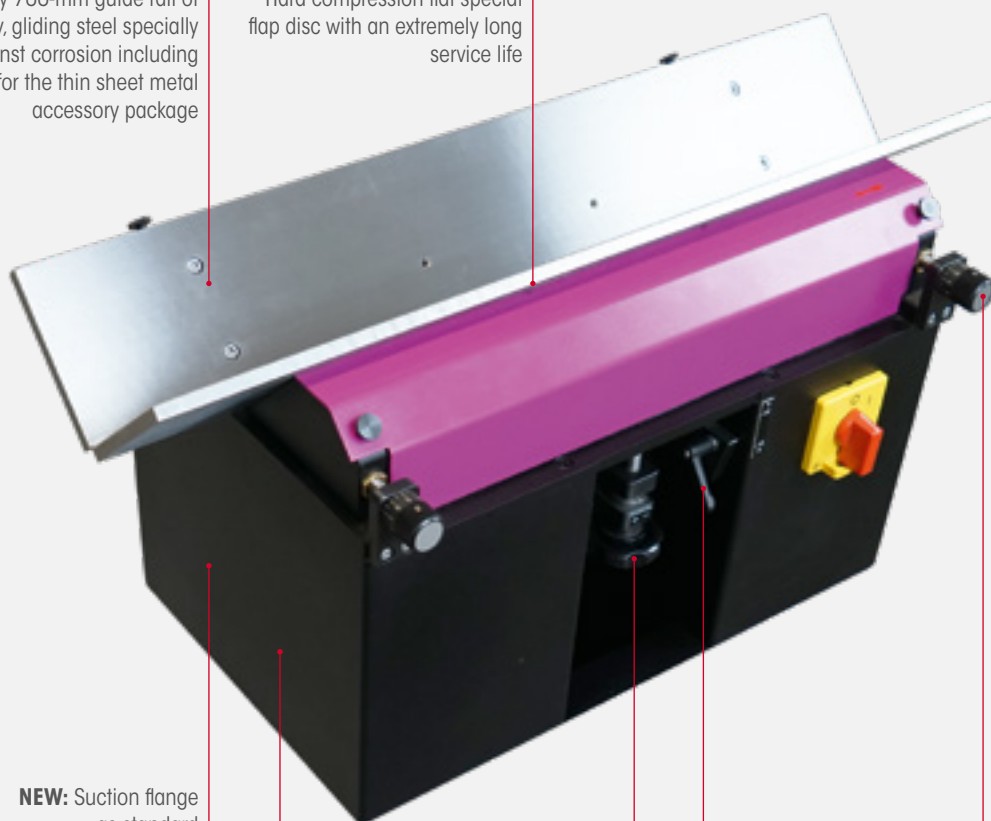

NEW: Suction flange as standard

Powerful 380 volt motor (optional 220 V)

New locking screw for setting the height of the deburring tool precisely and adjusting the abrasive during operation without tools



Adjustable bevel angle (30° – 45° – 60°)

Fine-thread setting screw for exact adjustment of bevel width

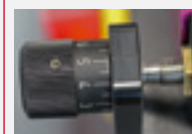

Now bevel and deburr thin sheets of metal and long square bars with an optional thin sheet metal accessory package (see page 268).

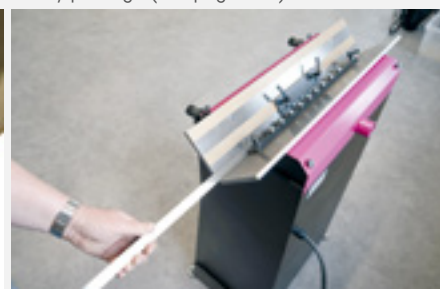
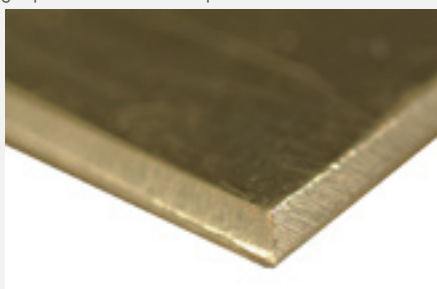

Suitable for

ROLEI PEF 500

Thin Sheet Metal Accessory Package

For bevelling thin sheet metal (name and company badges) from thicknesses of approx. 2.5 mm and as a guidance aid for deburring long square bar material.



Technical data:

Description	Suitable for	Packaging unit	Article number
Thin sheet metal accessory package	ROLEI PEF 500	1	30211

Set contents:

- 1 roller bar with 9 ball bearings and fixing bolts
- 1 guide rail with knurled screws
- 1 angular hand guide of gliding plastic

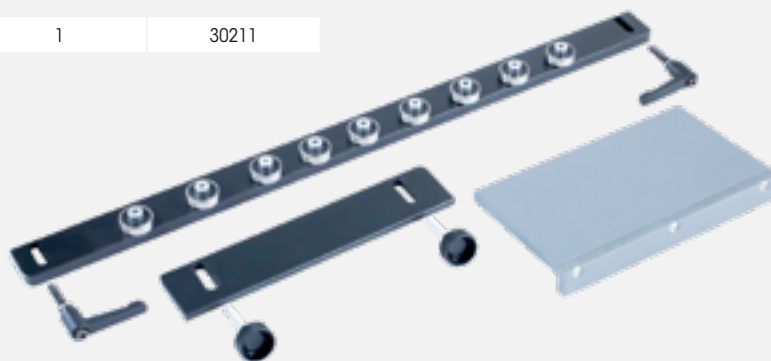

ACCESSORIES

Suitable for

ROLEI PEF 500

ROLEI PEF 500 Machine Stand

Sturdy steel machine stand including fixing bolts with black powder coating for working comfortably in a standing position.



Technical data:

Dimensions (L x W x H) (mm)	Weight (kg)	Packaging unit	Article number
505 x 305 x 660	about 20	1	30220



ACCESSORIES

Suitable for

STEEL · STAINLESS STEEL · NON-FERROUS METALS

ROLEI Special Flap Disc



The flap disc with especially hard compression for deburring machines. Self-sharpening with an extremely long service life!

Technical data:

Dimensions (mm)	Suitable for	Packaging unit	Grit (K)	Article number
170 x 22	ROLEI EF 165, ROLEI PEF 500	1	50	36050
			60	36060
			80	36080
			120	36120

CHOOSE THE RIGHT GRIT/DISC:

Stainless steel, steel 50 grit/60 grit
 Aluminium, copper, brass . . 80 grit/120 grit
 Hard plastic 120 grit



Suitable for

ALL METALS

ROLEI HellFire® Special Flap Disc



Ceramic hybrid disc with hard compression for **particularly high rate of metal removal** in one operation. Suitable for larger bevel widths due to high disc aggressivity. **Coarse to medium application; grinds all metals** from steel to stainless steel to titanium to non-ferrous metals.

Technical data:

Dimensions (mm)	Suitable for	Packaging unit	Grit (K)	Article number
170 x 22	ROLEI EF 165, ROLEI PEF 500	1	Multigrain 40/60	36046

CHOOSE THE RIGHT GRIT/DISC:

All metals Multigrain 40/60



ROLEI BE 5 Sheet Metal Deburring Machine

The ideal workbench or free-standing tool for quick deburring of all metals (including stainless steel) on both sides up to approx. 5 mm of sheet thickness in one operation.



FEATURES

- **Simple, safe operation** without prior familiarity.
- **2 speeds** available (600 and 1,200 rpm).
- **Powerful 380-volt three-phase motor for continuous operation.**
- **Sturdy aluminium transmission** with spindle mounts for replacement tools.
- **1 set** (2 units) of flap wheels **deburrs about 2000 m of sheet stainless steel.**
- Replacement tools are easy to change.
- Suction **flange for industrial extractors supplied as standard** (internal Ø 35 mm).
- Wear-free, hardened guide rail (infinitely adjustable).

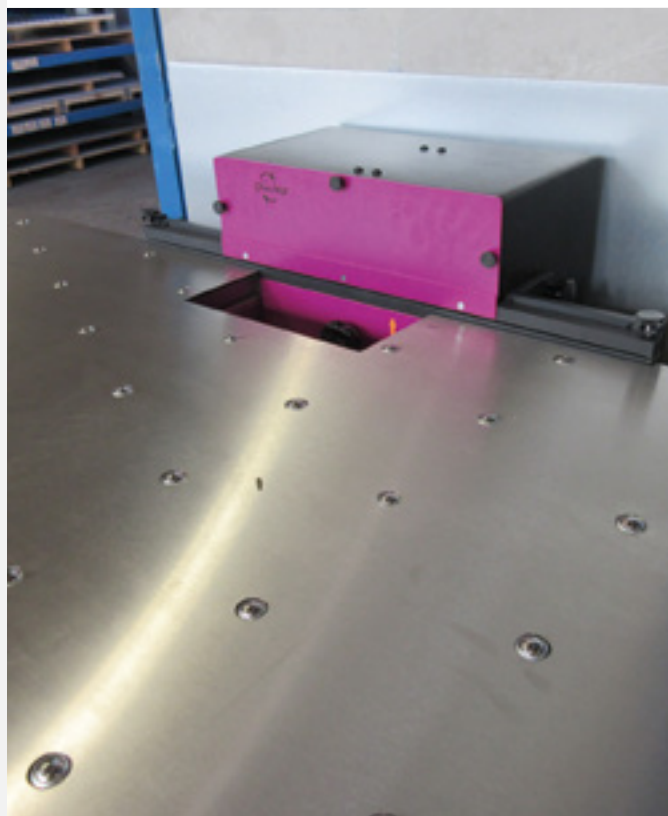

ROLEI BE 5 deburring tool can also be used on its side with a roller table for larger sections of sheet metal, for instance.

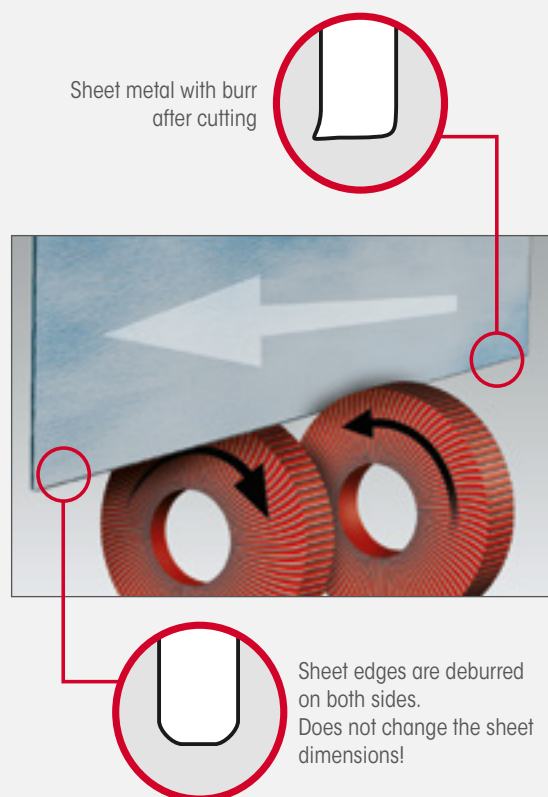

Technical data ROLEI BE 5 machine

Dimensions (mm)	Plug type	Mains connection (V ~ Hz)	Power (W)	Speed (rpm)	Sheet metal thickness (working mm)	Weight (kg)	Pkg. unit	Article number
700 x 325 x 200	3-phase	380 ~ 50	750	Setting 1: Fine deburring 600 Setting 2: Standard deburring 1,200	0-5	29	1	30310

Delivery scope: 1 ROLEI BE 5 machine, 2 original ROLEI BE 5, 60 grit flap wheels (standard)

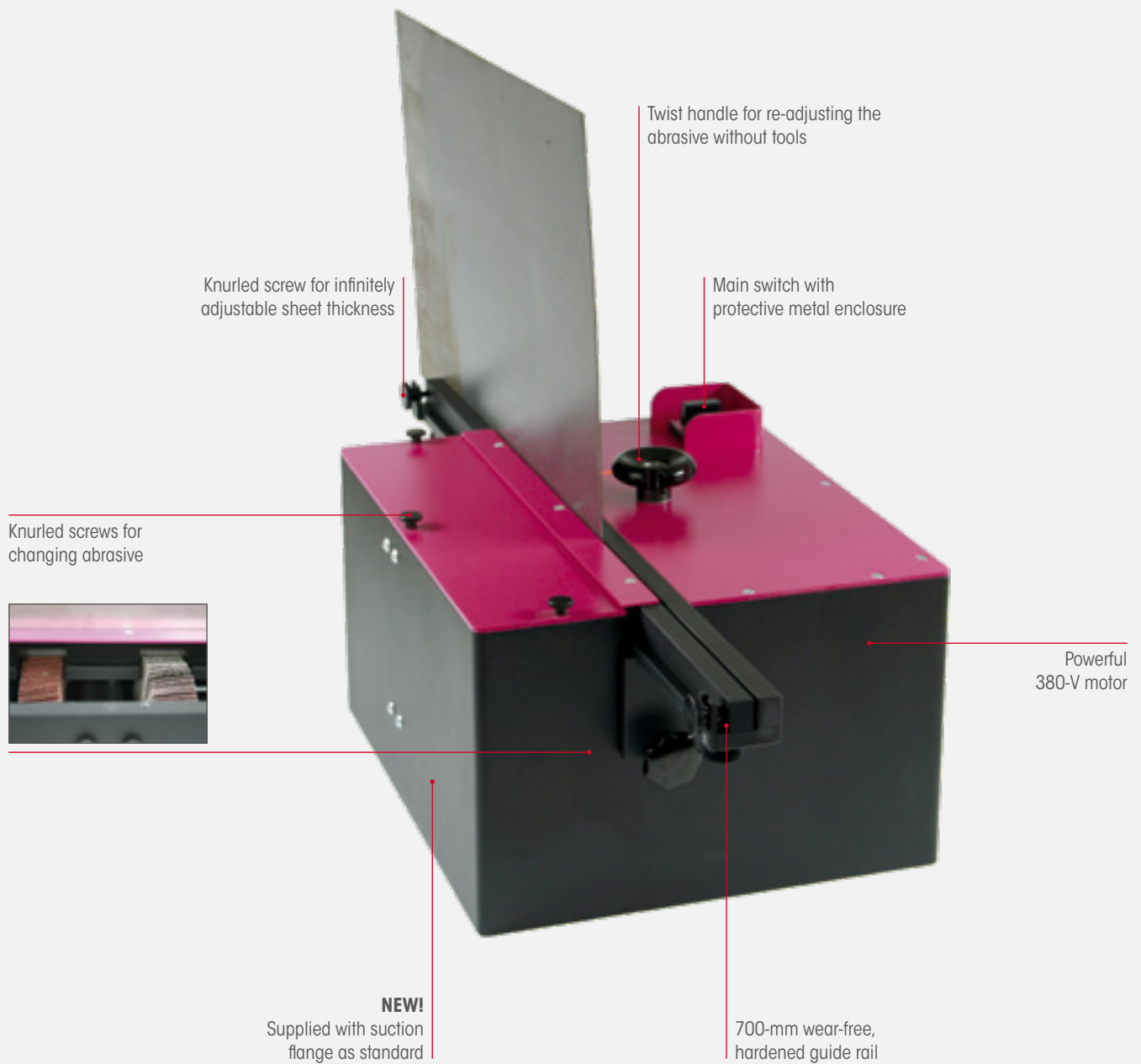

STATIONARY MACHINES

Suitable for

ROLEI BE 5

ROLEI BE 5 Machine Stand

Sturdy steel machine stand with black powder coating for working comfortably in a standing position.

Technical data:

Dimensions (L x W x H) (mm)	Weight (kg)	Packaging unit	Article number
385 x 325 x 660	about 20	1	30320



Suitable for

ROLEI EF 165 · ROLEI PEF 500 · ROLEI BE 5

Teflon Strips (self-adhesive)

For the guide rail. To protect against scratches on the workpiece/sheets!

Technical data:

Dimensions (mm)	Material	Packaging unit	Article number
20 x 700	Teflon	10	30341



Suitable for

ALL METALS

ROLEI BE 5 Flap Wheel



Replacement grinding flap wheels, 100% cotton quality, for great deburring. Cotton design ensures that the wheel can be used for a particularly wide range of applications and ideal employment of grinding tools.

Tip: To prevent damage to the ROLEI BE 5 transmission system, use only original ROLEI flap wheels with 100% cotton fabric.

Technical data:

Dimensions (mm)	Packaging unit	Grit (K)	Article number
165 x 30	2	40	37040
		60	37060
		80	37080
		120	37120



EISENBLÄTTER is coming to you! Make an appointment now:

EISENBLÄTTER Demo Center

Phone (+49) 2633 2000 982 · demo@eisenblaetter.de

Koblenzer Str. 29a · 56656 Brohl-Lützing, Germany



**When
stainless steel
is your
business card!**

CHEMICALS AND CARE PRODUCTS

CLEANING 276

- NEW** Power Cleaner 276
- BRILLIANCE CLEAN 277

PROTECTION 278

- INOX PROTECT (dry, hard wax) 278

PRESERVE 279

- POLY SEAL (oil film) 279

GRINDING ADDITIVES 280

- KANGAROO ALU-FIX oil 280

TEST PACKAGES 281

- NEW** Indoor test package 281
- NEW** Outdoor test package 281



NEW

Suitable for

ALL METALS

Power Cleaner

Universal cleaner in its most environmentally-friendly form

Clean and preserve – especially for the removal of grease-based Polish residue (BRIGHTEX®).

FEATURES

- **Water-based** for removing mineral soiling.
- Removes oil, grease and polish/paste residue from metal surfaces.
- Removes cement and adhesive residue and lime film.
- **Multi-functional use.**
- **No labels according to the CLP and REACH Regulation, free of VOC.**
- **Solvent-free application.**

Technical data:

Packaging	Contents	Packaging unit	Article number
Spray bottle	50 ml	1	40057
	500 ml	1	40055
Can (including spray bottle)	5 litres	1	40056

Larger sizes are available on request.

Quick, simple removal of paste and polish residues, stubborn soiling, and adhesive and oil residue.



Suitable for

ALL METALS · PAINTED SURFACES · HARD PLASTICS · WOOD · GLASS · ACRYLIC

BRILLIANCE CLEAN

Streak-free cleaning of ground and unground metal surfaces

Quickly removes **all kinds of minor contaminants** from all metals, including stainless steel, aluminium, copper, and brass, but also glass, wood, hard plastics, and much more. **Evaporates quickly**, leaving all **surfaces free of streaks and residue**. Particularly suited to stainless steel surfaces. Can also be used for any other cleaning jobs, even around the house. It is the quickest and most effective solution. BRILLIANCE CLEAN is **completely environmentally friendly and non-toxic**. Try it once and you won't want to be without this time-saving cleaning aid ever again! No more water cleaning!



Technical data:

Packaging	Contents	Packaging unit	Article number
Spray bottle	50 ml	1	40050m
	500 ml	1	40050
Can (including spray bottle)	5 litres	1	40051

Larger sizes are available on request.

Quick, streak-free cleaning for a variety of surfaces.



Suitable for

ALL INDOOR METALS

INOX PROTECT (dry, hard wax)

The smartest way to protect and optically upgrade stainless steel – an absolute necessity for all stainless steel surfaces

Quickly cleans and provides long-term protection from fingerprints and stains for decorative surfaces, **giving them a transparent, protective layer of hard wax.** Ideal for visible stainless steel surfaces of all kinds, kitchen panelling, ground stainless steel lift walls, railings, rods, pipes, stainless steel tables, and much more. Can also be used for all other metals. Spray it onto parts and distribute it by rubbing with a microfibre cloth; after a few seconds, polish with a second dry microfibre cloth. **All parts will look completely new** and can simply be re-polished dry at any time until the agent is re-applied.



Technical data:

Packaging	Contents	Packaging unit	Article number
Spray bottle	50 ml	1	40040m
	500 ml	1	40040
Can (including spray bottle)	5 litres	1	40041

Larger sizes are available on request.

Quick cleaning and sealing.



Suitable for

STAINLESS STEEL · NON-FERROUS METALS (INDOORS AND OUTDOORS)

POLY SEAL (oil film)

Cleaning and preserving

Ideal for **decorative outdoor stainless steel surfaces** such as stainless steel doors, facades, railings, fountains, figures, artworks, large kitchens, and the hotel industry. Practical spray bottle for ideal dosing and effective application (can be refilled).

For cleaning and preserving ground and polished surfaces. Finger smudges, water spots, and shadows remain invisible for a long time. For outdoors and the food sector (**food-grade**).



Technical data:

Packaging	Contents	Packaging unit	Article number
Spray bottle	50 ml	1	40011m
	500 ml	1	40011
Can (including spray bottle)	5 litres	1	40012

Larger sizes are available on request.

Protect from water spots in the outdoor area for a long time.



Suitable for

ALUMINIUM

KANGAROO ALU-FIX Oil



This unique **special oil for machining aluminium** prevents flap discs from **smearing** and increases service life and **performance by up to 300%**. Simply spray the agent onto the workpiece before grinding and grind as normal!

Technical data:

Packaging	Contents	Packaging unit	Article number
Spray bottle	50ml	1	40010m
	500 ml	1	40010
Can (including spray bottle)	5 litres	1	40010k

Larger sizes are available on request.



Indoor Care Test package

NEW

Pore-deep cleaning and long-term protection for indoor metals

The environmentally friendly POWER CLEANER removes even stubborn contamination such as cement and adhesive residue and lime film and, immediately after polishing, polishing paste and cream residue. BRILLIANCE CLEAN removes minor contamination, completely streak-free and without residue. For final surface sealing, INOX PROTECT is applied to form a transparent hard wax layer that provides long-term protection from fingerprints and spots to such metal surfaces as stair railings, lifts, and doorbell panels. Test it yourself!



Technical data:

Application	Packaging	Contents	Packaging unit	Article number
Indoors	Spray bottles	3 x 50 ml	1	40060

Outdoor Care Test Package

NEW

Pore-deep cleaning and long-term protection for indoor and outdoor metals

The environmentally friendly POWER CLEANER removes even stubborn contamination such as cement and adhesive residue and lime film and, immediately after polishing, polishing paste and cream residue. BRILLIANCE CLEAN removes minor contamination, completely streak-free and without residue. To preserve ground and polished surfaces, apply a thin film of POLY SEAL when work is finished. This makes finger smudges, water spots, and shadows remain invisible for a long time. POLY SEAL is also food-grade and is ideal for use in large kitchens and hotels for such items as railings, facades, and artwork. Test it yourself!



Technical data:

Application	Packaging	Contents	Packaging unit	Article number
Outdoors	Spray bottles	3 x 50 ml	1	40061



**The perfect
accessories
for the
perfect tools**

ACCESSORIES

ACCESSORIES	284
Basic carry case for mobile use	284
NEW Professional carrying case	284
NEW Professional carrying case for pipe grinders	285
Stainless steel cover plate	286
Hand fleece	287
NEW WonderGrip® Flex work gloves	287
Clear safety glasses	288
Face mask	288
Hearing protection	288
NEW Ball joint mount	289

Basic Carry Case

for mobile use

Sturdy, heavy-duty plastic design for use on site.



Technical data:

Interior dimensions (L x W x H) (mm)	Exterior dimensions (L x W x H) (mm)	Suitable for	Pkg. unit	Article number
495 x 230 x 205	500 x 250 x 240	POLY-PTX®, VARILEX® WSF 1800, MINI MAX® PRO, PIPE FIX DUO & SMART, ROLEI EF 115	1	40008
400 x 190 x 180	415 x 215 x 200	VARILEX® 1000, tools	1	40008b

Professional Carrying Case

Extremely stable

Extremely stable carrying case (survival case) for ideal protection for your grinding machine and tools.



FEATURES

- **Dustproof and splashproof according to the IP67 standard.**
- For the **temperature range between -30 °C and 90 °C.**
- With **pyramid foam inserts** for especially good machine protection.
- Two stable, **folding handles** for upright or longitudinal carrying.
- With **automatic pressure compensation valve** for air transport.
- Especially high quality – made in the EU.

Technical data:

Interior dimensions (L x W x H) (mm)	Exterior dimensions (L x W x H) (mm)	Suitable for:	Pkg. unit	Article number
520 x 290 x 200	574 x 361 x 225	POLY-PTX® 802 HT, VARILEX® 1802 HT, VARILEX® POLISHER, MINI MAX® PRO	1	50103

Professional Carrying Case

for pipe grinders

Extremely stable carrying case (survival case) for ideal protection for your pipe grinder and tools.

NEW



FEATURES

- **Dustproof and splashproof according to the IP67 standard.**
- For the **temperature range between -30 °C and 90 °C.**
- With **pyramid foam inserts** for especially good machine protection.
- Two stable, **folding handles** for upright or longitudinal carrying.
- With **automatic pressure compensation valve** for air transport.
- Especially high quality – made in the EU.

Technical data:

Interior dimensions (L x W x H) (mm)	Exterior dimensions (L x W x H) (mm)	Suitable for:	Pkg. unit	Article number
800 x 370 x 145	850 x 440 x 158	PIPE MAX, PIPE MAX 802 HT, PIPE MAX MINI HT, PIPE SNIPER HT, GLADIUS®, etc.	1	50104

Suitable for

PERFECT MITRE GRINDING

Stainless Steel Cover Plate

for perfect mitre grinding

Stainless steel cover plate produces precision mitre edges and easy cutting with shears. Clean adhesion for perfect mitre grinding on all materials. Self-adhesive, can be removed without leaving any residue – easy control without rework guaranteed.



Technical data:

Dimensions (mm)	Material thickness (mm)	Material	Packaging unit	Article number
Ø 150 x 2,500	0.1	Stainless steel (1.4301/304)	1	40070



Suitable for

STEEL · STAINLESS STEEL · NON-FERROUS METALS · WOOD · HARD PLASTICS

Hand Fleece (supplied on a roll)



For hard to reach places, such as corners, etc.

Completely free of ferrite (iron). Ideal for stainless steel, wood, steel, non-ferrous metals, and hard plastics. High grit density for extremely long service life and uniform grinding. Supplied on practical 10-m storage rolls.

For a shadow-free industrial finish (matt and satin), removing oxide layers, and blending ground sheet metal by hand and in hard-to-reach places.

Technical data:

Width (mm)	Length (m)	Packaging unit	Grit (K)	Article number
100	10	1	80	60080
			180	60180
			280	60280
			400	60400

WonderGrip® Flex Work Gloves

NEW



The original

New work gloves for sensitivity and an outstanding grip for many applications in dry, wet, and oily environments. The EN388 standard and the good mechanical properties show that the WonderGrip® FLEX is an outstanding all-rounder: outstanding resistance to oil, grease, and hydrocarbons; good resistance to organic solvents; resistant to heat and abrasion.

Technical data:

Size	Packaging unit	Article number
M	5	40105m
L	5	40105l
XL	5	40105xl



Clear Safety Glasses

with adjustable earpieces



Adjustable earpieces with soft, rubberised ends to ensure a perfect fit and wearer comfort. High-quality (plastic) lenses ensure unrestricted, distortion-free vision. The product complies with DIN EN 166:2001. For safe, statutory eye protection during work with machines and any grinding and polishing tools.

Technical data:

Material	Standard	Packaging unit	Article number
Transparent plastic	EN 166:2001	1	40104

Face Mask

with exhalation valve



Filter class FFP1 protects against non-volatile solid and liquid particles. Includes an exhalation valve to prevent heat and moisture from becoming trapped in the face mask. Individually adjustable nose clip for the wearer's comfort. Also ideal for those who wear glasses.

Soft, padded interior fleece. Fabric retaining straps for durability and comfort.

The product complies with EN 149:2001.

For safe, statutory protection of the airways during work with hand-held machines and all grinding and polishing tools.

Technical data:

Standard	Packaging unit	Article number
EN 149:2001	10	40100

Hearing Protection

Made from environmentally friendly polyurethane foam that slowly reverts to its original shape. Soft, skin-friendly foam ear plugs that are extremely comfortable to wear. SNR value 37 dB. The product complies with DIN EN 352-2.

For safe, statutory hearing protection during work with hand-held machines and all grinding and polishing tools.



Technical data:

Standard	Packaging	Packaging unit	Article number
EN 352-2	Resealable box (400 units)	1	40103

Suitable for

ALL DEVICES WITH M8 THREADS

Ball Joint Mount

The robust ball joint mount transforms any mobile hand-held machine into a workshop. Grinding or deburring of small parts, polishing of individual pieces or sharpening blades – all these tasks can be performed with your mobile machine thanks to the ball joint mount.

The rotary handle allows the ball joint to be locked safely and without tools – in any position!

Technical data:



Material	Mounting threads	Packaging unit	Article number
Aluminium, painted	M8	1	38663

Application examples



VARILEX® 1802 HT page 22



POLY-PTX® 802 HT page 158



PIPE MAX 802 HT page 214



MINI MAX® PRO 1000 page 112



GLADIUS® 1802 HT page 222

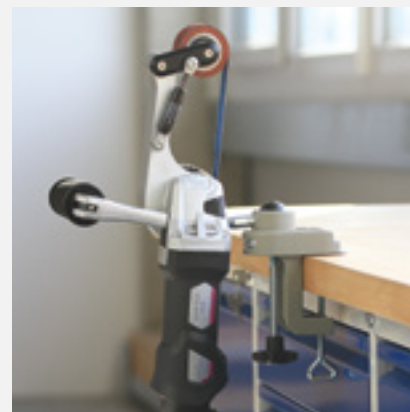

PIPE MAXHT Mini page 232

EISENBLÄTTER

EISENBLÄTTER

EISENBLÄTTER

EISENBLÄTTER

EISENBLÄTTER

EISENBLÄTTER

EISENBLÄTTER

EISENBLÄTTER

EISENBLÄTTER

EISENBLÄTTER

EISENBLÄTTER

EISENBLÄTTER

EISENBLÄTTER

EISENBLÄTTER

EISENBLÄTTER

EISENBLÄTTER

EISENBLÄTTER

EISENBLÄTTER

EISENBLÄTTER

EISENBLÄTTER

EISENBLÄTTER

EISENBLÄTTER

EISENBLÄTTER

EISENBLÄTTER

EISENBLÄTTER

EISENBLÄTTER

EISENBLÄTTER

EISENBLÄTTER

EISENBLÄTTER

EISENBLÄTTER

EISENBLÄTTER

EISENBLÄTTER

EISENBLÄTTER

EISENBLÄTTER

EISENBLÄTTER

EISENBLÄTTER

EISENBLÄTTER

EISENBLÄTTER

EISENBLÄTTER

EISENBLÄTTER

EISENBLÄTTER

EISENBLÄTTER

EISENBLÄTTER

EISENBLÄTTER

EISENBLÄTTER

EISENBLÄTTER

EISENBLÄTTER

EISENBLÄTTER

EISENBLÄTTER

EISENBLÄTTER

EISENBLÄTTER

EISENBLÄTTER

EISENBLÄTTER

EISENBLÄTTER

EISENBLÄTTER

EISENBLÄTTER

EISENBLÄTTER

EISENBLÄTTER

EISENBLÄTTER

BRANDS

EISENBLÄTTER · BLACK MAMBA · BLUE SHARK
BRIGHTEX · COLD STEEL · COOL TOP
FINECUT · GLADIUS · HELLFIRE · MAGNUM
MINI MAX · PLANTEX · PLATINUM · POLY-PTX
RAZORCUT · RAZORFLAP · ROHR MAX
ROHR SNIPER · STEELFIRE · TIGER SHARK
TRIMFIX · TRIMTEX · TWINFLEX · VARILEX
ZIRCOPUR · ZIRCOTEX



ARE REGISTERED TRADEMARKS
OF EISENBLÄTTER

PRESENTED BY:

V20

Gerd Eisenblätter GmbH

Jeschkenstraße 12d

82538 Geretsried

Germany

Phone +49 8171 9082-010

Fax +49 8171 9082-220

info@eisenblaetter.de

www.eisenblaetter.de

www.eisenblatter.com